

CSA-1V

Current Sensor

**Features:**

- Sensitive to a magnetic field parallel to the chip surface
- Very high sensitivity
- Linear output voltage proportional to a magnetic field
- Wide-band: DC to 100kHz
- Very low offset and offset-drift
- Very low noise
- Isolated from current conductor
- Surface mount SOIC-8 package

Applications:

- AC and/or DC current measurement
- Wide-Band Magnetic Field Measurement
- Battery Chargers
- AC-DC Converters
- Motor Control

General Description

The CSA-1V is a single-axis integrated magnetic field sensor based on the Hall effect. The circuit is fabricated using a conventional CMOS technology with an additional ferromagnetic layer. The ferromagnetic layer is used as a magnetic flux concentrator providing a high magnetic gain. Therefore, the circuit features very high magnetic sensitivity, low offset, and low noise.

The CSA-1V is packaged in a standard SOIC-8 full plastic package. This package provides:

- highest isolation for applications with the current conductor on the PCB (up to 600V)
- highest sensitivity for applications with the current lead above the chip.

Package: SOIC-8

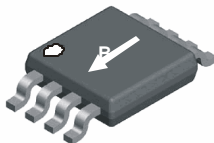
Pin Out:

- 1 A_OUT, analog sensor output
- 2 V_{DD} pos. supply voltage
- 3 Not connected
- 4 PV, programming voltage ¹⁾
- 5 GND, supply common
- 6 PD, programming data ¹⁾
- 7 PC, programming clock ¹⁾
- 8 CO_OUT, common output

Note 1: Used for factory programming

Manufactured by: Sentron AG (A Melexis Company) · Baarerstrasse 73 · 6300 Zug · Switzerland · Tel: +41 (41) 711 2170 · Fax: +41 (41) 711 2188 · www.sentron.ch · sales@sentron.ch

GMW Associates, 955 Industrial Rd, San Carlos, CA 94070
www.gmw.com · Tel: (650) 802-8292 · Fax: (650) 802-8298 · Email sales@gmw.com

Absolute Maximum Ratings

Symbol	Parameter	Min.	Typ.	Max.	Unit	Remarks
V _{SUP}	Supply Voltage	0		6	V	
T	Ambient Temperature	-40		+150	°C	

Recommended Operating Conditions

Symbol	Parameter	Min.	Typ.	Max.	Unit	Remarks
V _{SUP}	Supply Voltage	4.5	5	5.5	V	
I _{OUT}	Output Current	-1		1	mA	
C _L	Load Capacitance			1000	pF	

Electrical Characteristics

 At T=-40°C to 150°C, V_{SUP}=4.5V to 5.5V if not otherwise specified.

Symbol	Parameter	Min.	Typ.	Max.	Unit	Test Conditions
I _{SUP}	Supply Current		11	16	mA	
V _{Common}	Common (reference) Output Voltage ²⁾	V _{SUP} /2 -20mV	V _{SUP} /2	V _{SUP} /2 +20mV		I _{OUT} =0mA
BW	Bandwidth: DC to		100		kHz	
t _R	Response Time			6	µs	

 Note 2: Ratiometric (proportional to V_{SUP})

Characteristics of the Linear Magnetic Field Sensor³⁴⁾

 With V_{SUP}= 5V and in the temperature range -40°C to 150°C, if not otherwise specified.

Symbol	Parameter	Min.	Typ.	Max.	Unit	Test Conditions
S	Magnetic Sensitivity ³⁾	270	280 ³⁾	290	V/T	B = B _L
ΔS/ΔT	Magn. Sensitivity Temperature Drift	-		0.02	%/°C	I _{OUT} =0mA T=-20°C to 125°C
V _{off}	Offset Voltage ³⁾	-15	0	15	mV	B=0T, I _{OUT} =0mA, T=20°C
B _{off}	Equivalent Magnetic Offset ³⁾	-50	0	50	µT	B=0T, I _{OUT} =0mA T=-20°C to 80°C
ΔV _{off} /ΔT	Offset Temperature Drift	-0.2	0	0.2	mV/°C	B=0T, I _{OUT} =0mA, T=-20°C to 125°C
B _{FS}	Full Scale Magnetic Field Range ⁵⁾	-7.5		7.5	mT	
B _L	Linear Magnetic Field Range	-5		5	mT	
NL	Non Linearity		0.1	0.2	%	B = B _L
			0.5	1		B = B _{FS}
ΔB _{noise}	Input referred magnetic noise spectrum density (RMS)			125	nT/√Hz	f=10Hz to 10kHz

 Note 3: Ratiometric (proportional to V_{SUP})

 Note 4: When the analog output pin A_OUT is used in differential mode (ie V_{out} = A_OUT - CO_OUT)

 Note 5: Device saturates for B>B_{FS} but is not damaged

Note 6: Specification correction: Was 300±10 V/T. Now 280±10 V/T. All parts manufactured to date, have been calibrated to 280±10 V/T

Manufactured by: Sentron AG (A Melexis Company) · Baarerstrasse 73 · 6300 Zug · Switzerland · Tel: +41 (41) 711 2170 · Fax: +41 (41) 711 2188 · www.sentron.ch · sales@sentron.ch

 GMW Associates, 955 Industrial Rd, San Carlos, CA 94070
 www.gmw.com. Tel: (650) 802-8292. Fax: (650) 802-8298. Email sales@gmw.com

Block Diagram

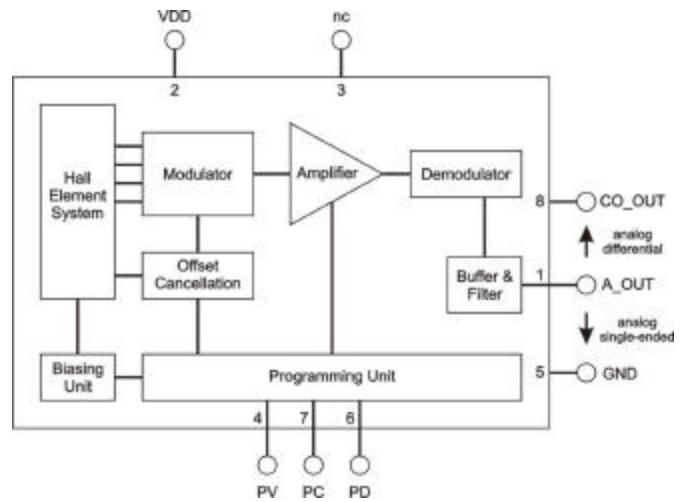
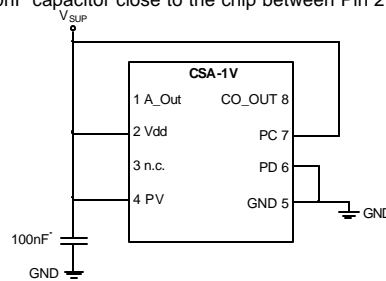

Fig. 1 Block diagram of CSA-1V

IMPORTANT

For reliable operation within the specifications the sensor must be connected as follows:

- Connect Pin 6 (PD) to Pin 5 (GND)
- Connect Pin 7 (PC) to Pin 2 (Vdd)
- Connect Pin 4 (PV) to Pin 2 (Vdd)
- Put a 100nF capacitor close to the chip between Pin 2 (Vdd) and Pin 5 (GND)



* If the supply voltage is disturbed by EMI it can be useful to place a second capacitor (100pF, ceramic) parallel to the 100nF capacitor.

Fig. 2 Connection diagram of CSA-1V

Manufactured by: Sentron AG (A Melexis Company) · Baarerstrasse 73 · 6300 Zug · Switzerland · Tel: +41 (41) 711 2170 · Fax: +41 (41) 711 2188 · www.sentron.ch · sales@sentron.ch

GMW Associates, 955 Industrial Rd, San Carlos, CA 94070
www.gmw.com. Tel: (650) 802-8292. Fax: (650) 802-8298. Email sales@gmw.com

Package Information SOIC-8

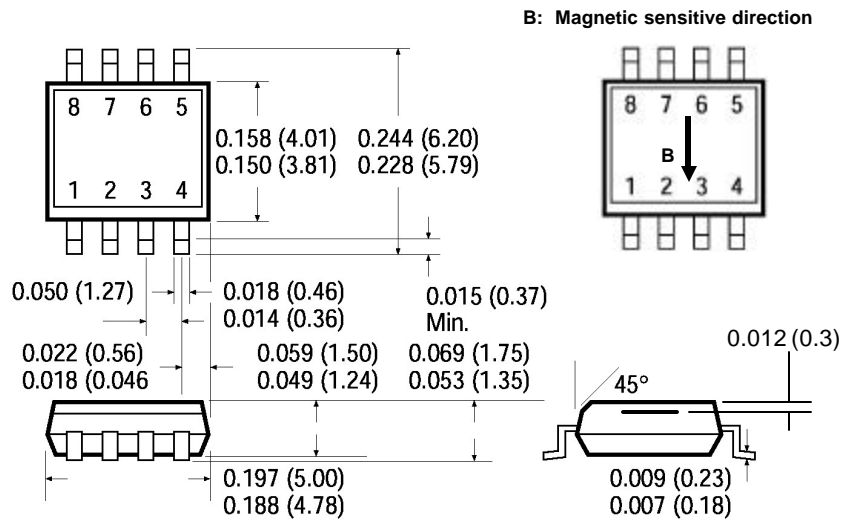

Fig. 3 Package information and magnetic sensitive direction

Ordering Information

Order part number: **CSA-1V-SO**

Parts are supplied on tape and reels.

Quantities below 2600 pcs are available in cut reels to the quantity ordered
 Quantities above 2600 pcs are available in complete 13", 2600 pc reels

Manufactured by: Sentron AG (A Melexis Company) · Baarerstrasse 73 · 6300 Zug · Switzerland · Tel: +41 (41) 711 2170 · Fax: +41 (41) 711 2188 · www.sentron.ch · sales@sentron.ch

GMW Associates, 955 Industrial Rd, San Carlos, CA 94070
 www.gmw.com. Tel: (650) 802-8292. Fax: (650) 802-8298. Email sales@gmw.com