

**PROPRIETARY**

THIS DRAWING CONTAINS CONFIDENTIAL INFORMATION PROPRIETARY TO GMW INC. IT MUST NOT BE REPRODUCED OR DISCLOSED TO OTHERS OR USED IN ANY OTHER WAY, IN WHOLE OR IN PART EXCEPT AS AUTHORIZED IN WRITING BY GMW INC.

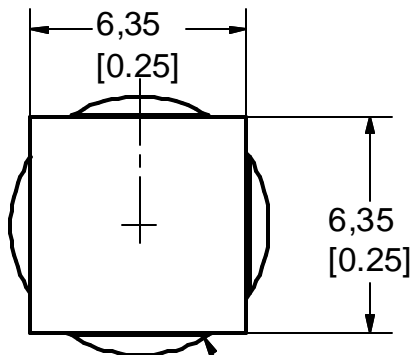

R3.81  
[0.15]

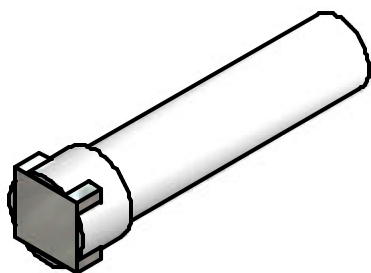
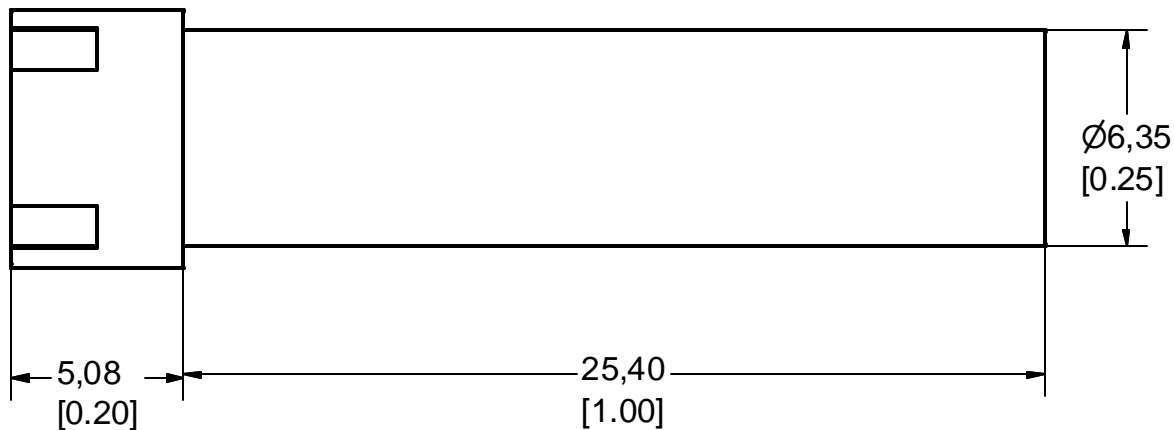

DRAWN KLL	Date 03/29/07	<b>DO NOT SCALE FROM DRAWING</b> DIMENSIONS & TOLERANCES UNLESS OTHERWISE SPECIFIED <table border="1"> <thead> <tr> <th>LINEAR</th> <th>INCHES</th> <th>mm</th> </tr> </thead> <tbody> <tr> <td>X.XXX</td> <td>±.005</td> <td>±0.03</td> </tr> <tr> <td>XXX</td> <td>±.01</td> <td>±0.1</td> </tr> <tr> <td>XX</td> <td>±.03</td> <td>±0.3</td> </tr> <tr> <td>X</td> <td>±.06</td> <td>±1</td> </tr> <tr> <td>DEG.</td> <td>±.5</td> <td>±0.5</td> </tr> </tbody> </table>	LINEAR	INCHES	mm	X.XXX	±.005	±0.03	XXX	±.01	±0.1	XX	±.03	±0.3	X	±.06	±1	DEG.	±.5	±0.5	<b>GMW Associates</b> 955 Industrial Road, San Carlos, CA 94070 Tel: (650) 802-8292. Fax: (650) 802-8298	
LINEAR	INCHES		mm																			
X.XXX	±.005		±0.03																			
XXX	±.01	±0.1																				
XX	±.03	±0.3																				
X	±.06	±1																				
DEG.	±.5	±0.5																				
CHECK	Date	TITLE <b>M250SQ-1.0</b> <b>SQ Magnet - Holder Assy</b>																				
ENGINEERING KLL	Date	SIZE: <b>A4</b> DRAWING No.: <b>11900-2030-0</b> REV:																				
Shaft Material: Aluminum Magnet: 55C0126 (SmCo24)		SCALE:      WT:      kg      SHEET:      OF:																				

