

# EW-750B

Shipped in bulk(500pcs/Reel)

EW-750B is composed of a Ultra-high sensitive InSb Hall element and a signal processing IC chip in a package.

Unipolar Hall Effect Switch	Supply Voltage 3~26.4V	Hall Element Continuous Excitation	Standard Sensitivity Bop:6mT	Output Open Collector	SIP
-----------------------------	---------------------------	------------------------------------	---------------------------------	-----------------------	-----

Notice:It is requested to read and accept "IMPORTANT NOTICE" written on the back of the front cover of this catalogue.

## ●Operational Characteristics

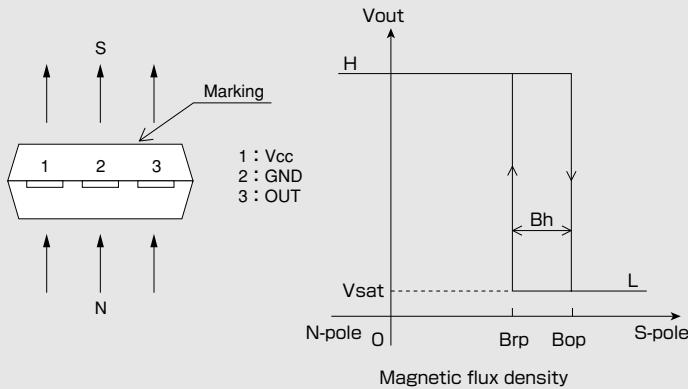

## ●Absolute Maximum Ratings (Ta=25°C)

Item	Symbol	Limit	Unit
Supply Voltage	V <sub>CC</sub>	26.4(*)	V
Output H Voltage	V <sub>O(off)</sub>	V <sub>CC</sub>	V
Output L Current	I <sub>sink</sub>	10	mA
Operating Temperature Range	Topr	-40 ~ 115	°C
Storage Temperature Range	Tstg	-40 ~ 125	°C

(\*) Please refer to Supply Voltage Derating Curve.

## ●Functional Block Diagram

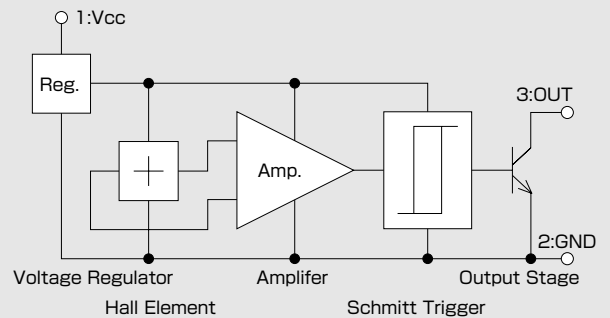

Another product type with pulled-up resistor(EW-752B). Please contact AKEMD to obtain the detail information.

## ●Magnetic and Electrical Characteristics (Ta=25°C)

Item	Symbol	Conditions	Min.	Typ.	Max.	Unit
Supply Voltage	V <sub>CC</sub>		3	12	26.4	V
Operating Point	B <sub>OP</sub>	V <sub>CC</sub> =12V	3	6	10	mT
Release Point	B <sub>rp</sub>	V <sub>CC</sub> =12V	2.5	5	9.5	mT
Hysteresis	B <sub>h</sub>	V <sub>CC</sub> =12V	0.5	1.1	2.5	mT
Output Saturation Voltage	V <sub>sat</sub>	V <sub>CC</sub> =12V,OUT"L",I <sub>sink</sub> =10mA			0.4	V
Output Leakage Current	I <sub>leak</sub>	V <sub>CC</sub> =12V,OUT"H",V <sub>out</sub> =12V			1	μA
Supply Current	I <sub>CC</sub>	V <sub>CC</sub> =12V,OUT"H"		5	6	mA

1 [mT] = 10 [Gauss]

•Please be aware that our products are not intended for use in life support equipment, devices, or systems. Use of our products in such applications requires the advance written approval of our sales staff. Certain applications using semiconductor devices may involve potential risks of personal injury, property damage, or loss of life. In order to minimize these risks, adequate design and operating safeguards should be provided by the customer to minimize inherent or procedural hazards. Inclusion of our products in such applications is understood to be fully at the risk of the customer using our devices or systems.

●Package (Unit:mm)

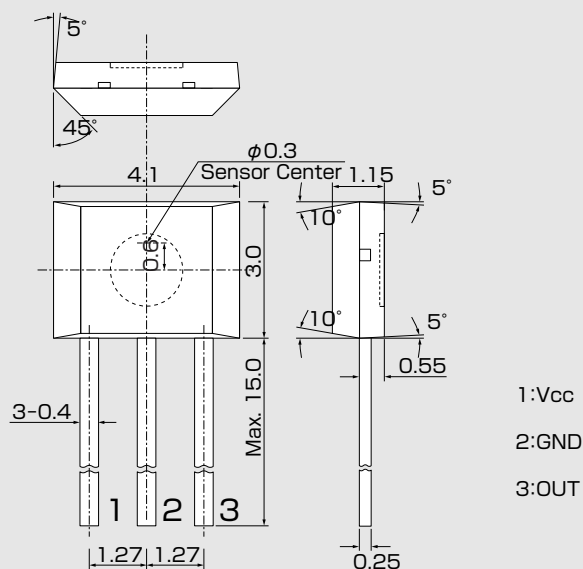

Note) The sensor center is located within the  $\phi 0.3$ mm circle.

●Supply Voltage

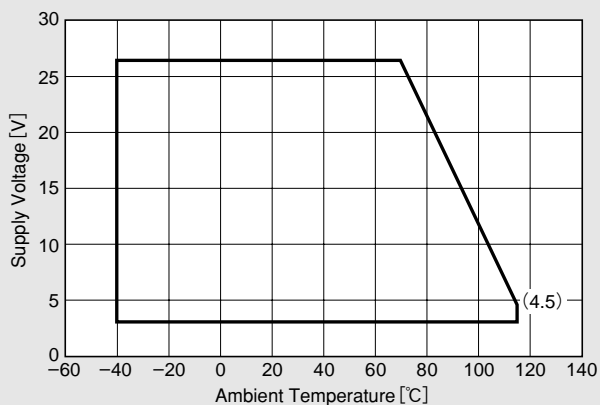

●Temperature Dependence of Bop, Brp

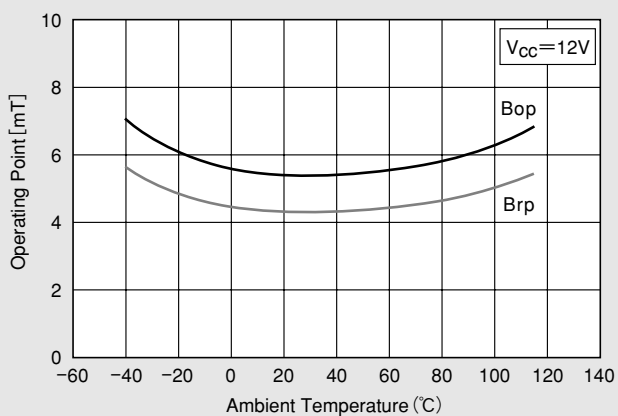

●Supply Voltage Dependence of Bop, Brp

