

EM-1791

Shipped in packet-tape reel(5000pcs/Reel)

EM-1791 is ultra-small Hall effect ICs of a single silicon chip composed of Hall element and a signal processing IC.

Unipolar Hall Effect Switch
Two output for S and N-pole

Supply Voltage
1.6~5.5V

Hall Element Pulse Excitation

High Sensitivity
Bop:2.5mT

Output CMOS
Two output for S and N-pole

SMT

Notice:It is requested to read and accept "IMPORTANT NOTICE" written on the back of the front cover of this catalogue.

●Operational Characteristics

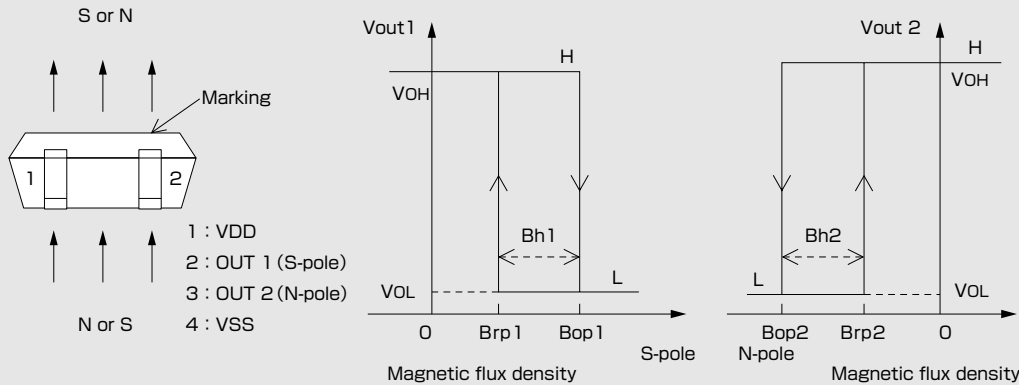

●Functional Block Diagram

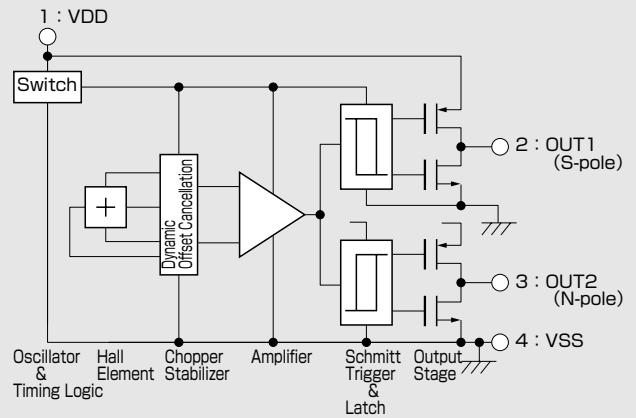

●Absolute Maximum Ratings (Ta=25°C)

Item	Symbol	Limit	Unit
Supply Voltage	VDD	-0.1 ~ 6.0	V
Output Current	I _{out}	±0.5	mA
Operating Temperature Range	Topr	-30 ~ +85	°C
Storage Temperature Range	Tstg	-40 ~ +125	°C

●Magnetic ① and Electrical Characteristics (Ta=25°C VDD=1.85V)

Item	Symbol	Conditions	Min.	Typ.	Max.	Unit
Supply Voltage	VDD		1.6		5.5	V
Operating Point	B _{Op1}		*1.4	2.5	3.2	mT
	B _{Op2}		-3.2	-2.5	*-1.4	
Release Point	B _{Rp1}		1.2	2.0	*3.0	mT
	B _{Rp2}		*-3.0	-2.0	-1.2	
Hysteresis	B _{h1} , B _{h2}			0.5		mT
Period	T _p			50	100	ms
Output High Voltage	V _{OH}	I _o =-0.2mA	VDD-0.4			V
Output Low Voltage	V _{OL}	I _o =+0.2mA			0.4	V
Supply Current	I _{DD}	Average		6.5	9	μA

1 [mT]=10 [Gauss]

* The characteristics with [*] marks are design targets.
* OUT1 responds to the positive flux from the south pole(Bop1,Brp1), OUT2 to the negative flux from the north pole(Bop2,Brp2).

●Magnetic Characteristics ② (Ta=-30~+85°C VDD=1.85V)

Item	Symbol	Conditions	Min.	Typ.	Max.	Unit
Operating Point	B _{OpS}		1.3	2.5	3.5	mT
	B _{OpN}					
Release Point	B _{RpS}		1.1	2.0	3.3	mT
	B _{RpN}					
Hysteresis	B _{hS}			0.5		mT
	B _{hN}					

Note) The above specifications are design targets.

●Application Circuit

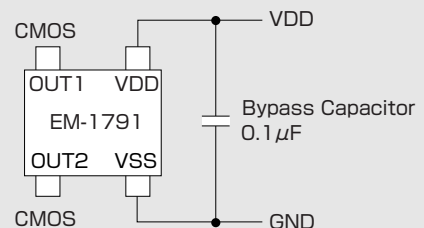

•Please be aware that our products are not intended for use in life support equipment, devices, or systems. Use of our products in such applications requires the advance written approval of our sales staff.
 Certain applications using semiconductor devices may involve potential risks of personal injury, property damage, or loss of life. In order to minimize these risks, adequate design and operating safeguards should be provided by the customer to minimize inherent or procedural hazards. Inclusion of our products in such applications is understood to be fully at the risk of the customer using our devices or systems.

●Package (Unit:mm)

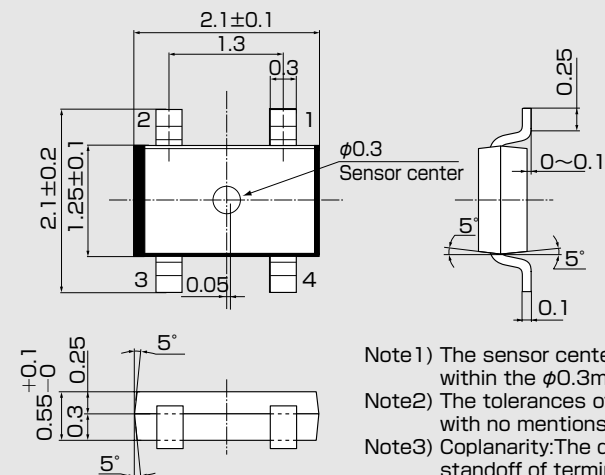

Pin No.	Connection	Function	Comment
1	VDD	Supply Voltage	
2	OUT1	Output Voltage	S-pole
3	OUT2	Output Voltage	N-pole
4	VSS	GND	

- Note1) The sensor center is located within the $\phi 0.3$ mm circle.
- Note2) The tolerances of dimensions with no mentions is ± 0.1 mm.
- Note3) Coplanarity: The differences between standoff of terminals are max.0.1mm.
- Note4) The sensor part is located 0.4mm(typ.) far from marking surface.

●(For reference only)Land Pattern (Unit:mm)

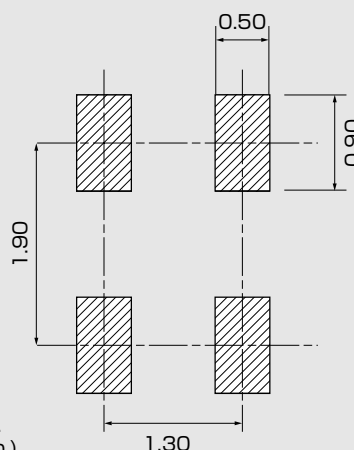

●Function Timing Chart

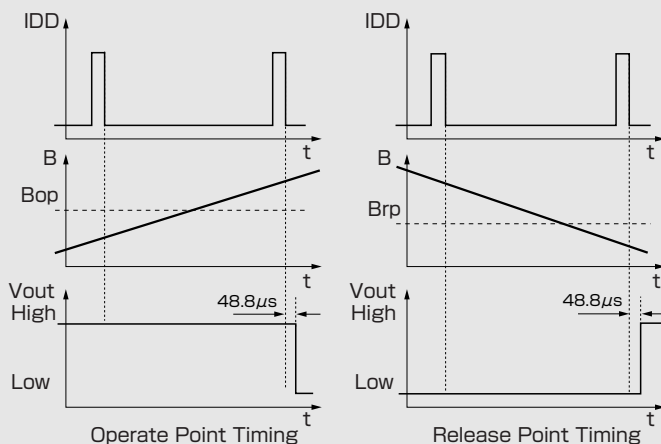

This Hall IC's output is held as internal data just before the internal circuit turns OFF (IDD OFF). And after 48.8 μ s, the output changes.
 Note) 48.8 μ s in figures is typical value

●IDD Pulse Driving (VDD=1.85V)

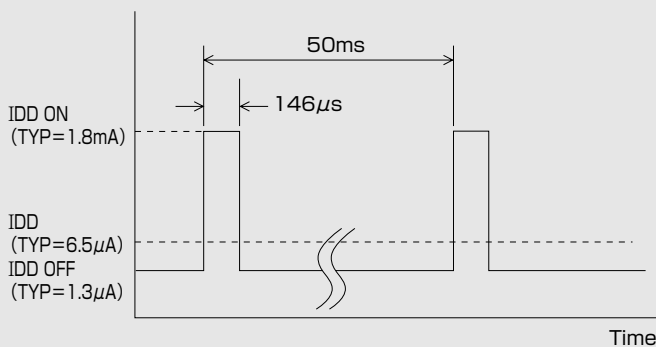

●Supply Voltage

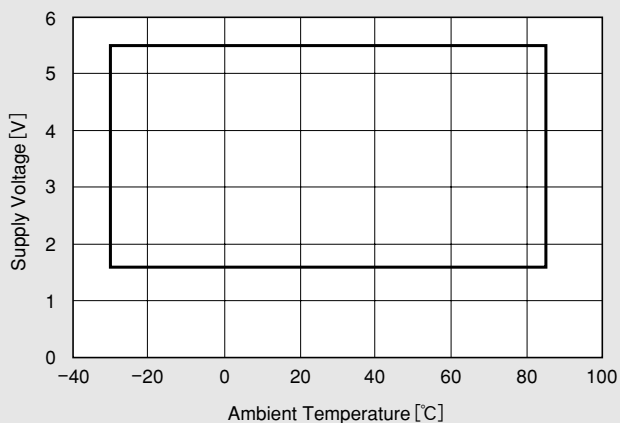

●Temperature Dependence of Bop, Brp

