

Angular Position Sensing (EM-3242) (Preliminary Specification)

All values specified in this data sheet are target specifications and are not guaranteed. The specifications are subject to change without notice.

Features

- Angular position sensing with Hall effect device
- Non contact rotation angle sensing by coin shape magnet and magnetic sensing IC
- Very small package with good stability against temperature change
- Single operative voltage **3 ~ 5V**



Outline

EM-3242 outputs analog signal proportional to angular position of magnet using signal from Hall sensors and the signal s processing. The combination **EM-3242** with coin shape magnet realizes non contact angular position sensing features. Very wide variety of magnets can be used for the measurement, and very stable output without any significant error can be available even if the magnet has some temperature dependency

Block diagram

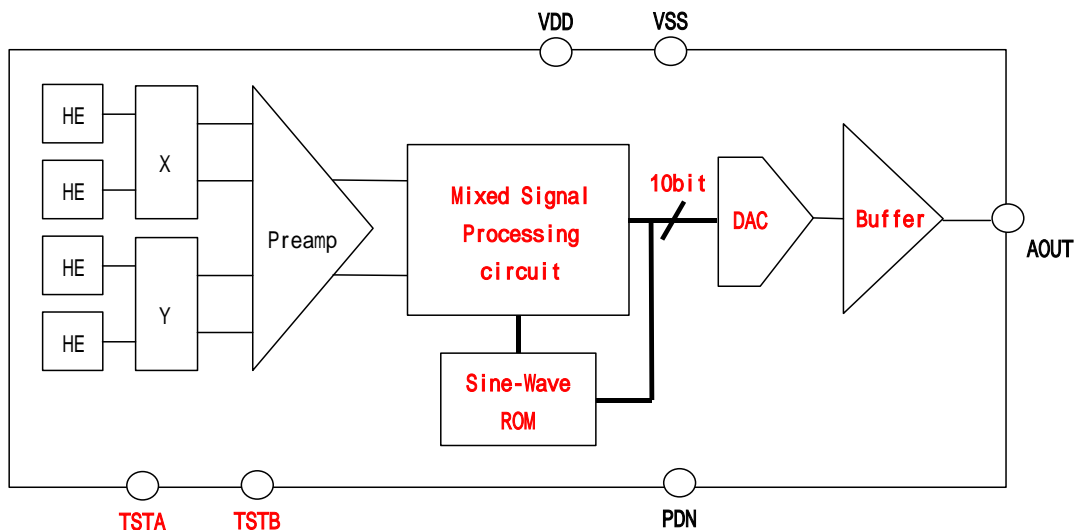

Absolute maximum rating

Symbol	Parameters	Min.	Typ.	Max.	Unit	Remarks
VDD	Supply voltage	-0.3		6.5	V	
T _{Stg}	Storage temperature	-40		125	°C	

Recommended operating condition

Symbol	Parameters	Min.	Typ.	Max.	Unit	Remarks
VDD	Supply Voltage	2.7		5.5	V	
T _A	Operating Temperature	-30		85	°C	

Electric & Magnetic characteristics

Symbol	Parameters	Min.	Typ.	Max.	Unit	Remarks
B _{RANGE}	Detective Magnetic Range	20	35	50	mT	
A _{RANGE}	Detective angle range			360	Deg.	
A _{RES}	Angle Resolution		0.36		Deg	10bit
A _{PREC}	Angle preciseness	-2	0	2	Deg.	@25°C
A _{TD}	Angle Temperature Drift	-1	0	1	Deg.	@-30 ~ 85°C
BBW	Max. Rotation Speed			200	Hz	
T _a	Output Cycle		30		KHz	
T _d	Output signal delay		100	130	μs	
V _{OUT}	Output Voltage range	0.1VDD		0.9VDD	V	Ratio metric
I _{SUP}	Supply Current		8	12	mA	w/ sensor drive
I _{PD}				1	μA	Power-down
T _{PD}	Wake-up time		520	640	μs	PDN:L H
I _{OUT}	Output current			±0.3	mA	
CL	Load capacitance			200	pF	

Recommended Connection Diagram

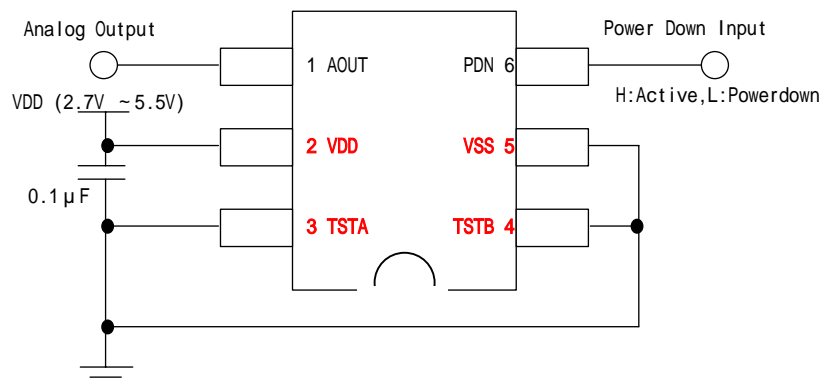

Absolute angle position & Magnet Position

Analog output increases with clockwise magnet rotation.

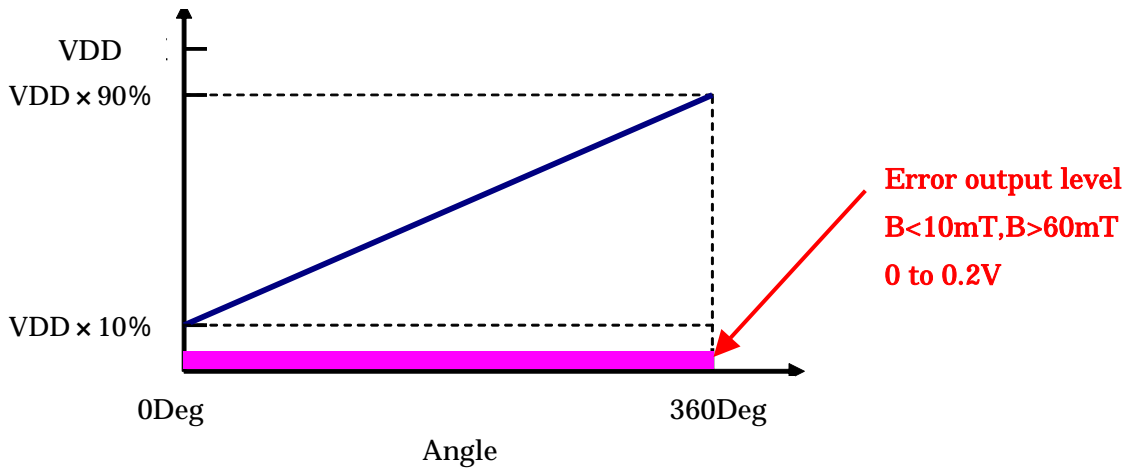
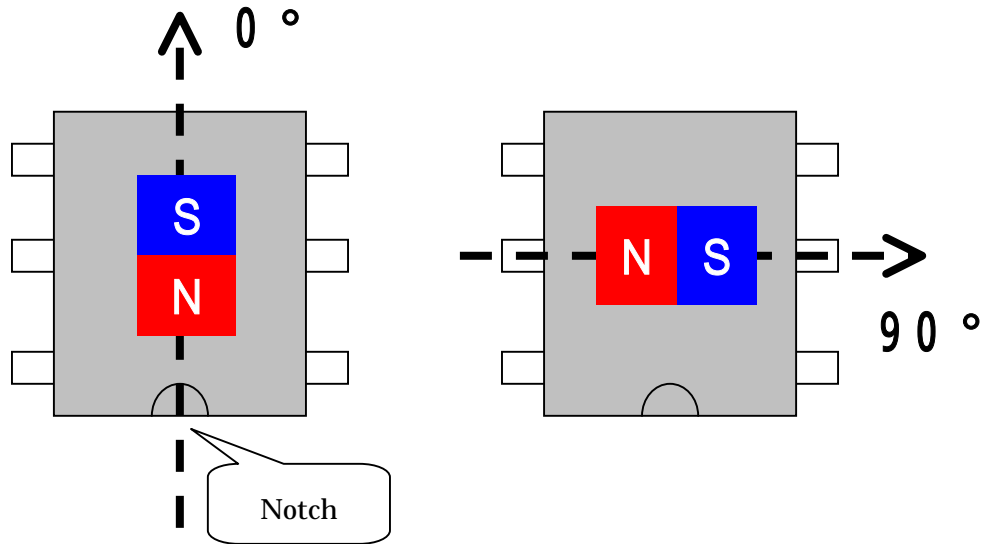

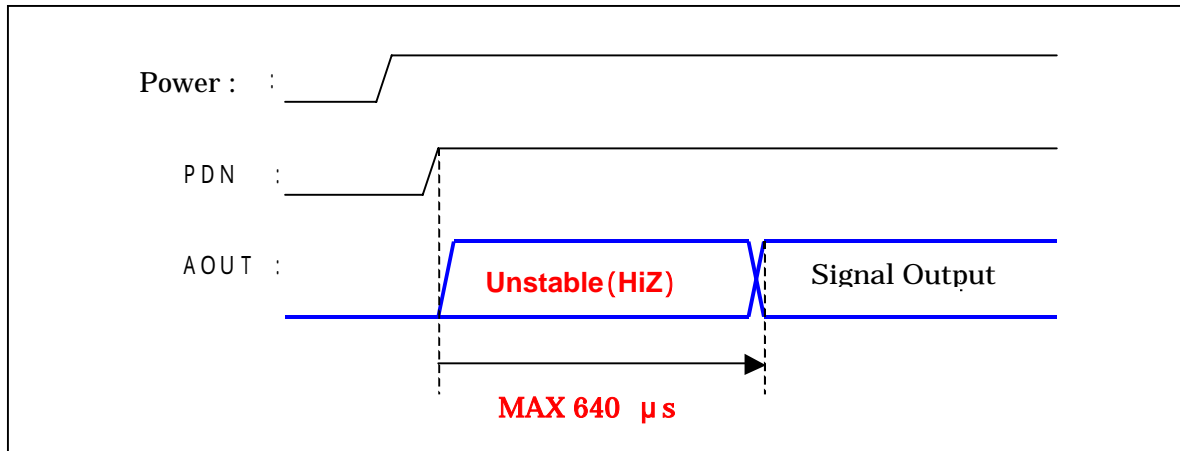
Timing chart for output

Please note there is “output unstable state”(HiZ) before actual signal outputs when the state is change from “Power Down” to “Active.”

Package

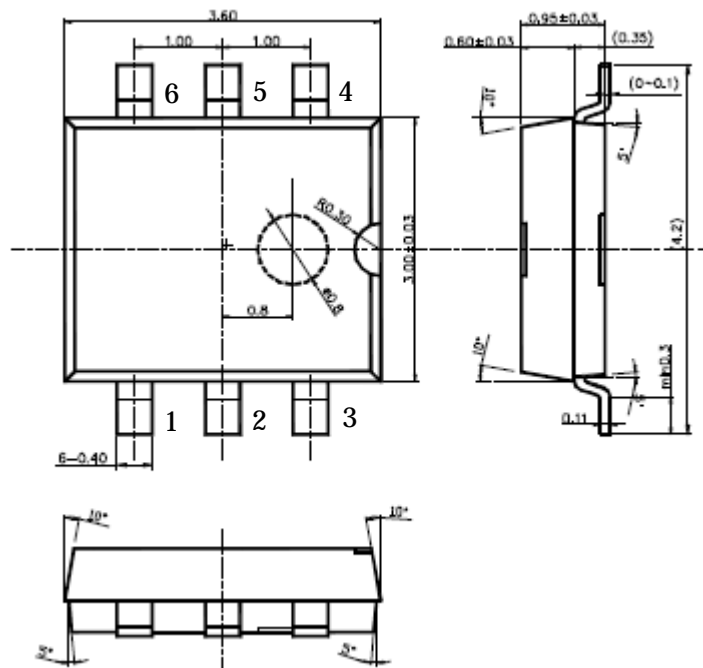

Pin No.	Name	Comments
1	AOUT	Sensor output
2	VDD	Power supply. Please see above "VSS" for capacitor attach
3	TSTA	Test pin A. Please connect to GND.
4	TSTB	Test pin B. Please connect to GND.
5	VSS	Ground pin. A ceramic capacitor (0.1μF) should be connected between VDD and VSS.
6	PDN	Power down. PDN=Logic High → IC active. Internally being pulled down and power-down state kept when reset(power on).

<i>Important Notice</i>

The information presented in this document has been carefully checked and is believed to be accurate, however, no responsibility is assumed for inaccuracies. Asahi Kasei EMD reserves the right to make changes to any specifications without further notice for performance, reliability, production technique and other considerations, Asahi Kasei-EMD does not assume any liability arising out of the application or use of products herein.

Asahi Kasei-EMD makes no warranty that the use of the innovative technology will not infringe on patent rights or other proprietary rights owned by others.