

Low current sensing with high voltage isolation

FEATURES

- Low current- three ranges (0.25A to 10A)
- High voltage isolation >4KV
- Linear analog voltage output
- Single 5 V Power Supply
- Low current consumption
- Through Hole Mounting
- Small Size

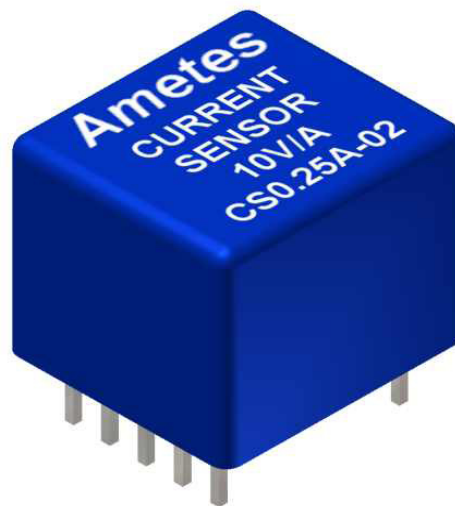

Available Configurations

| | | |
|------------|-----------------|---------------------|
| CS0.25A-02 | Fullscale 0.25A | 10V/A Sensitivity |
| CS2.5A-02 | Fullscale 2.5A | 1V/A Sensitivity |
| CS10A-02 | Fullscale 10A | 0.25V/A Sensitivity |

DESCRIPTION

The Ametes CS series current sensors offer low current sensing with high voltage isolation capability. The sensors can be connected for either bi-polar operation ($2.5V \pm 2.5V$) or uni-polar operation (0 to 5V). The uni-polar configuration has 2X sensitivity of the bi-polar configuration which provides a full scale output swing for the rated current. One mounting configuration available straight pin for through hole mounting. The Ametes sensor incorporates the Sentron CSA-1V high sensitivity Hall IC and a multi-turn coil to further increase sensitivity

Outline Drawing - Through Hole

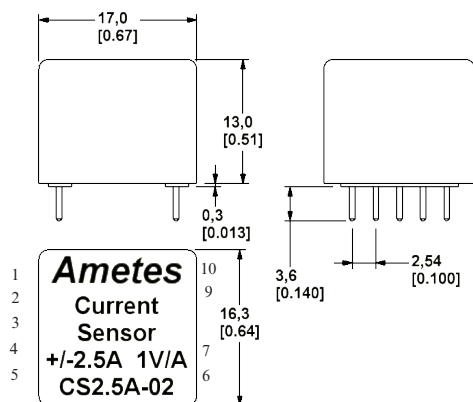

Schematic Diagram -Ametes CS Series Current Sensor

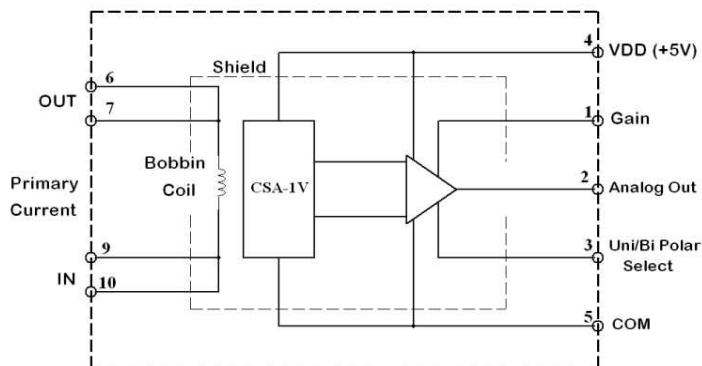

Revision Date: 31 OCT 2008, CS Series

European Distributor: Senis GmbH: Technoparkstrasse 1, 8005 Zurich, Switzerland. www.senis.ch. +44 (79) 266-8756

Americas Distributor: GMW Associates: 955 Industrial Road, San Carlos, CA 94070, USA. www.gmw.com. +1 (650) 802-8292

SPECIFICATIONS

Absolute Maximum Ratings

| Symbol | Parameter | Min. | Typ. | Max. | Unit | Remarks |
|------------------|--------------------------|------|------|------|------|----------------------|
| T _{STG} | Storage Temperature | -55 | | 100 | °C | |
| T _A | Ambient Temperature | -40 | | 85 | °C | With power applied |
| V _{DD} | Supply Voltage | -0.5 | | +6.0 | V | |
| ESD | Electro Static Discharge | 2000 | | | V | Human Body Model ESD |
| B | Magnetic Field | | | 1 | | Tesla |

Recommended Operating Conditions

| Symbol | Parameter | Min. | Typ. | Max. | Unit | Remarks |
|------------------|----------------|------|------|------|------|---------|
| V _{DD} | Supply Voltage | 4.5 | 5.0 | 5.25 | V | |
| I _{SUP} | Supply Current | | 9 | 15 | mA | |

Electrical Characteristics

Operating Conditions: V_{DD} = 5.00 V and T_A = 25° C

Note (1): Outputs are ratiometric to the supply voltage V_{DD}

| Sensor Model Numbers | | CS0.25-02 | | | CS2.5-02 | | | CS10.0-02 | | | | |
|----------------------|---|-----------|------|------|----------|-------|------|--------------------|-------|-------------------|--------|---|
| Sym | Parameter | Min | Typ | Max | Min | Typ | Max | Min | Typ | Max | Unit | Remarks |
| V _{out} | Analog output voltage range | .050 | | 4.95 | .050 | | 4.95 | .050 | | 4.95 | V | |
| V _q | Quiescent Voltage: Bi-Polar configuration | 2.47 | 2.50 | 2.53 | 2.47 | 2.50 | 2.53 | 2.47 | 2.50 | 2.53 | V | I _{pri} = 0A |
| V _q | Quiescent voltage: Uni-Polar config. | 0 | | 60 | 0 | | 60 | 0 | | 60 | mV | I _{pri} = 0A |
| S | Sensitivity: Bi-Polar | 9.5 | 10.0 | 10.5 | 0.95 | 1.00 | 1.05 | 0.24 | 0.25 | 0.26 | V/A | V _{out} range: 2.5 ± 2.5V |
| S | Sensitivity: Uni-Polar | 19 | 20 | 21 | 1.9 | 2.0 | 2.1 | .475 | .500 | .525 | V/A | V _{out} range: 0.050 - 4.95V |
| I _{pri} | Primary I: Bi-Polar | -0.25 | | 0.25 | -2.5 | | 2.5 | -10 ⁽¹⁾ | | 10 ⁽¹⁾ | A | Note 1 -40C to 30C continuous, 30C to 85C 5A continuous |
| I _{pri} | Primary I: Uni-Polar | 0 | | 0.25 | 0 | | 2.5 | 0 | | 10 ⁽¹⁾ | A | Note 1 -40C to 30C continuous, 30C to 85C 5A continuous |
| ΔS/ΔT | Sensitivity Temperature Drift | | ±200 | | | ±200 | | | ±200 | | PPM/°C | |
| T | Operating Temperature | -40 | | 85 | -40 | | 85 | -40 | | 85 | °C | |
| NL | Non Linearity | | 0.5 | 1 | | 0.5 | 1 | | 0.5 | 1 | % | V _{out} range: 0.050 - 4.95V |
| | Resolution | | ±0.1 | | | ±1 | | | ±4 | | mA | |
| | Noise | | < 5 | | | < 5 | | | < 5 | | mV | |
| V _{iso} | Dielectric Isolation Primary -Control Circuit | 4 | | | 4 | | | 4 | | | kV | DC |
| BW | Bandwidth | 0 | | 5000 | 0 | | 5000 | 0 | | 5000 | Hz | |
| R _{pri} | Primary Resistance | | 6 | | | 0.060 | | | 0.006 | | Ω | DC Resistance |
| L _{pri} | Primary Inductance | | 0.36 | | | 0.006 | | | 0.005 | | mh | |

Revision Date: 31 OCT 2008, CS Series

European Distributor: Senis GmbH: Technoparkstrasse 1, 8005 Zurich, Switzerland. www.senis.ch. +44 (79) 266-8756

Americas Distributor: GMW Associates: 955 Industrial Road, San Carlos, CA 94070, USA. www.gmw.com. +1 (650) 802-8292

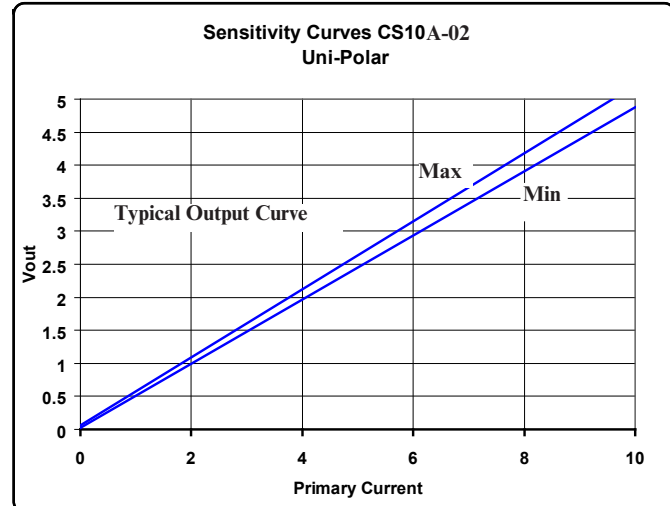
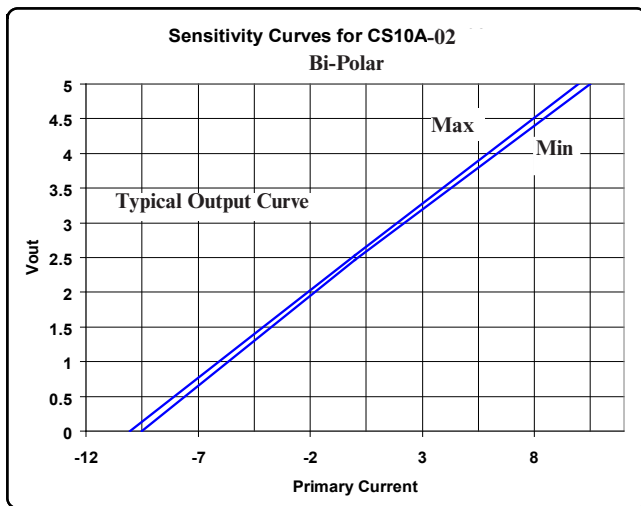
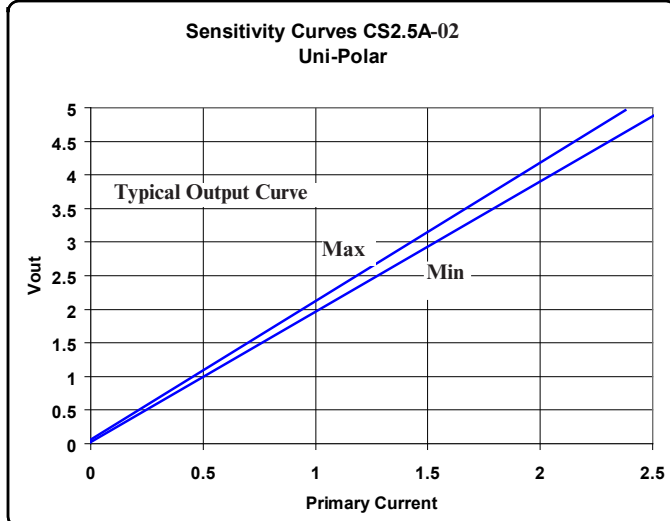
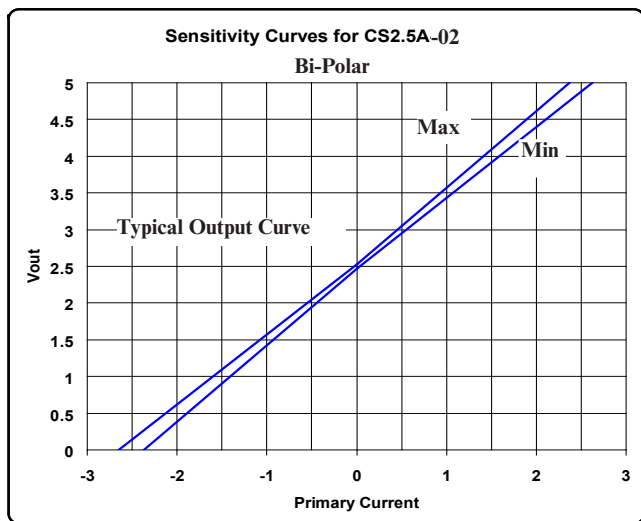
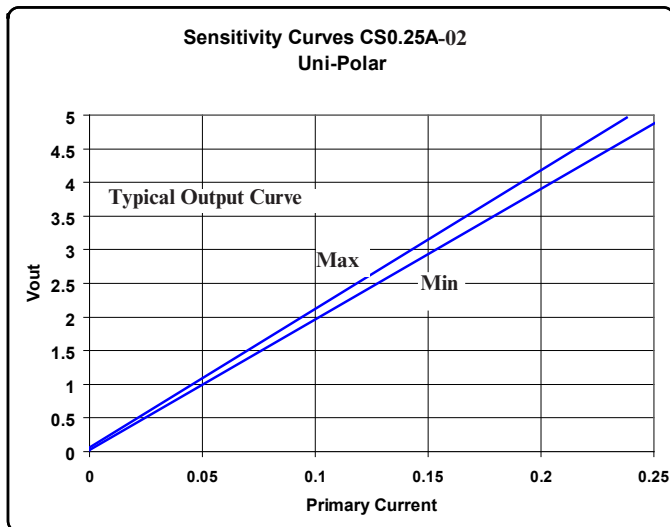
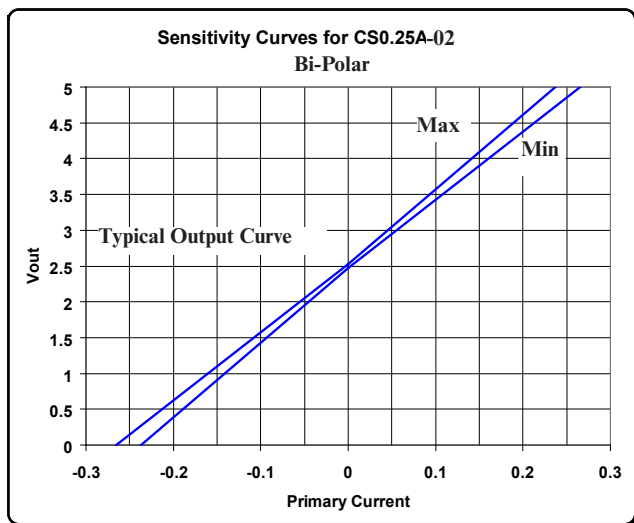

Revision Date: 31 OCT 2008, CS Series

European Distributor: Senis GmbH: Technoparkstrasse 1, 8005 Zurich, Switzerland. www.senis.ch. +44 (79) 266-8756

Americas Distributor: GMW Associates: 955 Industrial Road, San Carlos, CA 94070, USA. www.gmw.com. +1 (650) 802-8292

Connection Diagram for Bi-Polar Operation

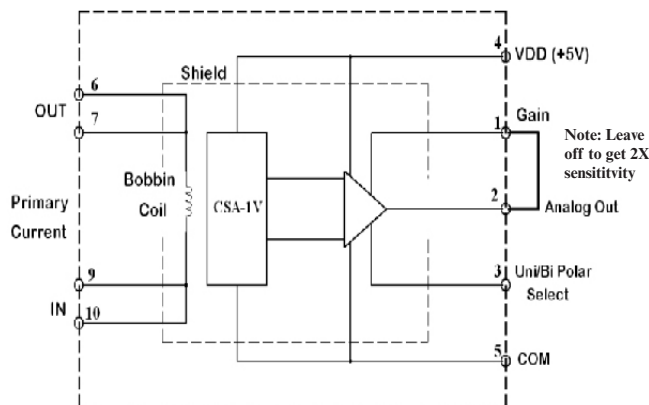

Connection Diagram for Uni-Polar Operation

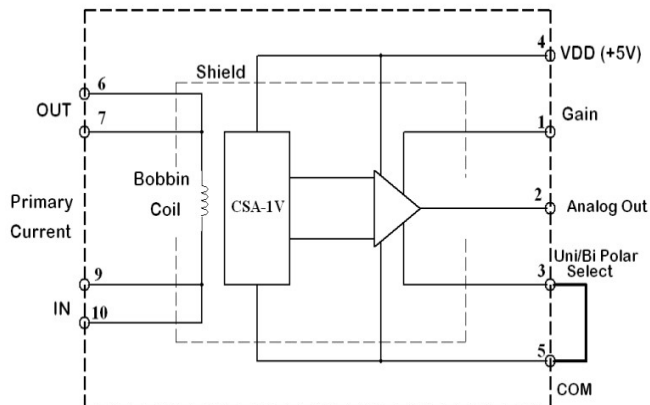

APPLICATION NOTES:

Bi-Polar & Uni-Polar operation

For bidirectional currents including AC currents, the sensor should be configured for Bi-Polar operation. This is accomplished by connecting the Analog Out (pin 2) to pin 1 (Gain) as shown in the schematic above. The output voltage will have a quiescent voltage of 2.5 V (50% of VDD) for “zero” current and will swing toward 5V for positive current and toward 0V for negative current.

The Sensitivity can be increased by a factor of two by leaving off the jumper between Pins 1 and 2. The output curves on page 3 will not apply for this configuration. Note: the 2X configuration will increase both the offset voltages and noise by a factor of 2.

For Uni-directional currents (DC), the sensor should be configured as shown in the above schematic for Uni-polar operation by connecting Pin 3 to COM (Pin 5). In this configuration the output quiescent voltage will be 0V (<0.060V) for “zero” current and will swing toward 5V for positive current into the “IN” pins, 9 and 10. Note: the minimum output voltage of the sensor amplifier is approximately 0.060 V, therefore the error at zero current will be slightly higher than the rest of the range.

Recommended PCB Hole Pattern

