

Low current sensing with high voltage isolation

FEATURES

- Low current- three ranges (0.25A to 10A)
- High voltage isolation >4KV
- Linear analog voltage output
- Single 5 V Power Supply
- Low current consumption
- SMD and Through Hole Mounting
- Small Size

DESCRIPTION

The Ametes CS series current sensors offer low current sensing with high voltage isolation capability. The sensors can be connected for either bi-polar operation (2.5V±2.5V) or uni-polar operation (0 to 5V). The uni-polar configuration has 2X sensitivity of the bi-polar configuration which provides a full scale output swing for the rated current. Two mounting configurations are available; straight pin for through hole mounting and right angle pins for SMD mounting. The Ametes sensor incorporates the Sentron CSA-1V high sensitivity Hall IC and a multi-turn coil to further increase sensitivity

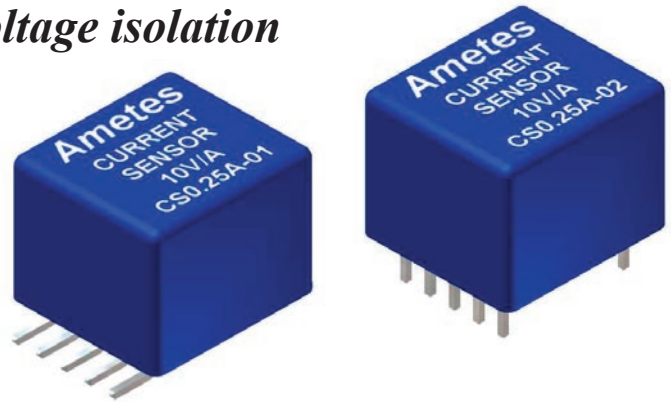

Available Configurations

CS0.25A-01	Fullscale 0.25A	10V/A Sensitivity	SMD
CS0.25A-02	Fullscale 0.25A	10V/A Sensitivity	TH
CS2.5A-01	Fullscale 2.5A	1V/A Sensitivity	SMD
CS2.5A-02	Fullscale 2.5A	1V/A Sensitivity	TH
CS10A-01	Fullscale 10A	0.25V/A Sensitivity	SMD
CS10A-02	Fullscale 10A	0.25V/A Sensitivity	TH

Schematic Diagram -Ametes CS Series Current Sensor

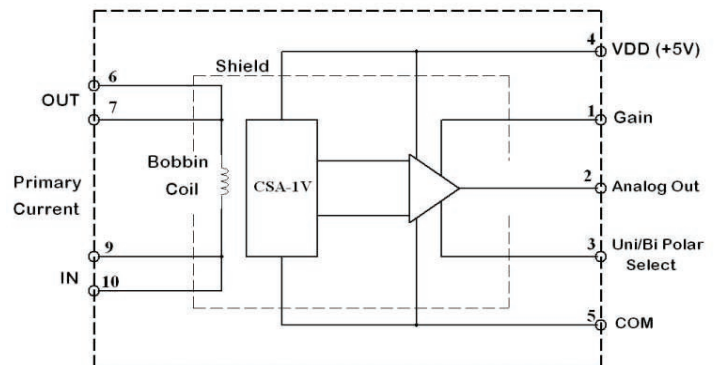

Outline Drawing - Surface Mount

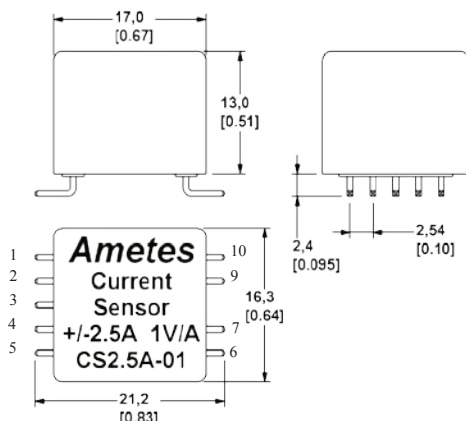

Outline Drawing - Through Hole

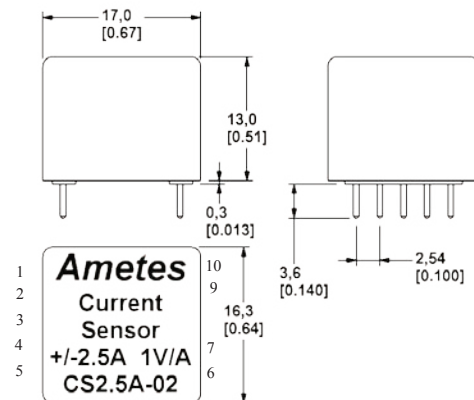

Revision Date:02 JAN, 2007, CS Series

SPECIFICATIONS

Absolute Maximum Ratings

Symbol	Parameter	Min.	Typ.	Max.	Unit	Remarks
T _{STG}	Storage Temperature	-55		100	°C	
T _A	Ambient Temperature	-40		85	°C	With power applied
V _{DD}	Supply Voltage	-0.5		+6.0	V	
ESD	Electro Static Discharge	2000			V	Human Body Model ESD
B	Magnetic Field			1		Tesla

Recommended Operating Conditions

Symbol	Parameter	Min.	Typ.	Max.	Unit	Remarks
V _{DD}	Supply Voltage	4.5	5.0	5.25	V	
I _{SUP}	Supply Current		9	15	mA	

Electrical Characteristics

Operating Conditions: V_{DD} = 5.00 V and T_A = 25° C

Note (1): Outputs are ratiometric to the supply voltage V_{DD}

Sensor Model Numbers		CS0.25-01,-02			CS2.5-01, -02			CS10.0-01,-02				
Sym	Parameter	Min	Typ	Max	Min	Typ	Max	Min	Typ	Max	Unit	Remarks
V _{out}	Analog output voltage range	.050		4.95	.050		4.95	.050		4.95	V	
V _q	Quiescent Voltage: Bi-Polar configuration	2.47	2.50	2.53	2.47	2.50	2.53	2.47	2.50	2.53	V	I _{pri} = 0A
V _q	Quiescent voltage: Uni-Polar config.	0		60	0		60	0		60	mV	I _{pri} = 0A
S	Sensitivity: Bi-Polar	9.7	10.0	10.3	0.97	1.00	1.03	0.242	0.250	0.258	V/A	V _{out} range: 2.5±2.5V
S	Sensitivity: Uni-Polar	19.4	20.0	20.6	1.94	2.0	2.06	.484	.500	.516	V/A	V _{out} range: 0.050 - 4.95V
I _{pri}	Primary I: Bi-Polar	-0.25		0.25	-2.5		2.5	-10 ⁽¹⁾		10 ⁽¹⁾	A	Note 1 -40C to 30C continuous, 30C to 85C 5A continuous
I _{pri}	Primary I: Uni-Polar	0		0.25	0		2.5	0		10 ⁽¹⁾	A	Note 1 -40C to 30C continuous, 30C to 85C 5A continuous
ΔS/ΔT	Sensitivity Temperature Drift		±200			±200			±200		PPM /°C	
T	Operating Temperature	-40		85	-40		85	-40		85	°C	
NL	Non Linearity		0.5	1		0.5	1		0.5	1	%	V _{out} range: 0.050 - 4.95V
	Resolution		±0.1			±1			±4		mA	
	Noise		< 5			< 5			< 5		mV	
V _{iso}	Dielectric Isolation Primary -Control Circuit	4			4			4			kV	DC
BW	Bandwidth	0		100	0		1000	0		4000	Hz	
R _{pri}	Primary Resistance		6			0.060			0.006		ohms	DC Resistance

Revision Date: 02 JAN, 2007, CS Series

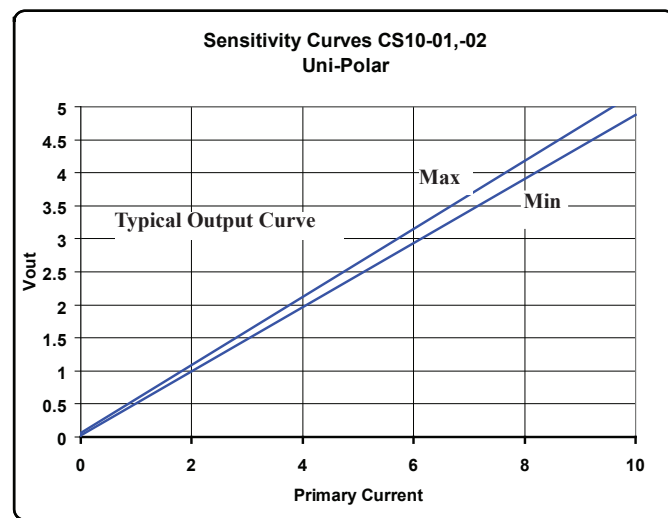
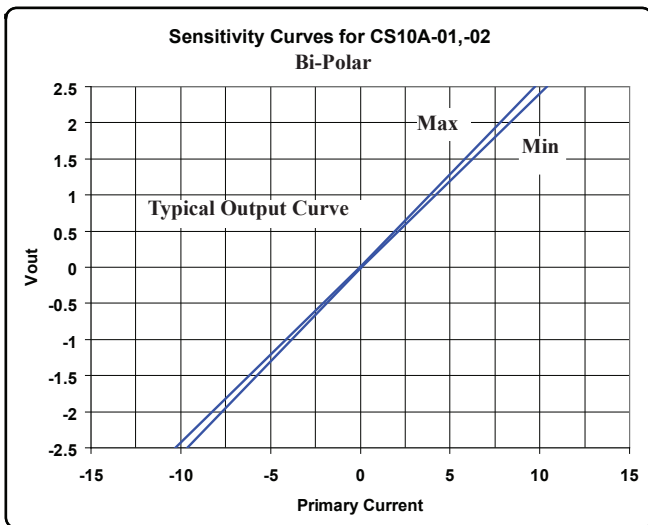
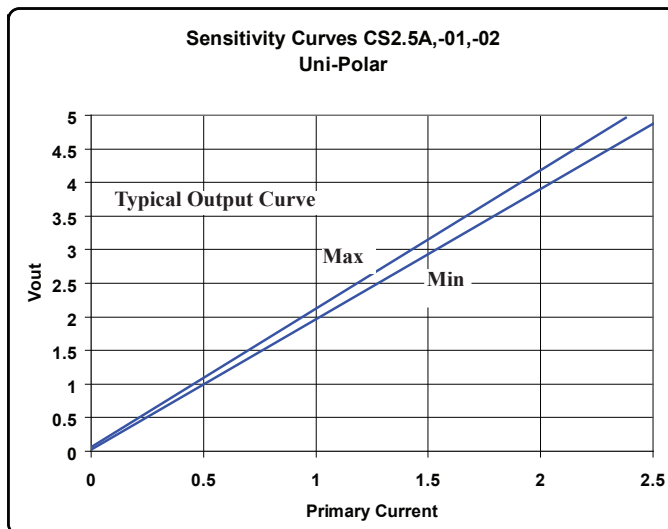
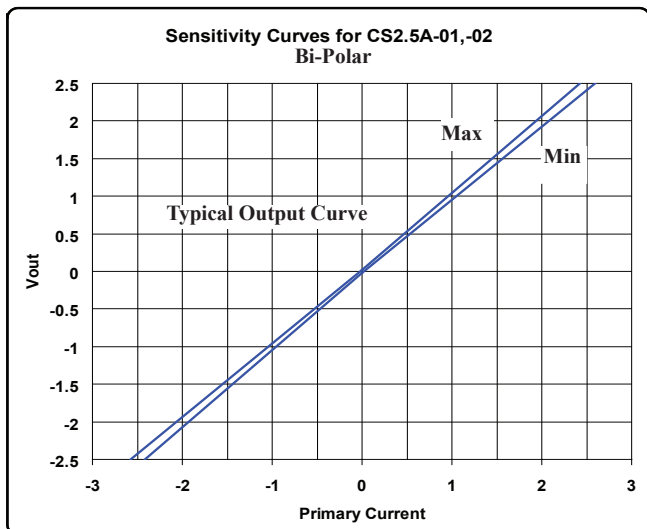
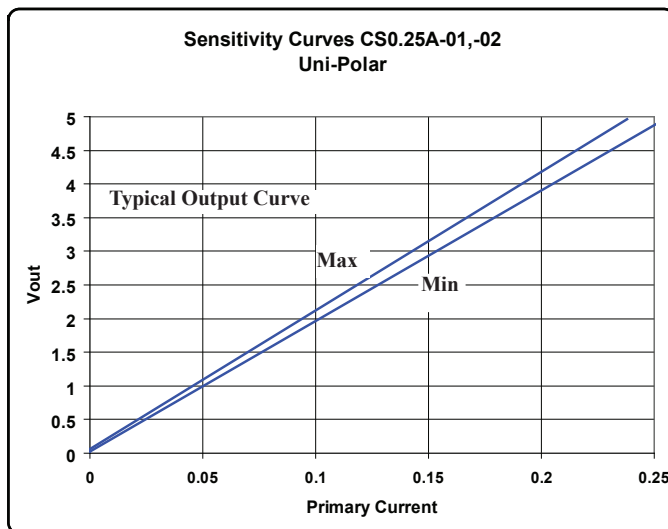
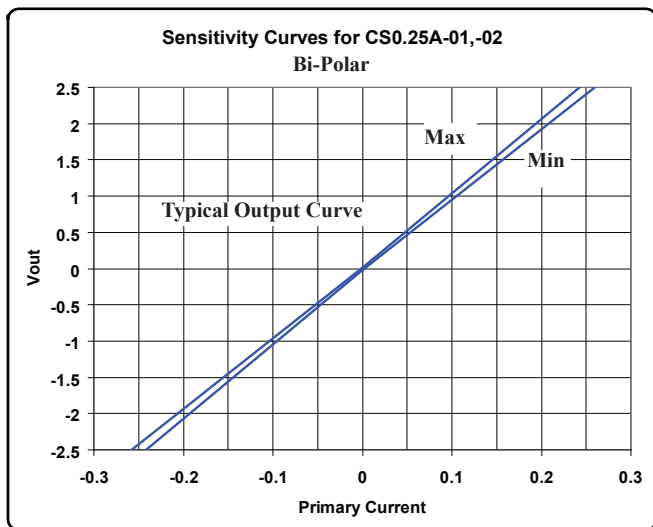

Revision Date:02 JAN, 2007, CS Series

Connection Diagram for Bi-Polar Operation

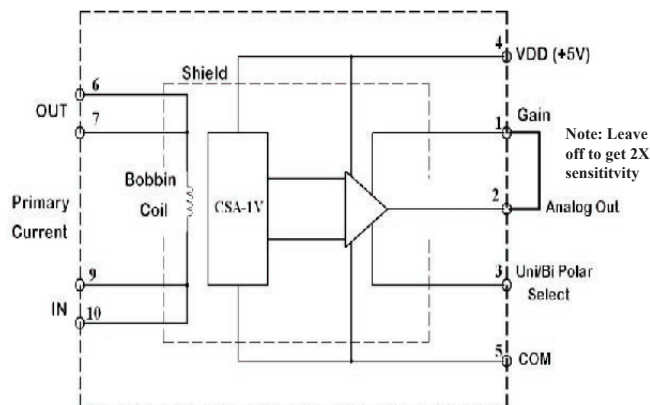

Connection Diagram for Uni-Polar Operation

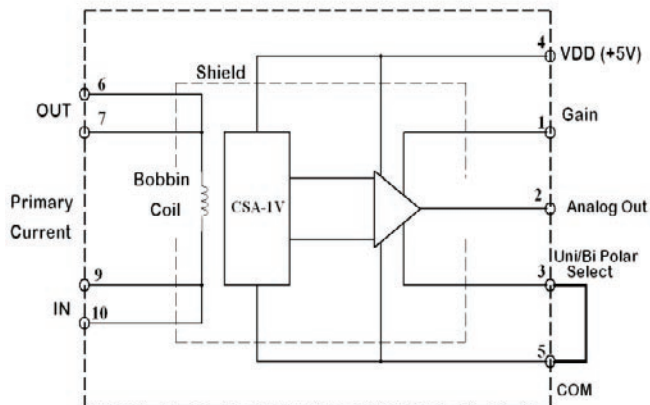

Application Notes:

Bi-Polar & Uni-Polar operation

For bidirectional currents including AC currents, the sensor should be configured for Bi-Polar operation. This is accomplished by connecting the Analog Out (pin 2) to pin 1 (Gain) as shown in the schematic above. The output voltage will have a quiescent voltage of 2.5 V (50% of VDD) for “zero” current and will swing toward 5V for positive current and toward 0V for negative current.

The Sensitivity can be increased by a factor of two by leaving off the jumper between Pins 1&2. The output curves on page 3 will not apply for this configuration. Note: the 2X configuration will increase both the offset voltages and noise by a factor of 2.

For Uni-directional currents (DC), the sensor should be configured as shown in the above schematic for Uni-polar operation by connecting Pin 3 to COM (Pin 5). In this configuration the output quiescent voltage will be 0V (<0.060V) for “zero” current and will swing toward 5V for positive current into the ”IN” pins, 9&10. Note: the minimum output voltage of the sensor amplifier is approximately 0.060 V, therefore the error at zero current will be slightly higher than the rest of the range.