

Magnetic Coupled, Minature, Flat Profile

FEATURES

- Magnetic Coupling for Mechanical Isolation
- Eliminates Mechanical loading by Angle Sensor
- Tolerates Axial and Radial Misalignment
- Enables “Through-Wall” Angle Sensing
- Analog Output Proportional to Angle
- Four Standard Angle Ranges up to 360 degrees
- Angle Resolution to 10 bits (0.1%) of Full scale
- Electronic Setting of Zero Angle
- Single 5V Power Supply
- Encapsulated Package only 3.4 mm (0.14”) Thin
- Integral Mounting and Grounding Tabs

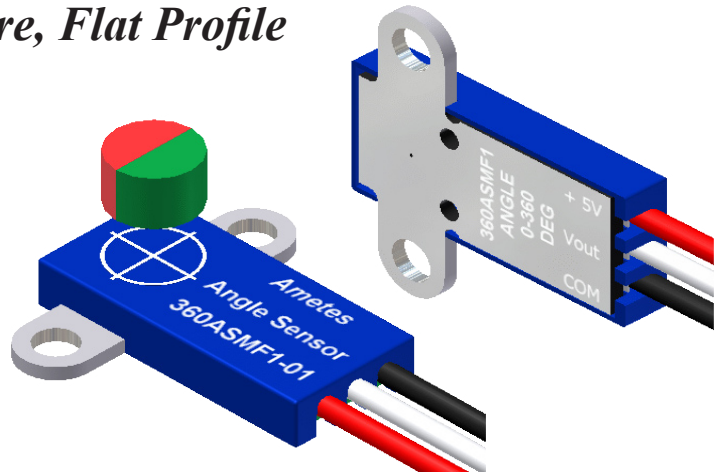

DESCRIPTION

The Ametes 360ASMF series Angle Sensor Modules integrate the Sentron 2SA-10 Two-Axis Hall IC with a Cypress PSoC processor for non-contact, absolute angle measurement. The 360ASMF provides an analog output signal which is proportional to the mechanical angle of a magnet with a resolution of 10 bits for each angle range. There are four “full scale output” ranges available. In addition to the absolute angle position output, the 360ASMF series detects when the field strength of the magnet is too low and sets the output voltage to 0V. The electrical “Zero Angle” position for each range can be set to correlate to any mechanical position within 360 degrees.

Ranges:

360ASMF1-01	0-360 Degrees (0.5V to 4.5V output)
360ASMF2-01	0-30 Degrees (0.5V to 4.5V output)
360ASMF3-01	0-90 Degrees (0.5V to 4.5V output)
360ASMF4-01	0±90 Degrees (2.5V to 2.0V output)

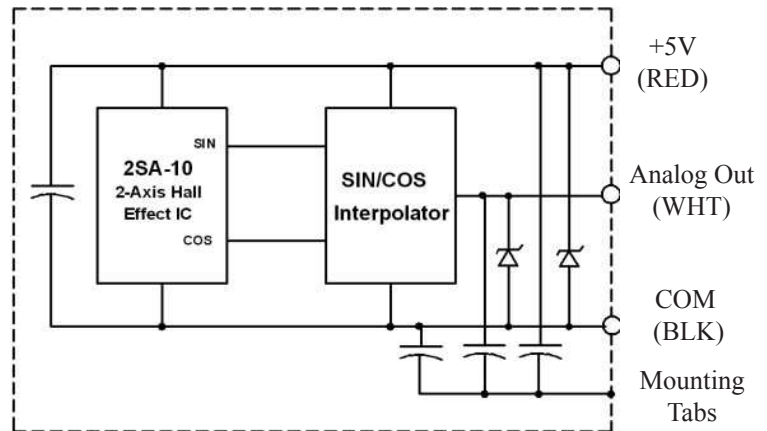

Schematic Diagram -Ametes 360ASMF Series

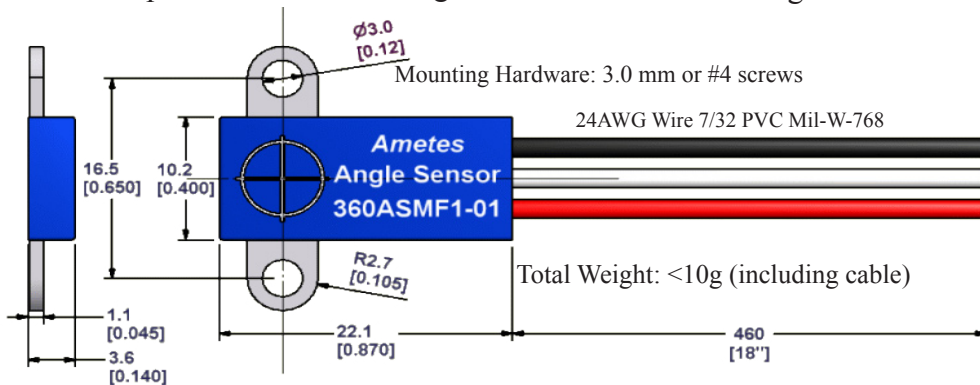

Mechanical Outline Drawing -Ametes 360ASMF Series

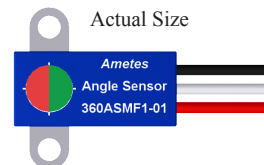

Revision Date 07 May, 2007, 360ASMF

SPECIFICATIONS

Absolute Maximum Ratings

Symbol	Parameter	Min.	Typ.	Max.	Unit	Remarks
T _{STG}	Storage Temperature	-55		100	°C	
T _A	Ambient Temperature	-40		85	°C	With power applied
V _{SUP}	Supply Voltage	-0.5		+6.0	V	
ESD	Electro Static Discharge	2000			V	Human Body Model ESD
B	Magnetic Field			1	T	

Recommended Operating Conditions

Symbol	Parameter	Min.	Typ.	Max.	Unit	Remarks
V _{SUP}	Supply Voltage	4.75	5.0	5.25	V	
I _{SUP}	Supply Current		28	35	mA	

Electrical Characteristics

Operating Conditions: V_{Sup} = 5.0 V and T_A = 25° C

Note (1): Outputs are ratiometric to the supply voltage V_{SUP}

Outputs

Analog Output Voltage Range	360ASMF1	0.5 V to 4.5V ⁽¹⁾	0 to 360 deg-See output plot (p3)
	360ASMF2	0.5 V to 4.5V ⁽¹⁾	0 to 30 deg-See output plot (p3)
	360ASMF3	0.5 V to 4.5V ⁽¹⁾	0 to 90 deg-See output plot (p3)
	360ASMF4	2.5 V ± 2.0V ⁽¹⁾	0 ± 90 deg-See output plot (p3)
	All models	≤ 50mV	When magnet out of range
Analog output current	All models	± 1mA max	

Inputs

Zero Angle Set	Activate Level	>4.75 V prior to V _{SUP} application	Maintain for >100 ms Max voltage not to exceed 6V
“Zero Angle Set” output level	360ASMF1,2,3	0.50 V±0.01 V ⁽¹⁾	
	360ASMF4	2.50 V±0.01 V ⁽¹⁾	
Response time	≈ 17 ms	Time required to sample inputs and update output	
Resolution	10 bits		
Accuracy	360ASMF1	± 1 deg	
	360ASMF2	± 0.1 deg	
	360ASMF3	± 0.25 deg	
	360ASMF4	± 0.5 deg	

Magnetic Specifications

Max horizontal field	50 mT (500G)	At surface of module
Min horizontal field	6 mT (60G)	Below 6 mT, Magnet “Out of Range” will be activated

Revision Date 07 May, 2007, 360ASMF

Europe: Senis GmbH: Technoparkstrasse 1, 8005 Zurich, Switzerland. www.senis.ch. +41 (79) 366-8756
The Americas: GMW Associates: 955 Industrial Road, San Carlos, CA 94070, USA. www.gmw.com. +1 (650) 802-8292

FUNCTIONAL OPERATION

Zero Angle Set command - The electrical output of the module for the zero angle position can be set to match any mechanical position of the magnet within the 360 degree rotation. This feature eliminates the need to mechanically align the position of the sensor output to the mechanical position of the rotating target. The Zero Angle Set function is initiated by providing a momentary connection between the Analog Output lead and the 5V supply lead prior to applying power to the module. Once power is on for more than 100 ms, the momentary connection is removed and a 100 ms “Zero Angle” calculation is initiated. At the end of the 100 ms time, the 360ASMF is operational and the Analog Output will be set to 0.5V for the 360ASMF1, 2 & 3 modules and to 2.5V for the 360ASMF4. The Zero Angle Set point is permanently stored into flash memory and remains there until a new Zero Angle Set command is initiated. The maximum number of changes to this set point is 50,000

Caution:

The output lead must not be exposed to voltages larger than the maximum specified voltage of 6.0V or damage to the module may occur

Magnet “Out of Range” Fault Detection- When the magnetic field strength at the surface of the module drops to approximately 6 mT. The Analog output voltage will default to less than 50 mV, which is well below the 0.5V to 4.5V active range.

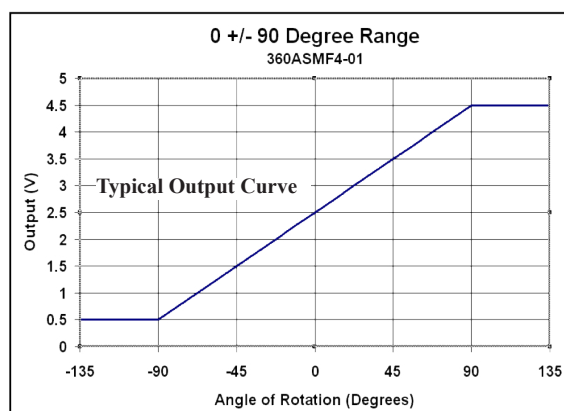
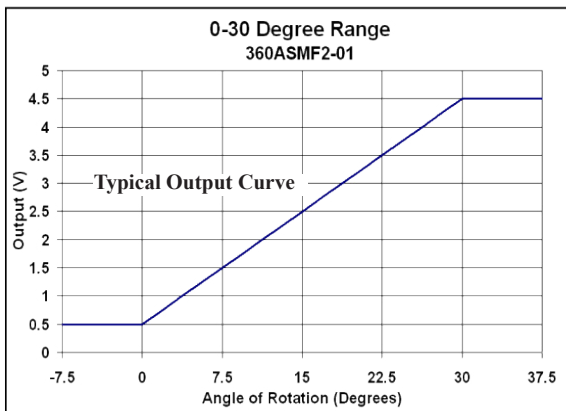
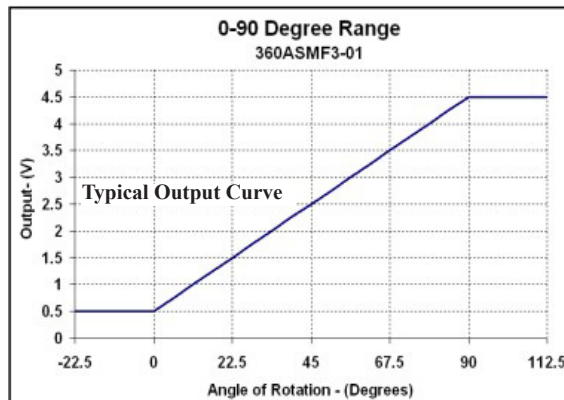
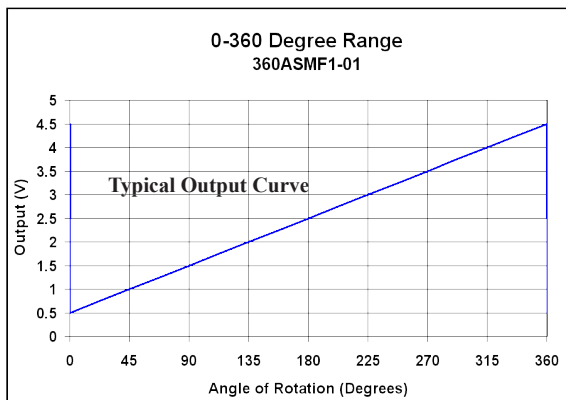

Revision Date 07 May, 2007, 360ASMF

APPLICATION HINTS

Power supply noise- The sensor's output is ratiometric with the power supply, therefore any noise on the supply will be transferred to the output signal. The 360ASMF incorporates some internal filtering, however it is best to keep the supply voltage clean of noise and transients.

Output Loads - For normal operation, do not connect the Analog output to an active high load. If the Analog output is held high during the power on, the "Zero Angle Set" routine may be initiated. Output load should be referenced to Common.

Magnet Targets - The Ametes 360ASMF series angle sensing modules can work with many different magnet shapes and sizes as shown in following illustrations. The module senses field vectors that are parallel with the top surface of the module. The direction of the field vector is converted to angle output as an analog voltage signal. The distance between the magnet and the surface of the module is referred to as the "Air Gap" and this distance is dependant on the size and strength of the magnet. The maximum strength of the horizontal field should not exceed 50 mT (500 Gauss) at the surface of the module nor should the field strength at the surface drop below 6 mT (60 Gauss). For example a GMW P/N 55B0082, SmCo 24 magnet, 6 mm in diameter and 4 mm thick, shown in the diagram to the right, will allow a minimum air gap of approximately 2.5 mm and a maximum air gap of approximately 6 mm.

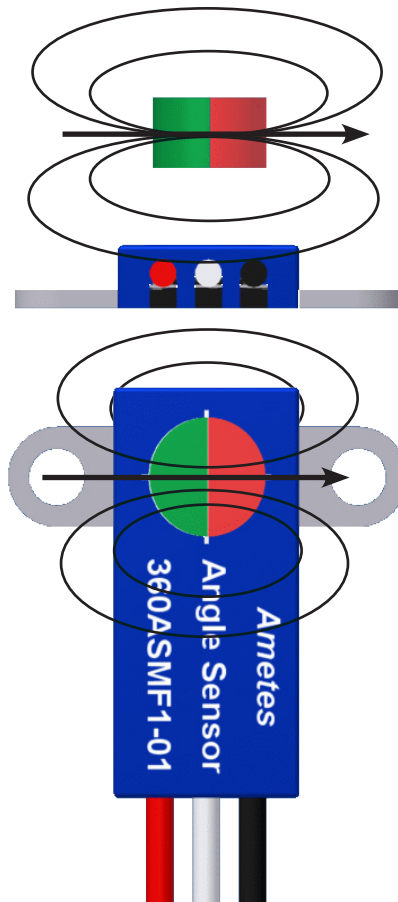

Motor Control - The Ametes 360ASMF series is not recommended for motor control or high speed applications because the response time of 17 ms is too long for most motor RPM speed requirements.

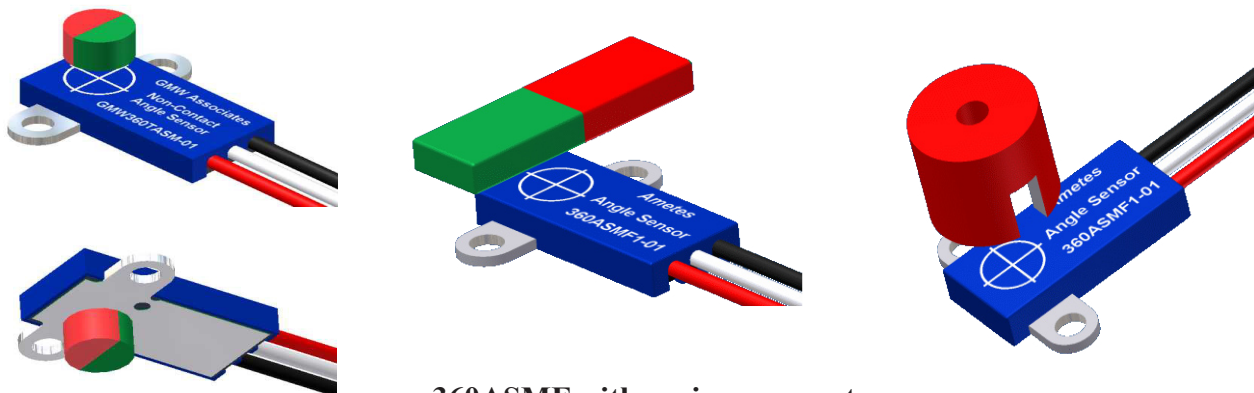

360ASMF with various magnets

Revision Date 07 May, 2007, 360ASMF