

The Model YM12-3-5-5T is a single-axis, 0.1% accuracy, high linearity, high stability magnetic field to analog voltage Transducer. It is particularly appropriate for mapping the magnetic field in the range to 5T. A novel SENIS sensor chip in the probe entirely eliminates influences from DC magnetic field components other than the one measured (Y-axis), so that even for strong non-uniform fields **no planar Hall effect** leads to errors in the output voltage. The transducer consists of two modules connected by a flexible cable C1 (see Fig.1). The magnetic field sensitive module H (Figure 2) contains a high quality Hall element. To build up a complete measurement system, connect the module E with a simple power supply and a voltmeter.

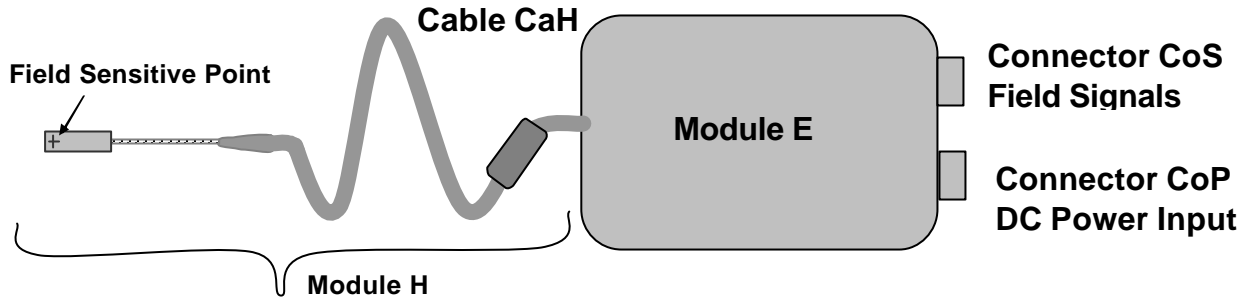

Figure 1: Structure of a SENIS high-accuracy Hall Magnetic Field Transducer

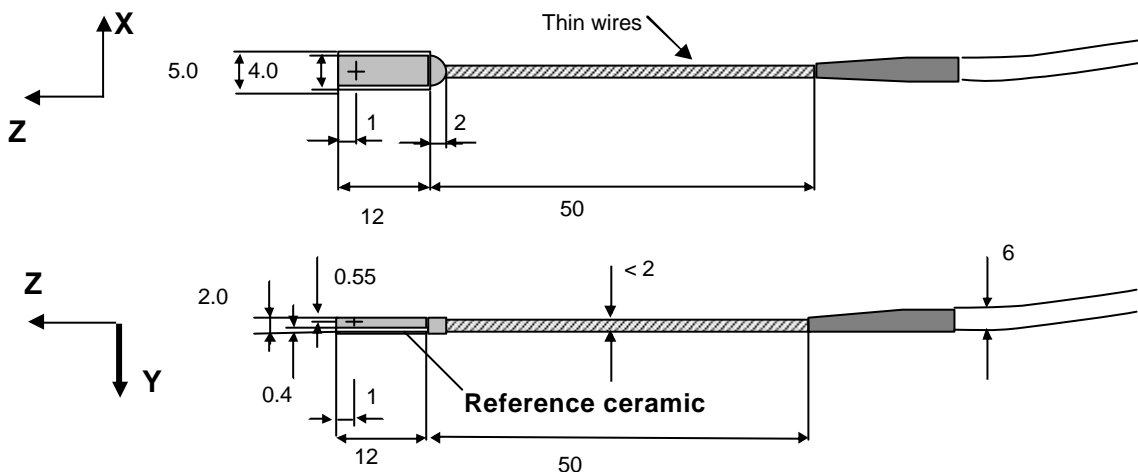

Figure 2: Probe dimensions and position of the active zone for the Single-Axis Magnetic Field Hall Transducer (module H). All measures are in millimeters.

Specifications

(Specifications are given at a nominal operating temperature (23°C) and after a warm-up time of 3 minutes.)

Output signal for channel Y:

Maximum magnetic field	± 10 T
Measurement magnetic field range	± 5 T (full scale)
Output voltage at full-scale	±10.000V, differential
Sensitivity to magnetic field	2 V/T (0.2mV/G)
Tolerances of sensitivity (B = 1T)	± 0.1 %
Non Linearity of output	(B ≤ 1T) < 0.05 %
	(B ≤ 2T) < 0.5 %
	(B ≤ 3T) < 1 %
	(B ≤ 5T) < 2 %
Long term instability	< 1 % over 10 years
Temp. coefficient of sensitivity (T= 23 ± 10°C)	< 100 ppm /°C

Offset at B = 0T	< ± 0.5 mV
Temp. coefficient of offset	< 0.1 mV/°C
Output noise and ripple (peak) 0.01..100Hz	< 0.05 mV (0.1 G)
Output resistance	< 10 Ohm, short circuit proof

Frequency response

Typical frequency response (1% error)	>1kHz
Typical Bandwidth (-3dB)	5kHz

Environmental

Temperature (operating)	10° to 50°C
(storage)	-20° to 85°C
Electromagnetic	see EMC-Test conditions
RF conducted disturbances	IEC/EN 61000-4-6, ENV 50141
Radiated electromagnetic field	ENV 50140
Pulse modulated electromagnetic field	ENV 50140
Electrical fast transient burst	IEC/EN 61000-4-4
Electrostatic discharge, ESD**	IEC/EN 61000-4-2 **

Mechanical

Coordinates:	X	Y	Z
Field sensitive volume (FSV)	0.125 x	0.10 x	0.125 mm ³
Sensitive Point (the center of FSV)	2.5 ,	1.45,	-1.0 mm
Angular accuracy of the axes	± 0.5° to the reference ceramic		
Probe total outside dimensions	5.0 x	2.0 x	14 mm
Probe-to-Electronics cable	permanently connected, shielded 5m standard length with ferrite sleeve		
Connector CoS	DIN KFV70, 7 pole, 60°. (Mating Plug, SV70) field signal Y+, Y- Pins 4 and 3 respectively signal common Pin 7		
Connector CoP	DIN SFV50, 5 pole. (Mating Plug, KV50) power, +12V Pin 3 power, -12V Pin 1 power common Pin 2		
Electronics module	high mechanical strength, electrically shielded aluminum case 95 W x 120 L x 37 H mm with mounting provision.		

Power

Voltage	+12V, -12V nominal, ±10%.
Current	ca. 50mA

Magnetic Induction Field (B) Units

1T = 10kG, 1μT = 10mG

Recommended accessories:

Power supply S12-5 (±12 V) 110/220V
Zero gauss chamber: ZG12
Output cable 1.5 meter: CO15

Installation manual YM12-3-5-5T Transducer

The YM12 Hall-Transducer consists of a unique very small encapsulated hall-sensor element. The probe head is build as robust as possible for a small precision device, however, it has to be handled with care. The following precautions will help not to damage the probe when installing or handling and to preserve their accurate calibration.

The probe has to be mounted with very low pressure on probe head and their thin wires. If the probe head is clamped, make sure that the surface in contact with the ceramic plate is flat and covers the whole of the ceramic plate. Don't apply more force then required to hold the probe in place. The probe cable has to be clamped nearby the probe head, so the very thin wires can't be torn away from the probe head. The thin wires of the flexible section at the probe head can be folded carefully, repeated strong flexing should be avoided.

The small probe head is shipped protected by a plexiglas tube. The tube protects the flexible section and the probe head against mechanical damage and against direct high voltage discharge.

Remove the protection tube only when there is no danger of a mechanical shock or electronic discharge.

EMC-Test conditions (The Test was only done for standard YM12-3 with 2m cables):

- The transducer YM12-3-2 was supplied with SENIS' "S12" power supply which corresponds to the directives 73/23/EEC and 89/336/EEC.
- The output cable was a SENIS' "CO15" shielded cable with ferrite RI-14-28 (25MHz , 177 ohm). The "Gnd" output contact was grounded.
- For the ESD** Test, the flexible section (thin wires) and the probe head were sheltered in the protection tube delivered with the transducer.

During the EMC test temporary degradation of the transducers function like offset drift can occur. After the EMC tests no damage or change of the sensor parameter appears, the transducer continues to operate according to its specifications.

In order to improve the operations in a electrically noisy environment, the probe head and the thin wires of the flexible section has to be mounted in a grounded metal shelter.

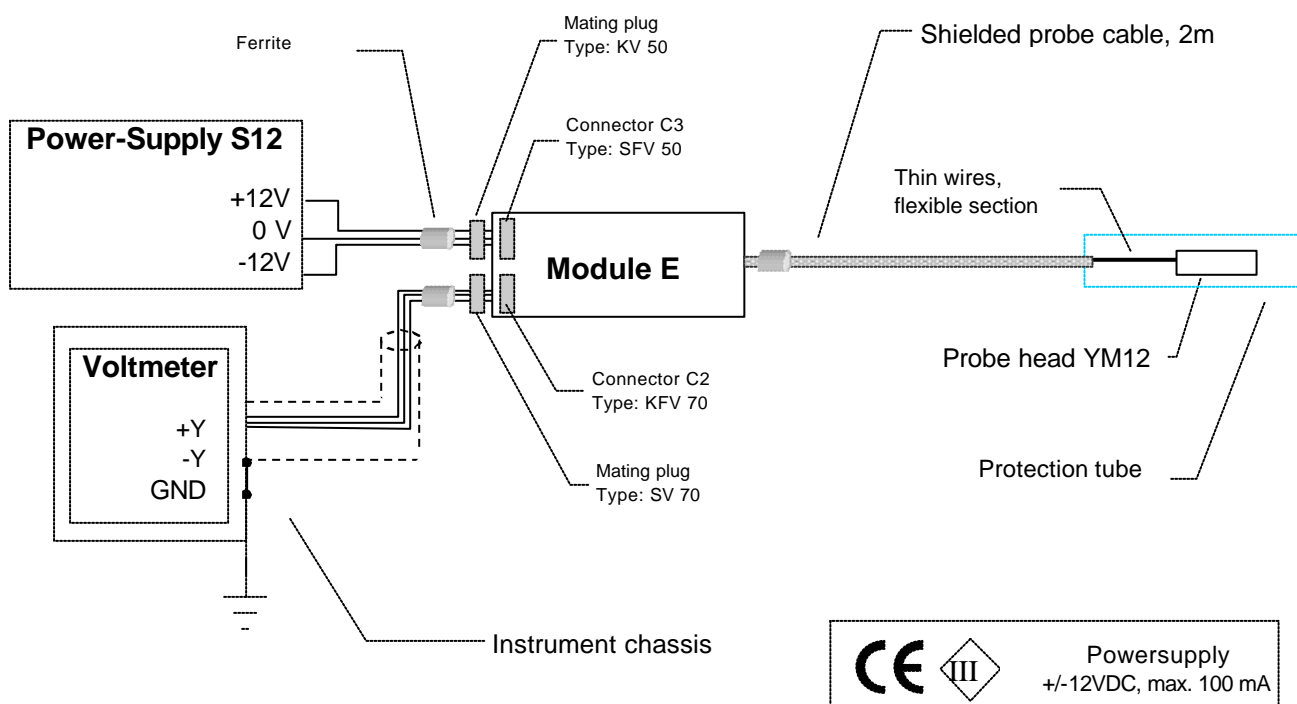

Figure 3: Set-up for all EMC-tests