

## **BARTINGTON MAG-03PSU**

### **POWER SUPPLY UNIT**

#### **OPERATION/MAINTENANCE MANUAL**

Distributed by:

GMW Associates

955 Industrial Road, San Carlos, CA 94070 USA

Tel: (650) 802-8292 Fax: (650) 802-8298

Email: [sales@gmw.com](mailto:sales@gmw.com)

website: <http://www.gmw.com>

Manufactured by:

Bartington Instruments Ltd.

10 Thorney Leys Business Park

Witney, Oxford OX8 7GE

England

Tel: 011 44 1993 706565 Fax: 011 44 1993 774813

Email: [sales@bartington.com](mailto:sales@bartington.com)

website: <http://www.bartington.com>

January 2001

## LIST OF CONTENTS

- 1 INTRODUCTION
- 2 POWER
- 3 FILTERS
- 4 BUFFERS
- 5 CABLES
- 6 ANALOG VOLTAGE MEASUREMENTS
- 7 *Mag-03*PSU WITH *Mag-03* SERIES SENSORS
- 8 BATTERY CHARGING
- 9 LOW BATTERY ALARM
- 10 ANALOG OUTPUT
- 11 TAKING MEASUREMENTS
  - 11.1 CONNECTING UP
  - 11.2 FILTER SECTION
  - 11.3 ADDITIONAL FILTERS
  - 11.4 OVERLOAD
  - 11.5 AC MEASUREMENT PRECAUTIONS
  - 11.6 ELECTROMAGNETIC COMPATIBILITY
- 12 DETAILED CIRCUIT DESCRIPTION
  - 12.1 POWER
  - 12.2 FILTERS
- 13 FAULT FINDING
  - 13.1 EQUIPMENT REQUIRED
  - 13.2 OPEN CIRCUIT CONDITIONS OR NO SUPPLY VOLTAGE
  - 13.3 SHORT CIRCUIT CONDITIONS
  - 13.4 BATTERY
- 14 SPECIFICATIONS

## LIST OF FIGURES

- FIGURE 1 *Mag-03 & Mag-03PSU SIMPLIFIED SCHEMATIC*
- FIGURE 2 *Mag-03PSU ASSEMBLY*
- FIGURE 3 *PC36 SCHEMATIC - Mag-03PSU*
- FIGURE 4 *PC36 ASSEMBLY AND FILTER SELECTION*
- FIGURE 5 *Mag-03PSU WIRING DETAILS*

### PARTS LISTS:

- PL0065 - *Mag-03PSU ASSEMBLY*
- PL0063 - *PC36 ASSEMBLY*
- PL0855 - *Mag-03PSU FRONT PANEL ASSEMBLY*
- PL0858 - *Mag-03PSU REAR PANEL ASSEMBLY*

## 1 INTRODUCTION

This manual describes the operation and maintenance of the *Mag-03*PSU power supply unit. The unit provides a battery backed power supply of  $\pm 12$  V for the *Mag-03* series of three axis fluxgate magnetic sensors. It also contains filters for the analog outputs of the sensor. The connector pin allocation details are given in section 14 SPECIFICATIONS.

## 2 POWER

The *Mag-03*PSU contains a 6 V, 1.1 Ah rechargeable battery. The battery is charged from the 240 V ac or 120 V ac mains adaptor supplied which provides a supply of 12 V dc. The battery may be charged either intermittently or continuously, with the *Mag-03* sensor switched on or off. The battery charger input to the power supply unit accepts a supply of 6 to 18 V dc and the battery is charged via a temperature compensated constant voltage charger. A low battery alarm sounds for a short period at switch-on and continuously if the battery voltage is below 5 V.

The  $\pm 12$  V supply for the *Mag-03* series of magnetic field sensors is provided from the filtered output of an isolated dc to dc converter rated at 1 W. The *Mag-03*PSU is connected to the *Mag-03* sensor through a 6 conductor cable, the screen of which is used for the 0 V power supply return (common) line. (See Figure 1)

## 3 FILTERS

A low pass and a high pass filter are included in each of the channels for the signals from the X, Y and Z axes of the sensor. The low pass filters provide a frequency response from dc to 4.5 kHz. These filter remove the high frequency noise components of the signal from the sensor.

The high pass filters have a fixed low frequency cut off at 0.1 Hz and are intended to isolate the dc or static field component so that the alternating components above this frequency can be measured or analysed. Should static field measurements be of interest these filter sections can be linked out using an internal jack. The enclosure of this unit has a two part construction and the lid can be removed to gain access to these links. Instructions on filter selection are included on the inside of the lid. (See Figure 4)

## 4 BUFFERS

After filtering, each analog signal is fed to the appropriate BNC connector via a low impedance buffer. These buffers allow long cables and low input impedance data acquisition systems to be used. The load should not be less than 1kohm resistance or greater than 200pF.

The output common return is also buffered to eliminate crosstalk due to signal currents sharing the Va common return. A high impedance ac path is also provided between the Va common and cable screen to improve ac noise performance.

## 5 CABLES

Cables can be supplied to connect any of the *Mag-03* series of sensors to the *Mag-03PSU*. Details are given in the operation manual for the sensor. The cable carries the supply voltage to the magnetic field sensor; 0 V connection is via the screen. Analog signals are returned via three conductors and the analog return is via a common conductor.

The maximum cable length of 600 metres is derived from the following considerations:

- (a) Above this length the positive supply current of 20 mA will produce a 1.5 V voltage drop which may restrict the analog output swing especially where a low voltage supply is used.
- (b) Above this length the maximum capability for capacitance loading of the magnetic field sensor output will be exceeded.

### Cable type

Cables other than those provided by Bartington Instruments should generally conform to the specifications given and a screened type is essential if low noise performance is to be achieved. An example of an alternative cable is Belden Type 9536 for use in protected conditions, e.g. ducts etc.

## 6 ANALOG VOLTAGE MEASUREMENTS

The low resistance overall cable screen is used as a power 0 V return and, in addition to the three X, Y and Z analog outputs, a separate signal common line is provided. The provision of a separate signal common line ensures that the voltage developed in the power return, due to the power supply currents, does not appear in the analog measurement. Clearly this is only possible where no electrical connection is made between the power supply and the analog output common connection at the measurement and power supply end of the cable. Connection of the output signals to an isolated measurement device such as a battery powered voltmeter will introduce no errors. Connection of the analog outputs to, for example, a data logger may provide a source of error if the analog input LOW is connected to the electrical mains supply. Most data loggers have differential inputs and this eliminates completely any ground-loop problems. It is important, however, when using a differential input measurement instrument to constrain the common line voltage to some small value. This is usually accomplished by providing a single ground connection at the power supply.

To obtain the full precision of the magnetic field sensor the analog outputs should be connected only to analog inputs which have an impedance greater than 10 k $\Omega$ .

## 7 *Mag-03PSU* WITH *Mag-03* SERIES SENSORS

Use of the *Mag-03PSU* power supply eliminates any problems which may be encountered in providing a suitable isolated power source. The unit also provides additional filtering of the analog signal to improve the signal to noise ratio. The high pass filter section can be selected to provide either a dc or ac response.

## **8 BATTERY CHARGING**

A 12 V dc (nominal unregulated) output mains adaptor for battery charging purposes is supplied as an accessory. Before use ensure that this is of the appropriate voltage for the local mains supply, either 110 V or 220 V/240 V ac, 60 Hz or 50 Hz. As an alternative the batteries may be charged from a vehicle dashboard 12 V connector.

The internal battery will be completely charged in around five hours when connected to the charger via the 2.1 mm socket marked "CHARGER", but may be left on charge indefinitely. Charging will occur regardless of the position of the on/off switch. It is not necessary to disconnect the charger when not in use.

## **9 LOW BATTERY ALARM**

The fully sealed lead acid rechargeable battery within the power supply will provide many years of use if regularly charged. However, should this type of battery ever become completely discharged for an extended period of time its capacity will be severely reduced. For this reason a low battery alarm is incorporated in the unit. Should the batteries reach a low state of charge, with the power supply on, an audible alarm will be heard to sound continuously in which case the battery should be recharged immediately.

The low battery alarm will sound for a short time when the power supply is switched on to confirm that power is available and that the alarm operates. If the alarm fails to sound at switch on then the battery may be completely discharged.

## **10 ANALOG OUTPUT**

The analog output should not be loaded by an impedance of less than 10 k $\Omega$  or 200 pF. Connection should be via BNC coaxial cables of not more than 2 metres length. If the analog outputs are to be connected to a differential input then ensure that the common mode range of the input is constrained to within a few volts of the system ground to which the magnetic field sensor is to be connected. This may usually be done by establishing a connection between the output LOW or BNC outer connection and the system ground.

## **11 TAKING MEASUREMENTS**

### **11.1 CONNECTING UP**

Connection between the magnetic field sensor and the power supply should not be made or broken with the power supply switched on as this could cause damage to the magnetic field sensor.

### **11.2 FILTER SELECTION**

The power supply contains a filter section for each channel. The low pass filter is always connected to remove unwanted high frequency components from the signal and the high pass can

be selected if it is required to block the static background field and provide only an ac response. The decision to use either a dc or ac response will depend upon several factors.

- (a) The need or otherwise to measure the static field.
- (b) The dynamic range of any associated measuring instrument.

If the analog signal is converted by a 16 bit A-D converter, this will have a resolution of  $\pm 1$  in  $\pm 32768$ . This is just about sufficient to digitise a terrestrial field strength of  $47\mu\text{T}$  to the full resolution of the magnetic field sensor. Many 16 bit converters do not guarantee full monotonicity over 16 bits.

If only the alternating component of the magnetic field is of interest the static component can be rejected by including the high pass filter. To do this, remove the two dome head screws in the base of the power supply unit and remove the lid. This will reveal the filters. A diagram on the inside of the lid of the power supply unit shows how the filters can be individually linked for dc or ac response. (See Figure 4)

As supplied, the high pass filter is linked out and the filter section has a dc response.

### 11.3 ADDITIONAL FILTERS

The output from the *Mag-03* sensor will contain noise over a wide frequency band, including break-through from the operating frequency of the sensors at 15.625 kHz. To achieve the lowest output noise level the bandwidth should be limited, using an external filter with a sharp cut-off, to the frequency band of interest.

### 11.4 OVERLOAD

Exposure of the magnetic field sensor to a flux between +120% and +200% or -120% and -400% of the full scale range will cause the analog output to saturate. Beyond this the output will become unpredictable, usually slewing to the opposite polarity. The magnetic field sensor will not be harmed permanently due to overload but this situation should be avoided.

### 11.5 AC MEASUREMENT PRECAUTIONS

The measurement and roll-off characteristics of the magnetic field sensor ensure great precision for measurements obtained within the specified bandwidth and freedom from errors at frequencies above the -3dB point. It must be noted, however, that all fluxgate magnetic field sensors employ some form of synchronous phase detector operating at a particular frequency. This gives rise to modulation products in the presence of alternating flux close to the operating frequency. The magnitude of the products will be equal to the magnitude of the detected flux ( $\pm 3\text{dB}$ ) for a difference frequency of  $\pm 1.5\text{kHz}$ . The operating frequency of the *Mag-03* series of magnetic sensors is 31.25kHz.

### 11.6 ELECTROMAGNETIC COMPATIBILITY

The *Mag-03*PSU contains no high frequency electronics likely to cause emissions which could affect other apparatus. The constant voltage charger and lead-acid battery combined with tantalum capacitors provide good filtering to minimise any emissions. The unit is also unlikely to be affected by interference from other equipment in the normal operating environment. However,

operation close to a source of high electromagnetic fields should be avoided to prevent pick-up which will be evident as noise in the output signal.

## **12 DETAILED CIRCUIT DESCRIPTION (SEE FIGURES 1 to 5)**

### **12.1 POWER**

An unregulated voltage from the battery charger appears via the 2.1 mm charger connector between Pins 1 and 2 of PC36. Diode D1 provides protection against polarity reversal. IC1 provides a constant voltage of 6.7 V  $\pm$ 0.15 V at a maximum current of 1 A for battery charging. Diode D2 prevents discharge of the battery when a charger is not in use.

Current is supplied to the voltage regulator and alarm control IC2 via the ON/OFF switch SW1. This provides a regulated 5 V supply for the voltage converter IC3. Should the battery voltage fall below 5 V, alarm A1 will sound under the action of connection RS output of IC2. IC3 provides a nominal voltage of  $\pm$ 12 V to power the magnetic field sensor. Additional filtering is provided by the pi network comprising C5, L1, C6 and C7, L2, C8.

The power return is via the cable screen to Pin 6 of PC36. The power return contains a significant dc offset error due to circulating current. For this reason the analog signal return is via a separate conductor appearing on Pin 11 of PC36. The analog return is shared by X, Y and Z channels. To prevent dc crosstalk the common return is buffered via an operation amplifier which is one quarter of the quad Op Amp IC4. Capacitors C16 and C15 provide a boot strapped high impedance ac connection to the low ac impedance cable screen.

### **12.2 FILTERS**

Each analog channel X, Y and Z is connected to its respective buffered output via a high and low pass filter. Each filter is a single section RC network providing -6dB per octave roll-off beyond the -3dB cut off point. The 4.5 kHz low pass filter provides filtering of HF noise components and precedes the 0.1Hz dc isolation high pass filter. The series capacitor of the high pass filter may be short circuited by a link to provide a dc response.

## **13 FAULT FINDING**

### **13.1 EQUIPMENT REQUIRED**

The following test equipment will be required:-

- (i) A 3½ digit multimeter (DMM) preferably with a continuity tester.
- (ii) A cross head screw driver - medium size.
- (iii) 6.8ohm 10W resistor.

If a fault is suspected in the magnetic field sensor or magnetic field sensor/power supply combination, the following investigation of symptoms, together with fault diagnosis (i, ii, etc.) can be carried out:-

## 13.2 OPEN CIRCUIT CONDITIONS OR NO SUPPLY VOLTAGE

Ensure that power is supplied to the magnetic field sensor. Remove the cover of the *Mag-03PSU* power supply unit and establish that a voltage of  $\pm 12$  to  $\pm 13$  V is obtained on Pins 5 and 7 respectively relative to pin 6 on PC36 with the unit switched on. If the supply voltage exists then complete the following tests. If not go to Section 13.4

- (i) If the cable is suspected then the power should be switched off, the cable removed and a continuity tester used to discover any breaks in the cable conductors.
- (ii) If no breaks are discovered then the magnetic field sensor module should be suspected and returned for replacement or repair.

## 13.3 SHORT CIRCUIT CONDITIONS

If the *Mag-03PSU* power supply is connected to a magnetic field sensor, excessive current drain will be indicated by overheating of IC2.

- (i) To eliminate the magnetic field sensor, switch off and disconnect it then switch on and see if the condition persists.
- (ii) To eliminate the cable, disconnect it and see if the condition persists.
- (iii) If the condition still exists then the voltage converting and filtering circuitry should be suspected.
- (iv) If the cable is suspected, use a continuity tester to check for short circuits.
- (v) If the magnetic field sensor is suspected, please return it for repair.
- (vi) If the circuitry within the power supply is suspected, further tests using the DMM may be carried out.

## 13.4 BATTERY

**WARNING:** The battery is of the fully sealed lead acid type and can deliver current in excess of 40 A. Do not under any circumstances short circuit the battery.

Suspect charger

If the power supply unit does not produce a  $\pm 12$  to  $\pm 13$  V supply check that the battery is fully charged. If it is then the voltage converter IC3 should be suspected. If the battery is not charged carry out the following tests:-

- (i) Connect the ac mains adaptor to the power supply and leave on for at least ten minutes with the *Mag-03PSU* switch in the down or OFF position. If the mains adaptor and battery charger circuitry is functioning the power supply will become slightly warm and the constant voltage regulator IC1 which is mounted on the front panel using an insulation washer will become hot (Take Care).

(ii) If it is believed that charging is not taking place connect a voltmeter across the battery. Whilst charging is taking place the battery voltage should increase to 6.7 V.

(iii) If the battery voltage is not 6.7 V remove the power supply connector and check for around 12-18 V (unregulated) between the outer and inner terminals of the connector. If this is not present then the ac adaptor is suspect and a replacement should be sought.

(iv) If the ac adaptor is believed to be working then the fault may exist in the regulator IC1 and associated circuitry.

#### Suspect battery

If the battery voltage is 6.7 V under charge but is believed not to retain a charge carry out the following test:-

Connect the 6.8ohm resistor and voltmeter simultaneously across the battery terminals. A battery in reasonably good condition should sustain a voltage of 5.8 V minimum for five seconds. For an older battery a voltage of 5.2 V minimum for five seconds should be expected. Failure to do so indicates that a replacement battery is required.

#### Replacing the battery

- (a) Remove the three M3 nuts and shakeproof washers which retain PC36.
- (b) Separate the front and rear panels of the power supply unit (Do not disconnect any wires).
- (c) Disconnect the battery terminals.
- (d) Prise the battery away from the base plate to which it is retained by two small pieces of double sided adhesive tape.
- (e) Obtain a new part and install in the reverse order. Strictly observe that the positive terminal with the red wire is connected to the switch and the negative terminal with the black wire is connected to PC36.

## 14 SPECIFICATIONS

### Mechanical

- Materials* : high strength ABS
- Dimensions* : 133mm x 84mm x 46mm

### Electrical

- Sensor analog input and power output* : 10 pole Hirose plug type RM15TRD-1OP
- Outputs* : 3 BNC connectors
- Sensor power supply* :  $\pm 12$  V at 1 W
- Battery* : PANASONIC type LCR6V1.3P  
6 V 1.3 Ah Sealed lead/acid - provides up to 10 hours continuous use depending on condition and state of charge of batteries.  
(Alternative YUASA NP 1.2-6)
- Battery alarm* : sounds when battery voltage less than 5 V and at switch on
- Internal charger* : temperature compensated constant voltage type - charges battery in five hours. Continuous use is permitted.
- Battery charger input* : via 2.1 mm dc socket  
voltage 6-18 V  
current 500 mA max.

The pin allocation for the 10 way Hirose connector to the sensor is as follows:

PIN	SIGNAL
1	X out
2	Y out
3	Z out
4	signal/power ground
5	signal/power ground
6	+12 V supply
7	-12 V supply
8,9,10	no connection

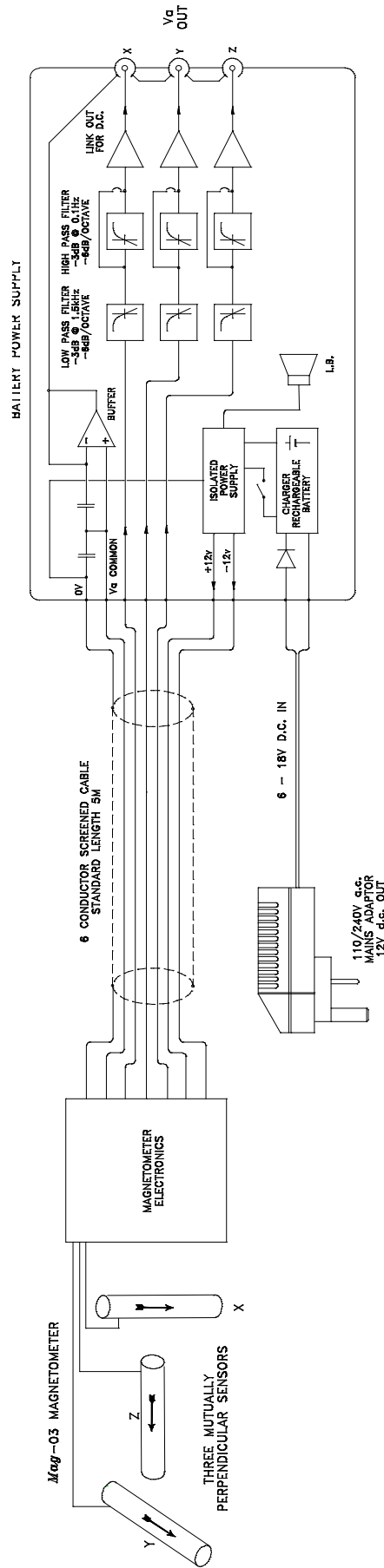

Mag-03 & Mag-03PSU SIMPLIFIED SCHEMATIC

FIGURE 1

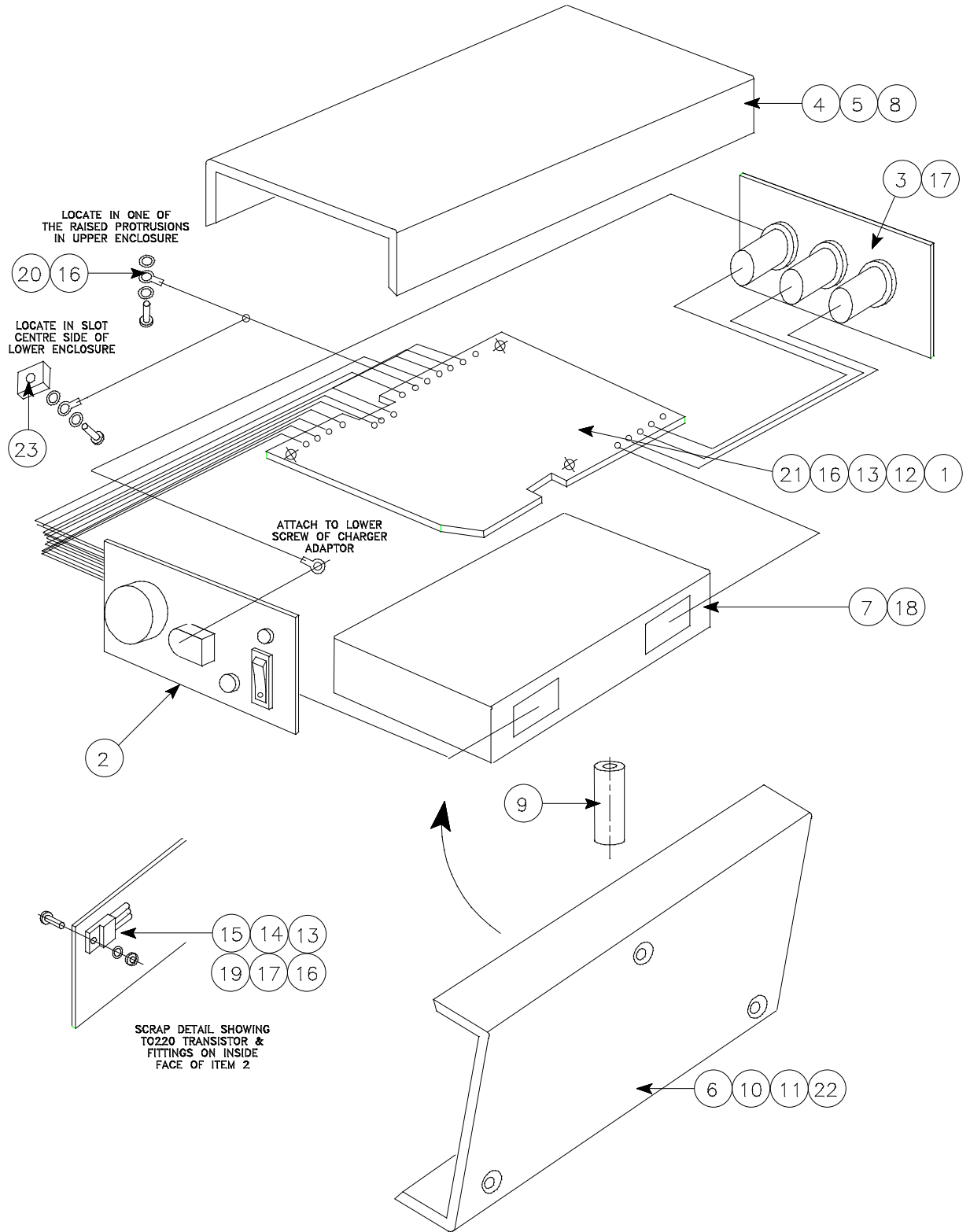

Mag-03PSU ASSEMBLY

FIGURE 2

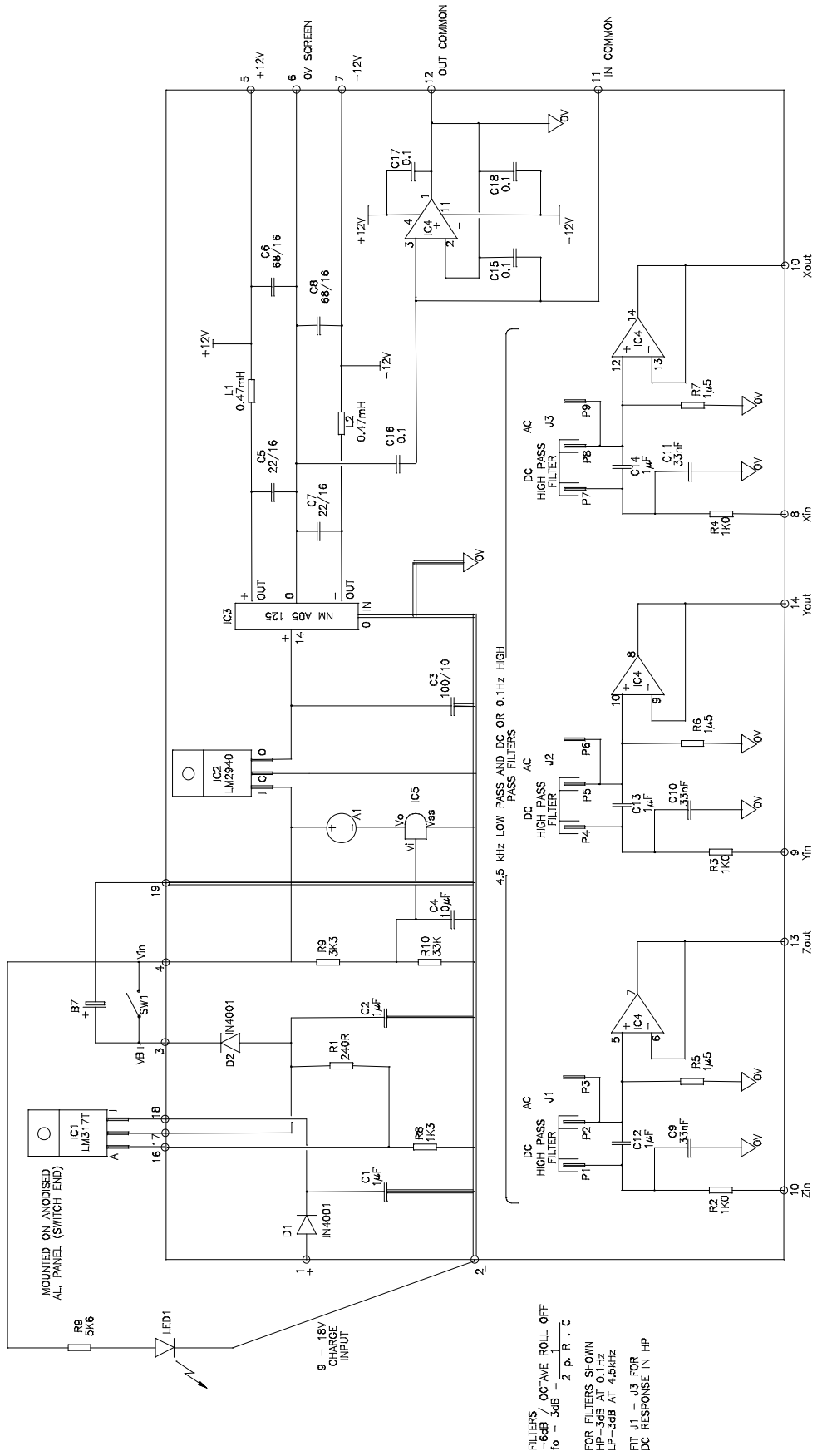

PC36 SCHEMATIC

FIGURE 3

SELECTION OF HIGH PASS  
FILTER RESPONSE

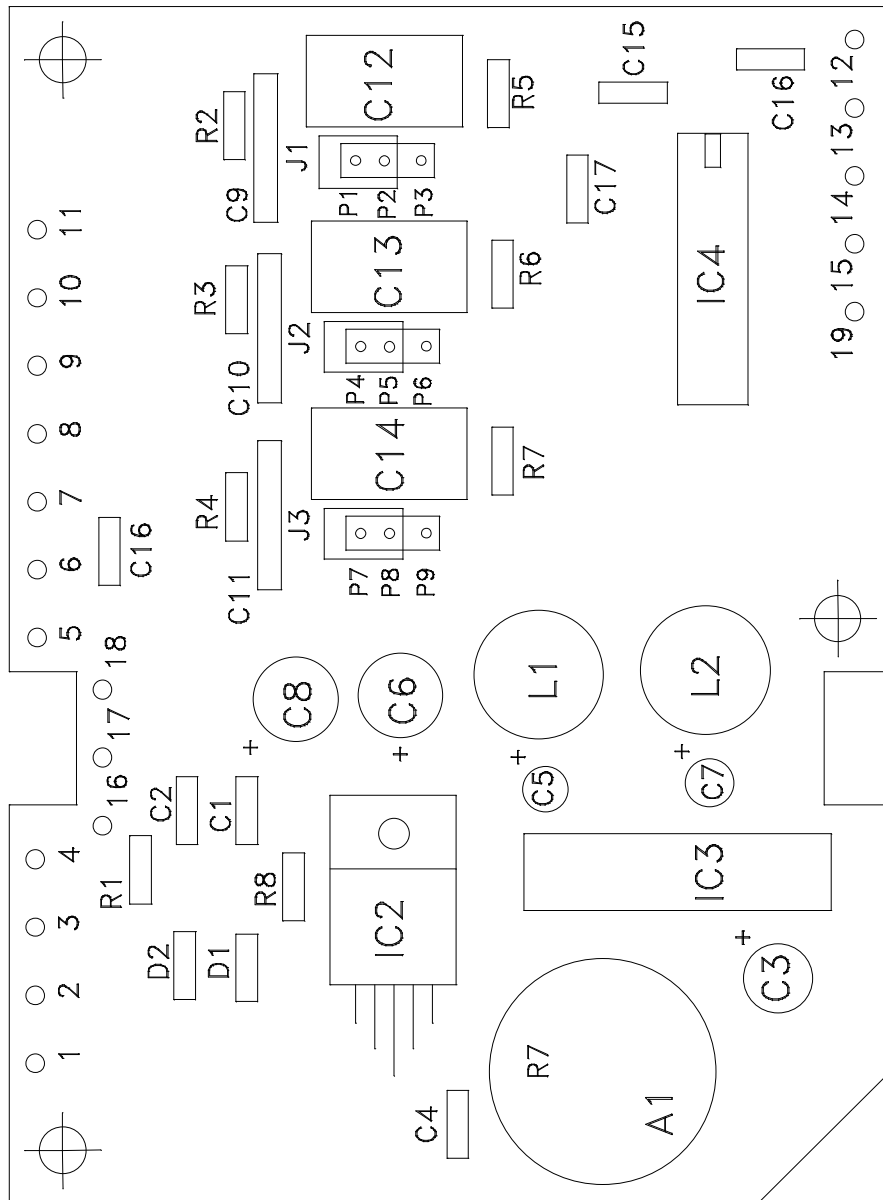
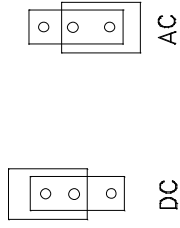

PC36 ASSEMBLY & FILTER SELECTION

FIGURE 4

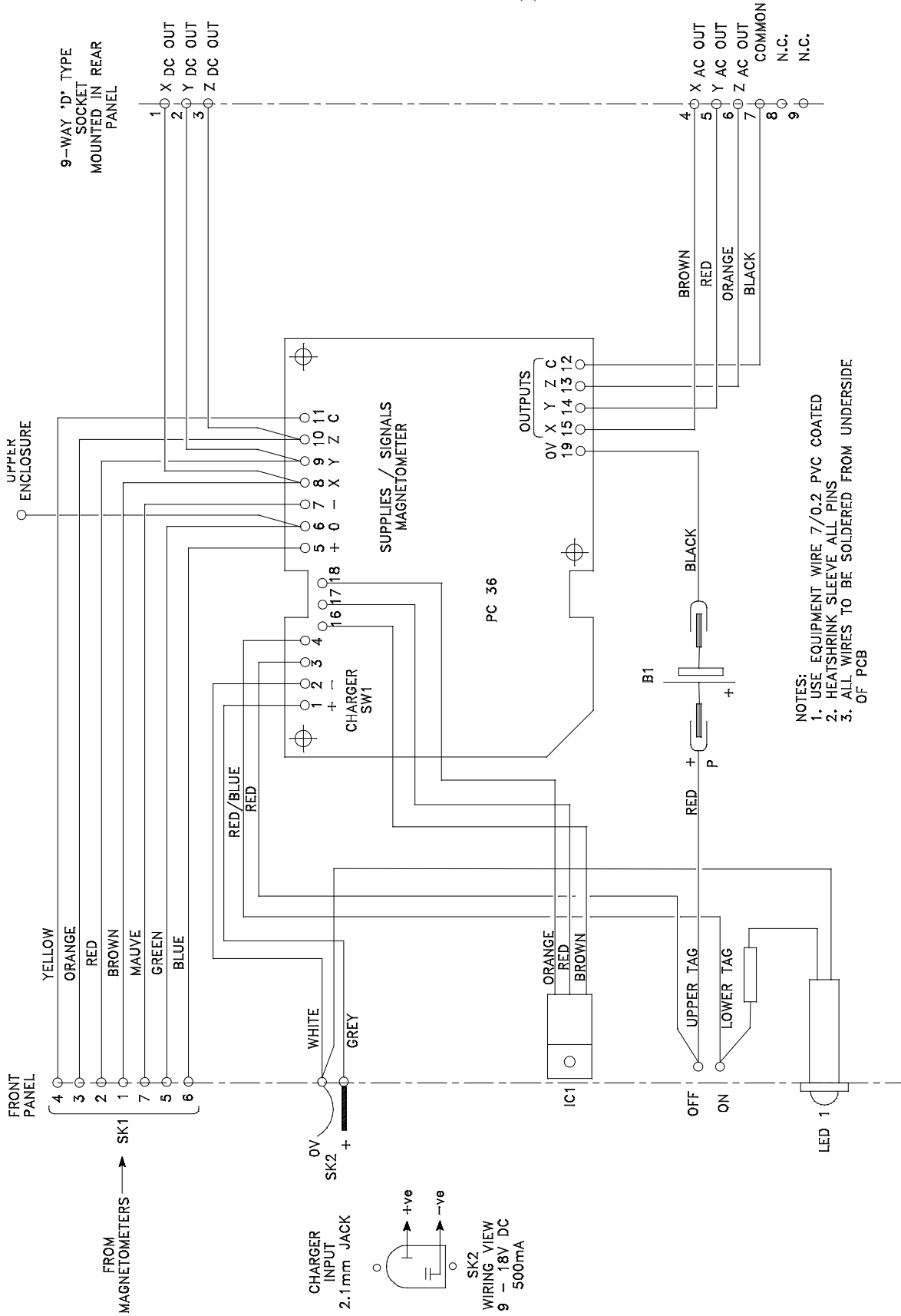

Mag-03PSU WIRING DETAILS

FIGURE 5

**PL0065/6 Mag-03PSU ASSEMBLY**

1	PC 36 ASSEMBLY		PM 0063	1
2	FRONT PANEL ASSEMBLY		PM 0855	1
3	REAR PANEL ASSEMBLY		PM 0858	1
4	LABEL	COTSWOLD SCREEN PRINTERS	DR 0067	1
5	FILTER LABEL BOND ON INSIDE OF ITEM 8	BARTINGTON INSTRUMENTS	DR 0856	1
6	ENCLOSURE LOWER HALF USE HALF SUPPLIED WITH ITEM 8		DR 0859	1
7	BATTERY PANASONIC RECHARGEABLE; SEALED LEAD ACID		LC-R061R3PG	1
8	ENCLOSURE UPPER HALF	PRACTICAL POWER	CM3-150-G-RFI	1
9	PILLAR 3 X 26mm	HAWNT	NPB-26-B-M3	3
10	DOUBLE SIDED TAPE 100mm LONG			1
11	M3x10mm CSK POZI SCREW STEEL, BRIGHT ZINC PLATED CLEAR PASSIVATED			3
12	M3 PLAIN STEEL WASHER STEEL, BRIGHT ZINC PLATED CLEAR PASSIVATED			9
13	M3 FULL NUT STEEL, BRIGHT ZINC PLATED CLEAR PASSIVATED			4
14	M3x10mm PAN POZI SCREW STEEL, BRIGHT ZINC PLATED CLEAR PASSIVATED			1
15	T0220 TRANSISTOR STYLE MOUNTING KIT			1
16	M3 SHAKEPROOF WASHER STEEL, BRIGHT ZINC PLATED CLEAR PASSIVATED			6
17	HEATSHRINK TUBING 2:1 SHRINK RATIO 1.6 X 10mm LONG BLACK			20
18	CRIMP TERMINAL FULLY INSULATED FEMALE PUSH-ON; RED 12 Amp 4.8 X 0.8mm			2

19	HEATSHRINK TUBING 2:1 SHRINK RATIO 6.4 X 20mm LONG BLACK	2
20	No. 6 SELF TAPPING SCREW 6.5mm LONG STEEL, BRIGHT ZINC PLATED CLEAR PASSIVATED	1
21	LOCTITE 7400	AS REQD
22	STICK ON FEET POLYEURETHANE SELF ADHESIVE Ø12.7 X 3.6 BLACK	4
23	FR4 NUT USED TO LOCATE GROUND IN LOWER 3THK X 9SQ. TAPPED ENCLOSURE HALF M3 X 0.5-6g THRO' CENTRE	1

## PL0063/5 PC36 ASSEMBLY

1	PCB	PC 36		PM 0061	1
2	D1,2	DIODE IN4001	FARE	IN4001	2
3	IC1	LM317T	FARE	LM317T	1
4	IC2	LM2940CT-5-0			1
5	IC3	NMA0512S	FARE	330-759	1
6	IC4	OP400GP	FARE	OP400GP	1
7	IC5	VN4302EZB VOLTAGE DETECTOR IC54 SERIES			1
8	A1	SUB-MINIATURE PIEZO AUDIBLE INDICATOR 80dB	ELECTROSPEED	264-62715G	1
9	C4	CAP: 10 $\mu$ F TANTALUM 22/16			1
10	C1,2,15,16, 17,18	CAP: 0.1 $\mu$ F CERAMIC 50V	FARE	146-232	6
11	C9,10,11	CAP: 33nF (0.033 $\mu$ F)	MAPLINS	WW35Q	3
12	C12,13,14	CAP: 1.0 $\mu$ F POLYESTER	MAPLINS	WW53H	3
13	C5,7	CAP: 22/16 TANTALUM	FARE	100-882	2
14	C6,8	CAP: 68/16 TANTALUM	FARE	100-885	2
15	C3	CAP: 100 $\mu$ F 10V TANTALUM	FARE	100-875	1
16	L1,2	0.47mH INDUCTOR	FARE	148-140	2
17	R1	RESISTOR 240R 0.5 W	FARE	333-645	1
18	R8	RESISTOR 1K3 0.5W	FARE	333-839	1
19	R2,3,4	RESISTOR 1K0 0.4W	FARE	333-803	3
20	R5,6,7	RESISTOR 1M5 1/3W	FARE	336-701	3
21	R9	RESISTOR 3K3 0.5W			1
22	R10	RESISTOR 33K 0.5W			1
23	P1 - P9	0.635mm BERG	FARE	148-194	9
24	J1 - J3	SHORTING LINKS			3
25		CABLE 7/0.2 ORANGE X 150mm			3
26		CABLE 7/0.2 RED X 150mm			4
27		CABLE 7/0.2 BROWN X 150mm			3
28		CABLE 7/0.2 RED/BLUE X 150mm LONG			1
29		CABLE 7/0.2 WHITE X 150mm			1

30	CABLE 7/0.2 GREY X 150mm	1
31	CABLE 7/0.2 YELLOW X 150mm	1
32	CABLE 7/0.2 VIOLET X 150mm	1
33	CABLE 7/0.2 GREEN X 150mm	1
34	CABLE 7/0.2 BLUE X 150mm	1
35	CABLE 7/0.2 BLACK X 150mm	2
36	CABLE 7/0.2 GREEN/YELLOW TO COMPLETE ESD SHIELD X 100mm	1
37	M3 SOLDER TAG	1
38	4.8 mm BLACK HEATSHRINK X 10mm LONG (2:1 SHRINK)	1
39	2.4mm BLACK HEATSHRINK X 10mm LONG (2:1 SHRINK)	3

**PL0855/2 Mag-03PSU FRONT PANEL ASSEMBLY**

1 FRONT PANEL MACHINED RPPE DR 0069 1

2	10-WAY PANEL JACK PLUG	FARE	147-058	1
3	2.1mm DC INLET	MAPP	FT96E	1
4	SLIMLINE ROCKER SWITCH	RSCO	197-7692	1
5	M2 X 12mm PAN POZI SCREW	RSCO	560-546	2
6	M2 PLAIN WASHER	RSCO	560-316	2
7	M2 NUT	RSCO	560-271	2
8	LED (RED) Is = 1.6mA ALGAAs	RSCO	826-492	1
9	MOUNTING BEZEL	RSCO	589-569	1
10	PTFE SLEEVING ANY (CLEAR) ALTERNATIVE ALLOWED TO COVER LED WIRES & RESISTOR	FARE	583-972	AS REQD
11	RESISTOR 5K6 1 MRS25	FARE	336-129	

**PL0858/1 Mag-03PSU REAR PANEL ASSEMBLY**

1	REAR PANEL MACHINED	RPPE	DR 0857	1
2	BNC CONNECTOR	FARE	143-777	3
3	BNC TAG WASHER ST101503	FARE	309-448	3
4	20swg COPPER WIRE X 40mm LONG	RSCO	355-063	1