



USER'S MANUAL

MODEL: 3470

45MM ELECTROMAGNET

Date Sold: _____

Serial number: _____

PROPRIETARY THIS DOCUMENT CONTAINS CONFIDENTIAL INFORMATION PROPRIETARY TO GMW ASSOCIATES. IT MUST NOT BE REPRODUCED OR DISCLOSED TO OTHERS OR USED IN ANY WAY EXCEPT FOR THE INSTALLATION, OPERATION OR MAINTENANCE OF GMW ASSOCIATES PRODUCTS.

This manual is for the model 3470 electromagnet with serial numbers 196 to 205.
For the model 3470 electromagnet with serial numbers 206 and above see manual M3470e.
For the model 3470 electromagnet with serial numbers 195 and below see manual M3470c.

TABLE OF CONTENTS

SPECIFICATIONS	Section 1
Table 1 Model 3470 General Specifications	
Table 2 Model 3470 Electrical and Water Connections	
WARNINGS [Refer to this section before operation of Electromagnet]	Section 2
INSTALLATION	Section 3
Unpacking Instructions	
Mounting Position	
Pole Selection and Installation	
Electrical Circuit	
Interlocks	
Cooling	
OPERATION	Section 4
General	
Calibration	
Field Control Operation	
MAINTENANCE	Section 5
STANDARD OPTIONS	Section 6
Probe Holder	
CUSTOM OPTIONS	Section 7
EXCITATION CURVES	Section 8
TEST DATA	Section 9
DRAWINGS	Section 10
Elmwood 3450 Thermostats	
Drawing 11801470-F 3470 Electromagnet, General Assembly (Serial numbers 196 to 205)	
Drawing 11900010 3470/PT6010 Electromagnet Electrical Assembly	
Drawing 13900130 3470/PT6010 Electromagnet Electrical Wiring	

Continued

DRAWINGS

Drawing 11900020 3470/BOP50-8 Electromagnet Electrical Assembly

Drawing 13900140 3470/BOP50-8 Electromagnet Electrical Wiring

Drawing 13900000 3470/BOP50-8 Electromagnet Electrical Wiring

Drawing 11900000 Electromagnet Assembly to Vertical Mount

Drawing 17900300 Electromagnet Vertical Mount Bracket

Drawing 18900040 Electromagnet Tool Kit

Drawing 17801500 Pole Cylindrical/Tapered (40/20mm)

Drawing 17802760 Square Pole Cap (45mm)

Drawing 18900391 Shipping Crate Assembly

Section 1
SPECIFICATIONS
Table 1. Model 3470 Specifications

Pole Diameter:	45mm (1.75 inch)
Pole Gap:	0 - 75mm (0 to 3 inch)
Standard Pole Face:	40mm (1.57 inch) cylindrical end. 20mm (0.79 inch) tapered end.
Coils (series connection)	
coil resistance (20°C)	7.3 Ohm
max resistance (hot)*	8.8 Ohm
max power (air)	3.5A/31V (0.11kW)
max power (water)	5A/44V (0.22kW)
Self Inductance	
Water Cooling (18°C)	1 liters/m (0.26 US gpm) 0.3 bar (5 psid)
Overtemperature Interlock	Elmwood 3450G thermostat part number 3450G 611-1 L50C 89/16 mounted on each coil and wired in series. Contact rating 120Vac,0.5A. Closed below 50°C.
Dimensions	Drawing 11801470 377mm W x 233mm D x 217mm H 14.8 inch W x 9.2 inch D x 8.6 inch H
Weight	27 kg (60 lb)

***CAUTION - The value of maximum coil resistance given should not be exceeded.
At this resistance the coils are at maximum safe temperature for continuous operation.**

Section 1
SPECIFICATIONS

Table 2. Model 3470 Electrical and Water Connections

DC Current (refer to Drawing 11801470)

Right hand coil terminal 2	Positive
Left hand coil terminal 1	Negative

Ground

An M4 screw (Item 20 on drawing 11801470) is provided on the magnet yoke to enable the magnet to be grounded according to local safety regulations. It is normally appropriate to connect the magnet frame to the power supply ground.

Interlocks (refer to Drawing 11801470).

The temperature interlock wiring connections are made directly onto the temperature thermostats (Item 11 on drawing 11801470).

Water (refer to Drawing 11801470).

Outlet	¼ inch OD Tube
Inlet	¼ inch OD Tube

CAUTION - Ensure that the high current connections are tight. Loose connections may lead to oxidation and overheating. The field stability may be degraded and the current terminations damaged.

Section 2

WARNINGS

REFER TO WARNINGS BELOW BEFORE OPERATING ELECTROMAGNET

1 Personnel Safety

In operation the magnet fringing field is in excess of 0.5mT (5G). This can cause malfunctioning of heart pacemakers and other medical implants. We recommend that the fringing field should be mapped and warning signs be placed outside the 0.5mT (5G) contour. Entry to this region should be restricted to qualified personnel.

2 Clamp Bolts

Before operation **always ensure that both** clamp bolts (item 6 on drawing 11801470) are firmly tightened. Ensure that the poles are arranged so that that pole gap is approximately centered between the coils.

3 Ferromagnetic Objects

During operation the magnet exerts strong magnetic attraction towards ferromagnetic objects in the near vicinity of its pole gap or coils. Loose objects can be accelerated to sufficient velocity to cause severe personnel injury or damage to the coils or precision pole faces if struck. Keep ferromagnetic tools clear!

4 Arcing

This magnet stores considerable energy in its field during operation. Do not disconnect any current lead while under load or the magnetic field energy will be discharged across the interruption causing hazardous arcing.

5 Coil Hot Resistance

Do not exceed the maximum coil hot resistance given in the specifications or coil overheating and possible damage may occur.

6 Interlocks

These should *always* be connected if the magnet is operated unattended, to avoid the possibility of coil overheating caused by excessive power dissipation or inadequate cooling.

7 Watches, Credit Cards, and Magnetic Disks

Do not move magnetically sensitive items into the close vicinity of the magnet. Even some anti-magnetic watches can be damaged when placed in close proximity to the pole gaps during operation. Credit cards, and magnetic disks are affected by magnetic fields as low as 0.5mT (5G). Depending on the previous operating field and the pole gap, the remanent field in the gap can be in excess of 50G (5mT) with the magnet power supply off or disconnected.

Section 3

INSTALLATION

Caution: This is a heavy system. All movement, lifting and installation of the 3470 Electromagnet must be under the supervision of an experienced person to prevent the possibility of serious injury or damage to the Electromagnet and associated equipment.

Unpacking Instructions and Damage Inspection

To unpack the electromagnet please use the following procedure (Refer to Drawing 18800450).

1. First remove all of the "Posidrive Screws" located at the lower edge of all the side panels of the "Crate Top Cover".
2. Gently rock the "Crate Top Cover" to work it loose from the shipping crate base.
3. Grip the side panels of the Crate Top Cover. Lift "Crate Top Cover" high enough to clear top of electromagnet, move cover to a clear area.
4. Inspect the magnet to ensure that no damage has occurred to the magnet in shipment. If damage is evident report the damage in detail to the shipper for claim and simultaneously notify GMW in case assessment of the damage must be made. If no damage is found proceed with magnet unpacking and installation.
5. Remove the M8 Hex Head Coach Bolts that secure the magnet to the shipping crate base.
6. The magnet is now prepared for final installation. Follow the appropriate procedure for direct or base mounting listed below.

Direct Mounting

1. Move magnet to final location and bolt magnet down through the four mounting holes provided in the magnet angle bracket (refer drawing 11801470)

Pole Selection and Installation (Refer to drawing 11801470).

Using the field uniformity and induction curves determine the most desirable pole; cylindrical or tapered. In general:

If a uniform field is required use a cylindrical pole end.

If a high field is required use a tapered pole end.

Pole removal (refer to drawing 11801470).

1. Turn off the power supply.
2. Loosen the two pole clamping bolts (item 6 on drawing 11801470).
3. Slide the pole out of the magnet yoke.

Section 3

INSTALLATION

Pole fitting (refer to drawing 11801470).

1. Ensure the poles and pole sleeves are clean and free from debris.
2. Reverse the pole removal sequence above.

Electrical Circuit

Never connect or remove cables from the magnet with the power supply connected. The stored energy in the magnet can cause arcing resulting in severe injury to personnel or equipment damage.

The magnet has two coils which are connected in series. (Refer to drawing 11801470). The power supply cables should be connected directly to the dc current terminals marked + and -. Recommended current cable for the 3470 is stranded copper of 1.5 mm² cross section (16 AWG).

Because the magnet stores a significant amount of energy in its magnetic field, special care should be taken to insure that the current terminations are secure and cannot work loose in operation. Local heating at the terminations can cause rapid oxidation leading to a high contact resistance and high power dissipation at the terminals. If left unattended this can cause enough local heating to damage the terminals and the coils.

The 3470 Interlocks

The Model 3470 has two thermostats, Elmwood 3450G Part Number 3450G611-1 L50C 89/16. They are located on the outer coil cooling plate and wired in series. The thermostats are normally closed, opening when the coil cooling plate temperature exceeds 50°C +/3°C.

Cooling

The Model 3470 can be operated to an average coil temperature of 70°C. Assuming an ambient laboratory temperature of 20°C and a temperature coefficient of resistivity for copper of 0.0039/°C, the hot resistance of the coil should not exceed 20% more than the ambient temperature "cold" resistance. The coil thermostat will open when either coil cooling plate temperature exceeds approximately 50°C. Clean, cool (16°C - 20°C) water at 1 l/min at 0.3 bar (5 psid) should be used to cool the 3470 magnet.

The cooling copper tubes are electrically isolated from the coils to avoid electrochemical corrosion. A 50 micron filter should be placed before the input to the magnet to trap particulates and avoid unreliable operation of the water flow switch interlock if fitted.

For continuous operation of the magnet it may be appropriate to use a recirculating chiller to reduce water and drainage costs. The chiller capacity will depend on whether cooling is required for the magnet alone or magnet and power supply. For the Model 3470 Electromagnet alone a suitable chiller is the Bay Voltex model: RRS-090.

Section 3

INSTALLATION

Cooling - continued

For recirculating cooling systems use distilled or deionized water with a biocide to prevent bacterial growth and corrosion. Do not use corrosion inhibitors in high quality electrical systems since the water conductivity is increased which can result in increased leakage currents and electrochemical corrosion.

At currents of approximately 3.50A and below the Model 3470 can be operated safely without water cooling. However the coil temperature will vary with the power dissipation. This results in dimensional changes of the magnet yoke and air cooling is not suitable when high field stability is required.

Freon, oil, ethylene glycol or other cooling mediums can be used. The flow required will be approximately inversely proportional to their specific heats. An experimental determination of the flow and pressure required will be necessary.

Avoid cooling the magnet below the dew point of the ambient air. Condensation may cause electrical shorts and corrosion.

During operation the resistance can be checked using a voltmeter across each coil. The voltage will rise to a constant value once thermal equilibrium has been reached. If it is desired to save water, the flow can be reduced until the hot resistance is approached. NOTE: This adjustment must be made slowly enough to allow for the thermal inertia of the coils.

Section 4

OPERATION

General

The magnet operates as a conventional electromagnet.

1. Adjust the poles to the desired gap with the poles approximately symmetrical about the center magnet line.
2. Adjust the cooling water flow to about 1 liters/min (0.26 USgpm) for the 3470. For operation at less than maximum power the water flow may be correspondingly reduced. Note that the inlet water temperature will determine the actual flow rate required. The above specified flow rates were determined with a water inlet temperature of approximately 18°C.
3. Turn on the power supply and increase the current until the desired field is reached.

Calibration

The induction curves may be used to estimate the field in the air gap to within four or five percent. More accurate field determination may be obtained by deriving experimentally a calibration curve for the particular pole and air gap combination being used. Magnetic hysteresis in the yoke and poles can cause an error of 30 to 70G (3 to 7mT) with an arbitrary application of such a calibration curve. This effect may be reduced to less than one percent by following a prescribed 'current setting schedule' designed to make the magnet 'forget' its prior magnetic history. The schedule should of course be used both in establishing the calibration curve and in its subsequent use. A possible schedule would be:

From zero current, increase to maximum current and reduce again to zero current. Increase again to maximum current and reduce to the current to give the desired field setting. Approaching the desired field from a higher setting will typically produce better field uniformity. This is because the field changes at the pole edges will normally lag the field change at the center thereby helping to compensate the radial decrease in field.

Greater precision in setting up the calibration curve will be achieved with the use of a digital teslameter and by making a numerical table. This table used with an interpolation routine will eliminate the error associated with reading a graph.

In any event, three points need to be remembered:

1. A calibration curve or table is only as good as the precision employed in generating it.
2. The field is defined only at the point it is measured. It will generally be different at a different point in the air gap. For example, the induction curves refer to the field on the pole axis and at the center of the air gap (median plane).

Section 4

OPERATION

Calibration - continued

3. The field is most directly a function of the current in the magnet coils. Voltage across the coils is not a good measure of field since the electrical resistance of the coils depends on the temperature (about 0.4% per degree Celsius).

Field Control Operation

The necessity to use calibration curves can be avoided by using a field controller to sense the magnetic field and provide a corresponding power supply control signal through the power supply programming inputs. Contact GMW for suitable instrumentation.

Section 5

MAINTENANCE

Periodically check that the poles are clean, properly lubricated and free of grit and dirt, which may cause binding. Be very careful not to damage the relatively soft pole surface since this may degrade the magnetic field uniformity in the gap.

Note that the surface treatments used provide good corrosion protection but in order to maintain the inherent mechanical precision of the magnet, heavy build-up of plating materials is deliberately avoided. As a result, high humidity or otherwise seriously corrosive atmospheres can cause corrosion. Periodically apply an appropriate corrosion protection, particularly when the magnet is stored for an extended period.

Check the cooling water circuit to ensure the water is clean and free of debris and bacterial growth. Ensure the in-line water filter (if fitted) is clean.

Section 6

STANDARD OPTIONS

PROPRIETARY
THIS DRAWING CONTAINS CONFIDENTIAL INFORMATION
PROPRIETARY TO GMW INC. IT MUST NOT BE
REPRODUCED OR TRANSMITTED IN ANY FORM OR
BY ANY MEANS, ELECTRONIC OR MECHANICAL,
INCLUDING PHOTOCOPYING, RECORDING, OR BY
ANY INFORMATION STORAGE AND RETRIEVAL SYSTEM,
WITHOUT THE WRITTEN PERMISSION OF GMW INC.
IN WRITING BY GMW INC.

REV	DESCRIPTION	DRAFT	DATE	APPROVED
A	RELEASE		09/11/98	G.DOUGLAS

REVISIONS

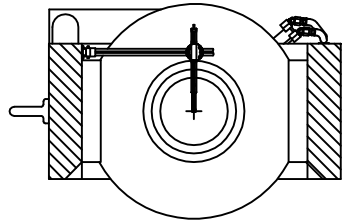

TOP/REAR INSTALLATION

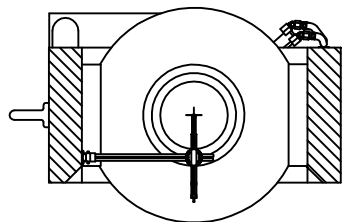

TOP/FRONT INSTALLATION

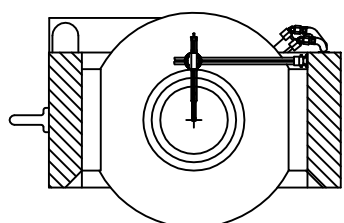

BOTTOM/REAR INSTALLATION

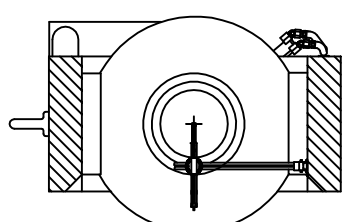

BOTTOM/FRONT INSTALLATION

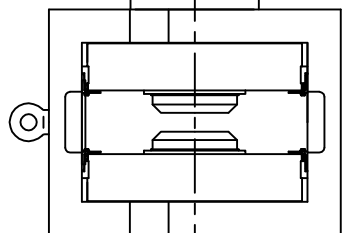

MAGNET FRONT VIEW

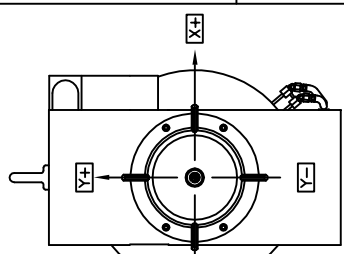

MAGNET SIDE VIEW

MAGNET MODEL	INSTALLATION POSITION	ASSEMBLY NUMBER	VERTICAL TRAVEL "Y"	HORIZONTAL TRAVEL "Z"
3474	REAR	11901251	280mm	200mm
3474	FRONT	11901252	280mm	100mm
3473	REAR	11901261	180mm	150mm
3473	FRONT	11901262	180mm	40mm
3472	REAR	11901271	130mm	100mm
3472	FRONT	11901272	130mm	30mm
5403	BOTH	11901280	130mm	100mm
3470	BOTH	11901290	130mm	100mm



MAGNET YOKE

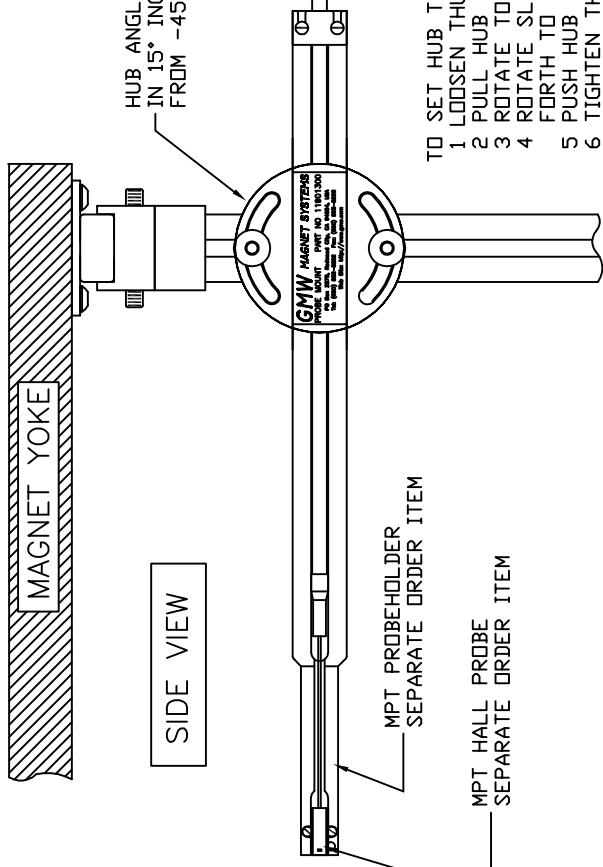

SIDE VIEW

HUB ANGLE ADJUSTABLE
IN 15° INCREMENTS
FROM -45° to +45°

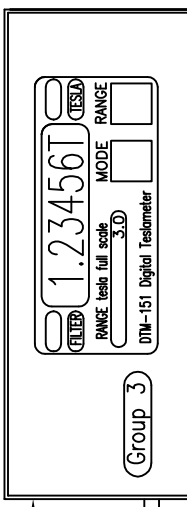

DIGITAL TESLAMETER
SEPARATE ORDER ITEM

MPT PROBEHOLDER
SEPARATE ORDER ITEM

MPT HALL PROBE
SEPARATE ORDER ITEM

- TO SET HUB TO DESIRED ANGLE
- 1 LOOSEN THUMB NUT 2mm
 - 2 PULL HUB FORWARD 2mm
 - 3 ROTATE TO ANGLE REQUIRED
 - 4 ROTATE SLIGHTLY BACK AND FORTH TO FIND INDEX PIN
 - 5 PUSH HUB REARWARDS
 - 6 TIGHTEN THUMB NUTS

ITEM	QTY	PART NUMBER	DESCRIPTION	NOTE
DRWN		DATE	DO NOT SCALE FROM DRAWING	
CHECK		DATE	DIMENSIONS & TOLERANCES (UNLESS OTHERWISE SPECIFIED)	
ENGINEERING		DATE	LINEAR INCHES/mm	
			FRACTIONAL	
			DECIMAL	
			THIRD ANGLE PROJECTION	
NEXT ASSY		SYSTEM		
SOFTWARE		AUTOCAD 13		
PARTS LIST			TITLE	
GMW			PROBE MOUNT GENERAL ASSEMBLY	
G.DOUGLAS			955 Industrial Rd, San Carlos, CA 94070	
CHECK			Tel: (650)802-8292. Fax: (650)802-8298.	
ENGINEERING			DRAWING NO. A2 11901300	
			SCALE 1:1 WT kg	
			SHEET 1 OF 1	

NOTE: ABOVE PROBE MOUNT SHOWN INSTALLED ON MODEL: 3474 ELECTROMAGNET.
OTHER CONFIGURATIONS AND MOUNTINGS ARE AVAILABLE. CONSULT TABLE FOR GMW ELECTROMAGNETS.

Section 7

CUSTOM OPTIONS

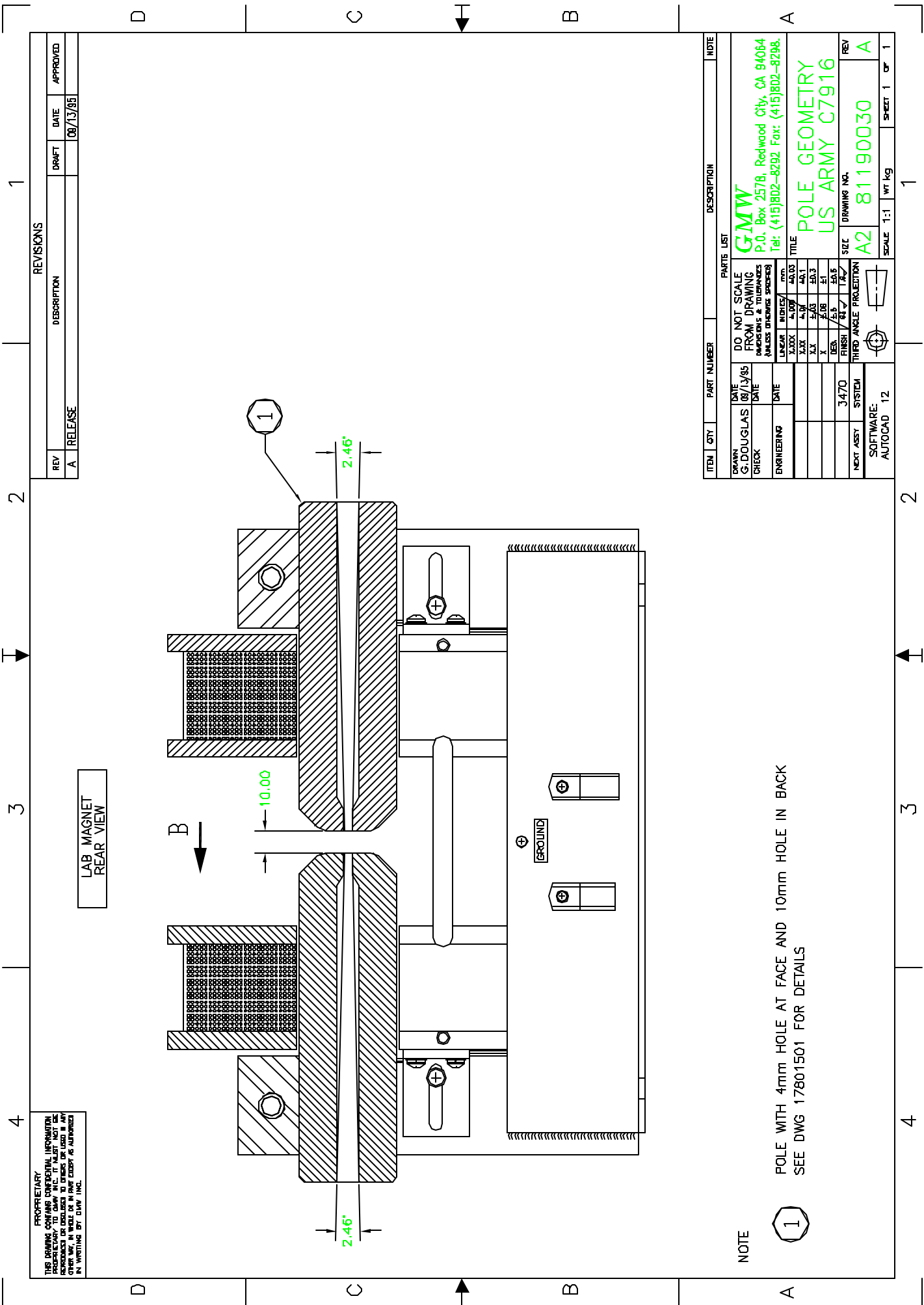

PROPRIETARY
 THIS DRAWING CONTAINS CONFIDENTIAL INFORMATION
 PROPRIETARY TO GMV INC. IT IS NOT TO BE
 REPRODUCED OR DISCLOSED TO OTHERS OR USED IN ANY
 MANNER WITHOUT THE WRITTEN PERMISSION OF GMV INC.

LAB MAGNET
 REAR VIEW

REV	DESCRIPTION	DATE	APPROVED
A	RELEASE	08/13/95	

REVISIONS

NOTE

1

POLE WITH 4mm HOLE AT FACE AND 10mm HOLE IN BACK
 SEE DWG 17801501 FOR DETAILS

ITEM	QTY	PART NUMBER	DESCRIPTION	NOTE
PARTS LIST				
DO NOT SCALE FROM DRAWING UNLESS OTHERWISE SPECIFIED				
DATE	08/13/95	DATE	08/13/95	
ENGINEERING		DATE		
LINEAR	INCHES	MM		
2:XXX	4:100	40:5		
3:XX	4:10	40:1		
X	2:5	20:1		
DES	1:1	1:1		
FINISH	1:1	1:1		
THIRD ANGLE PROJECTION				
3:470				
SYSTEM				
SOFTWARE:				
AUTOCAD	12			
DRAWING NO. A2 81190030				REV A
SCALE 1:1				WT kg
SHEET 1				OF 1

GMW
 P.O. Box 2578, Redwood City, CA 94064
 Tel: (415)802-8292 Fax: (415)802-8298

POLE GEOMETRY
 US ARMY C7916

GMW ASSOCIATES

LABORATORY ELECTROMAGNET UNIFORMITY PLOT

Model 3470
Serial No 46

Pole Face 20 mm
Pole Gap 10 mm
Hole Dia 4mm
US Army Redstone Arser

Engr Toomas Rett
Date 20 June, 1995

Magnet Current 3.5 Amps

C7916

Plot Y = 0.0 mm, Z = 0.0 mm				
X - mm	Magnet Field Tesla	X + mm	Magnet Field Tesla	Magnet Field Average Tesla
0	0.78216	0	0.78214	0.78215
-1	0.78270	1	0.78396	0.78333
-2	0.78520	2	0.78714	0.78617
-3	0.78840	3	0.78972	0.78906
-4	0.79030	4	0.79010	0.79020
-5	0.79022	5	0.78776	0.78899
-6	0.78750	6	0.78324	0.78537
-7	0.78252	7	0.77334	0.77793
-8	0.77224	8	0.75658	0.76441
-9	0.75588	9	0.73654	0.74621
-10	0.73058	10	0.70608	0.71833
0	0.78214	0	0.78184	0.78199

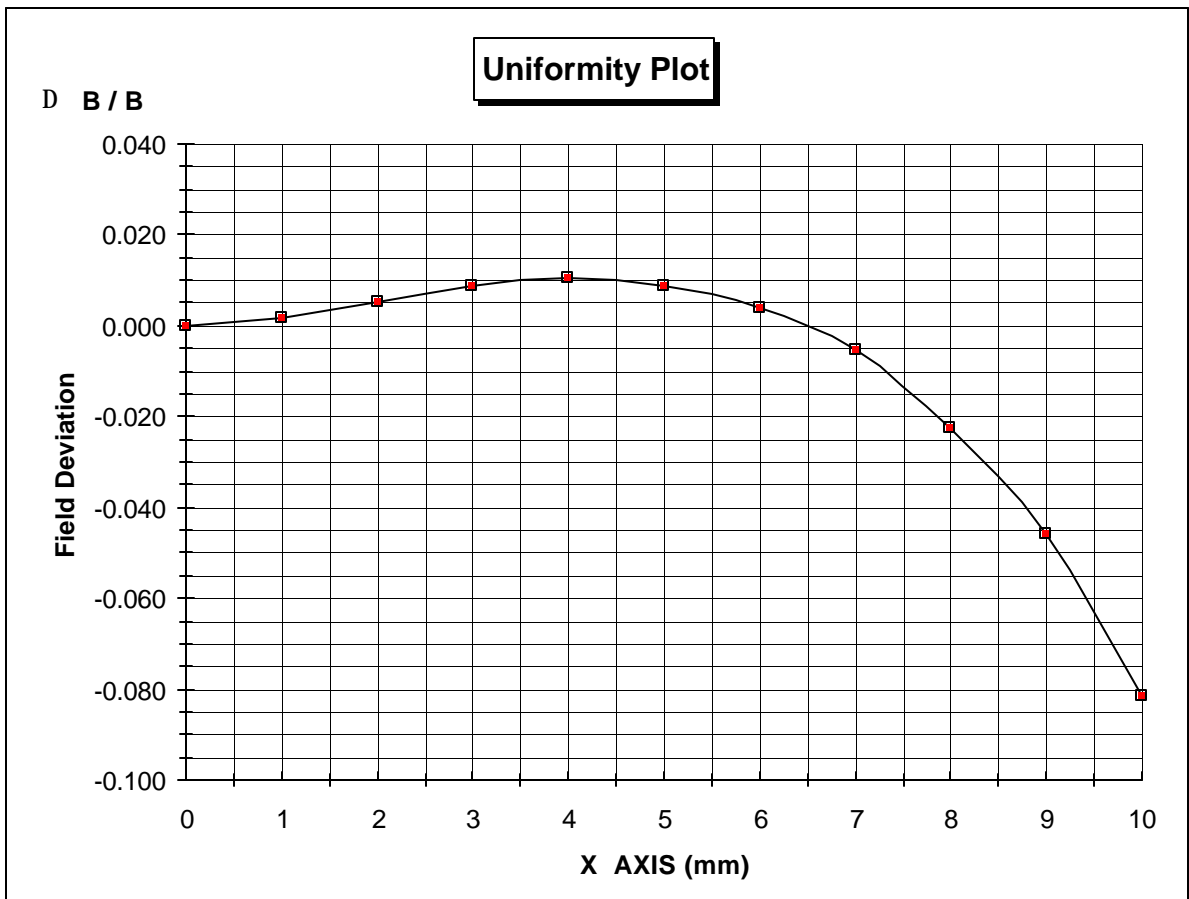

GMW ASSOCIATES

LABORATORY ELECTROMAGNET UNIFORMITY PLOT

Model 3470
 Serial No 46

Pole Face 20 mm
 Pole Gap 10 mm
 Hole Dia 4mm
 US Army Redstone Arser

Engr Toomas Rett
 Date 20 June, 1995

Magnet Current 3.5 Amps

C7916

Plot Y = 0.0 mm, Z = 0.0 mm				
X - mm	Magnet Field Tesla	X + mm	Magnet Field Tesla	Magnet Field Average Tesla
0	0.78216	0	0.78214	0.78215
-1	0.78270	1	0.78396	0.78333
-2	0.78520	2	0.78714	0.78617
-3	0.78840	3	0.78972	0.78906
-4	0.79030	4	0.79010	0.79020
-5	0.79022	5	0.78776	0.78899
-6	0.78750	6	0.78324	0.78537
-7	0.78252	7	0.77334	0.77793
-8	0.77224	8	0.75658	0.76441
-9	0.75588	9	0.73654	0.74621
-10	0.73058	10	0.70608	0.71833
0	0.78214	0	0.78184	0.78199

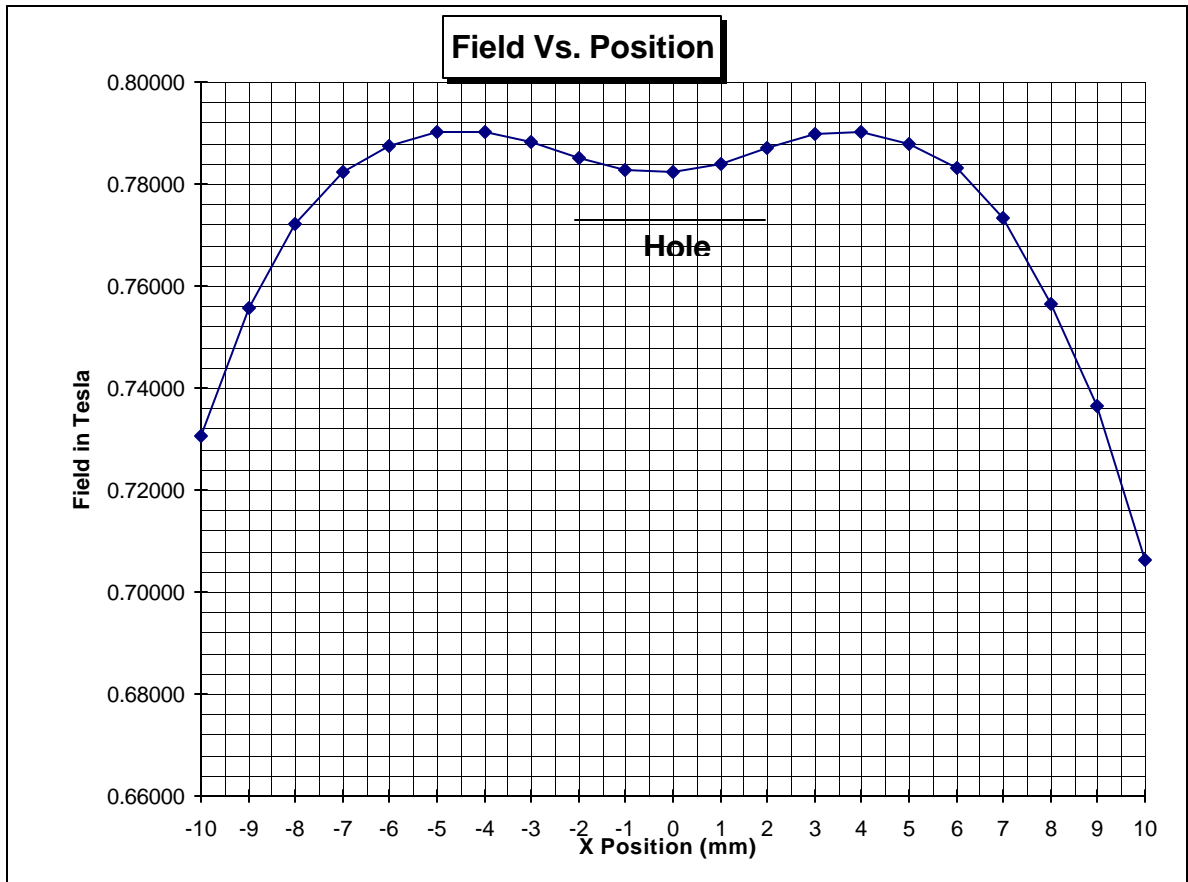

Section 8

EXCITATION CURVES

GMW Associates Electromagnet Excitation Plot Field Vs Gap

Contract No:	Page: 1 of 1	Date: Sept 22, 95
Customer:		Engr: G.Douglas
Model: 3470	Power Supply: Soren DCS 55-55	Set Current: 5.0 Amps
Serial No: 52	Serial No: D1285	Target Field:
Pole Face: As per table below	Position: X=0, Y=0, Z=0	
Serial No: None	Notes: Coil position set to minimum gap	
Pole Gap: As per table below		
Pole Spacers: None		

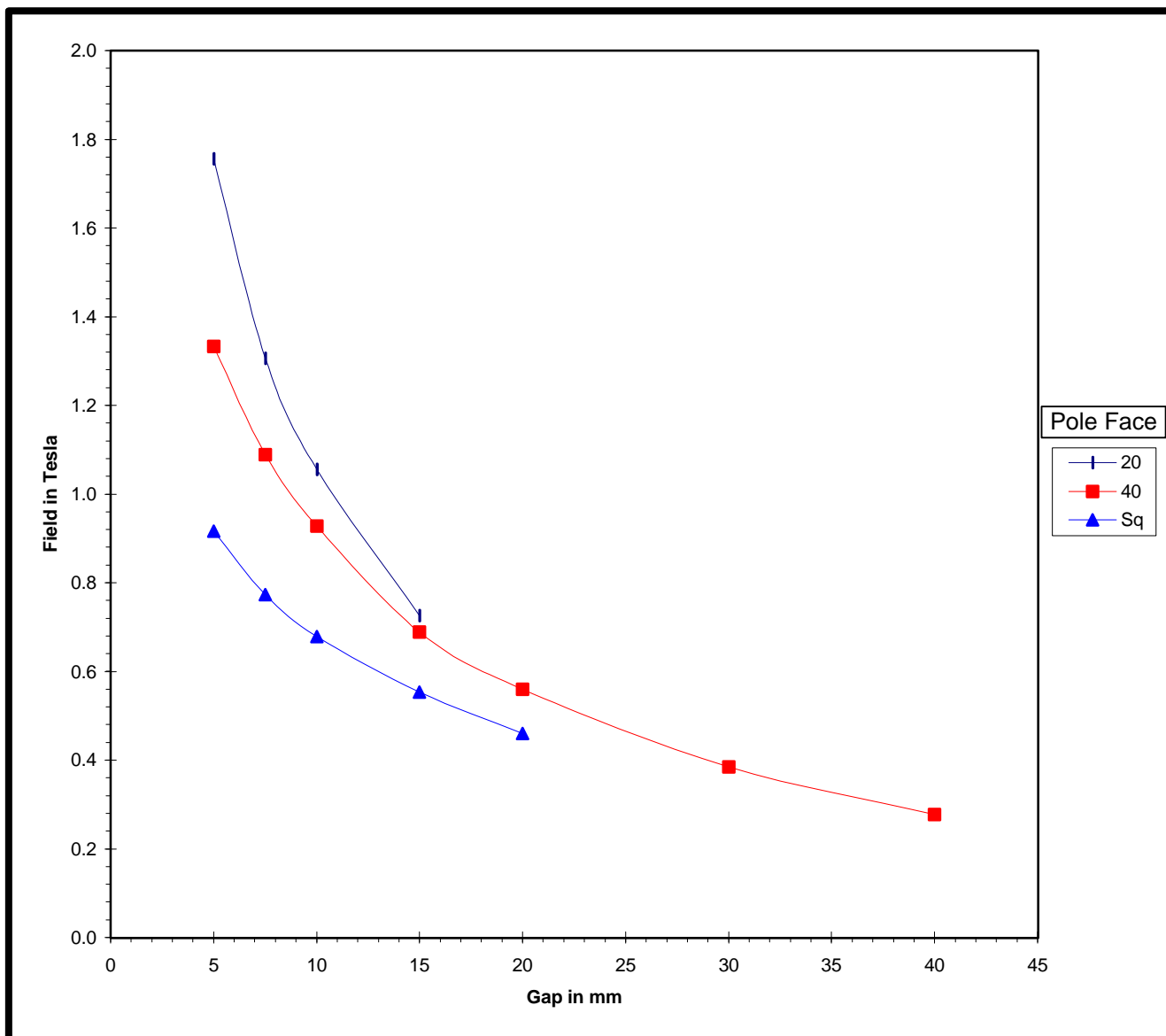

GMW Associates

Electromagnet Excitation Plot

Field Vs Current

Contract No:	Page: 1 of 3	Date: Sept 22, 95
Customer:		Engr: G.Douglas
Model: 3470	Power Supply:	Set Current:
Serial No: 52	Serial No:	Target Field:
Pole Face: 40	Position: X=0, Y=0, Z=0	
Serial No: None	Notes: Coil position set to minimum gap	
Pole Gap: As per table below		
Pole Spacers: None		

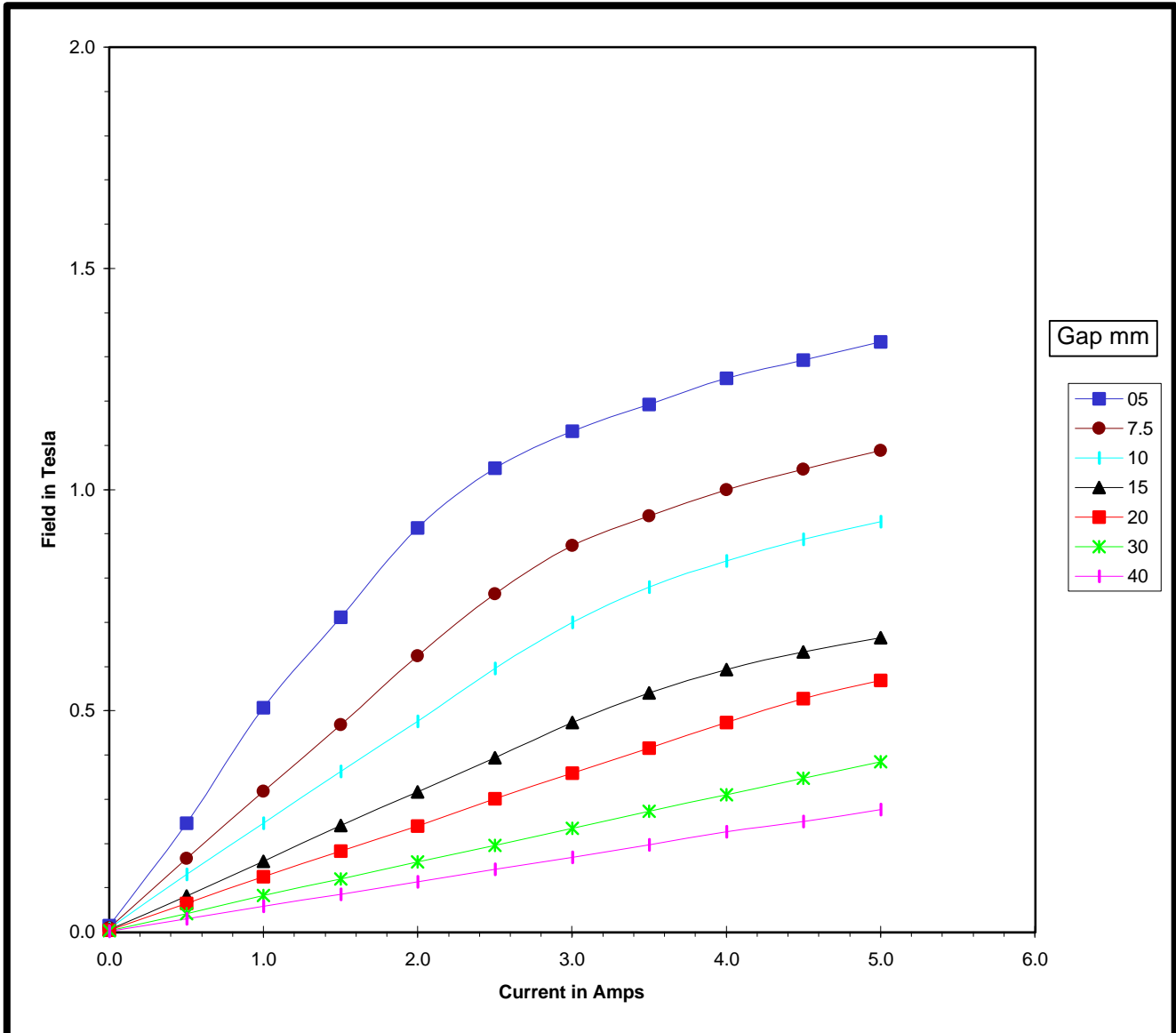

GMW Associates

Electromagnet Excitation Plot

Field Vs Current

Contract No:	Page: 2 of 3	Date: Sept 22, 95
Customer:		Engr: G.Douglas
Model: 3470	Power Supply:	Set Current:
Serial No: 52	Serial No:	Target Field:
Pole Face: 20	Position: X=0, Y=0, Z=0	
Serial No: None	Notes: Coil position set to minimum gap	
Pole Gap: As per table below		
Pole Spacers: None		

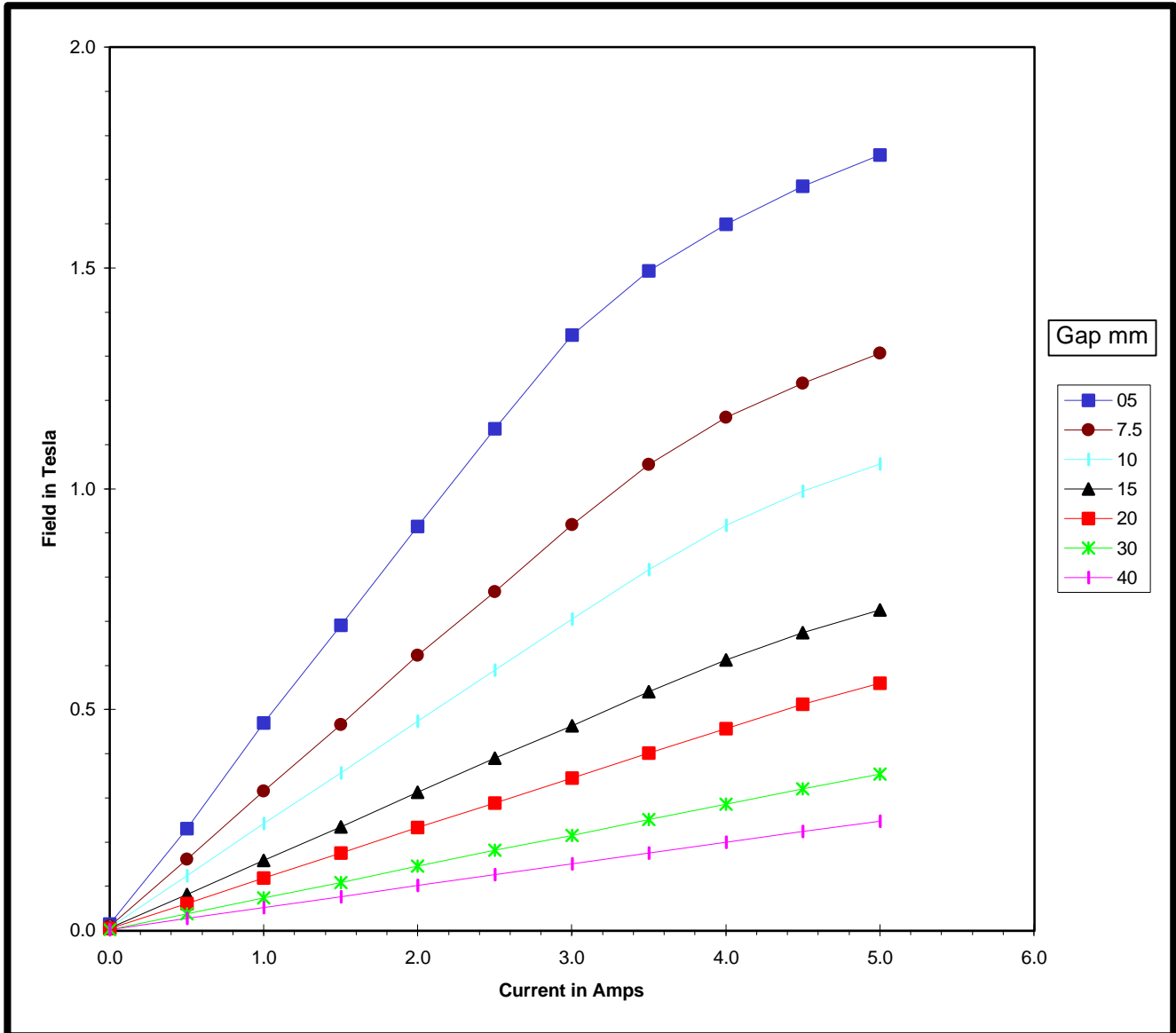

GMW Associates Electromagnet Excitation Plot Field Vs Current

Contract No:	Page: 3 of 3	Date: Sept 22, 95
Customer:		Engr: G.Douglas
Model: 3470	Power Supply:	Set Current:
Serial No: 52	Serial No:	Target Field:
Pole Face: Square	Position: X=0, Y=0, Z=0	
Serial No: None	Notes: Coil position set to minimum gap	
Pole Gap: As per table below		
Pole Spacers: None		

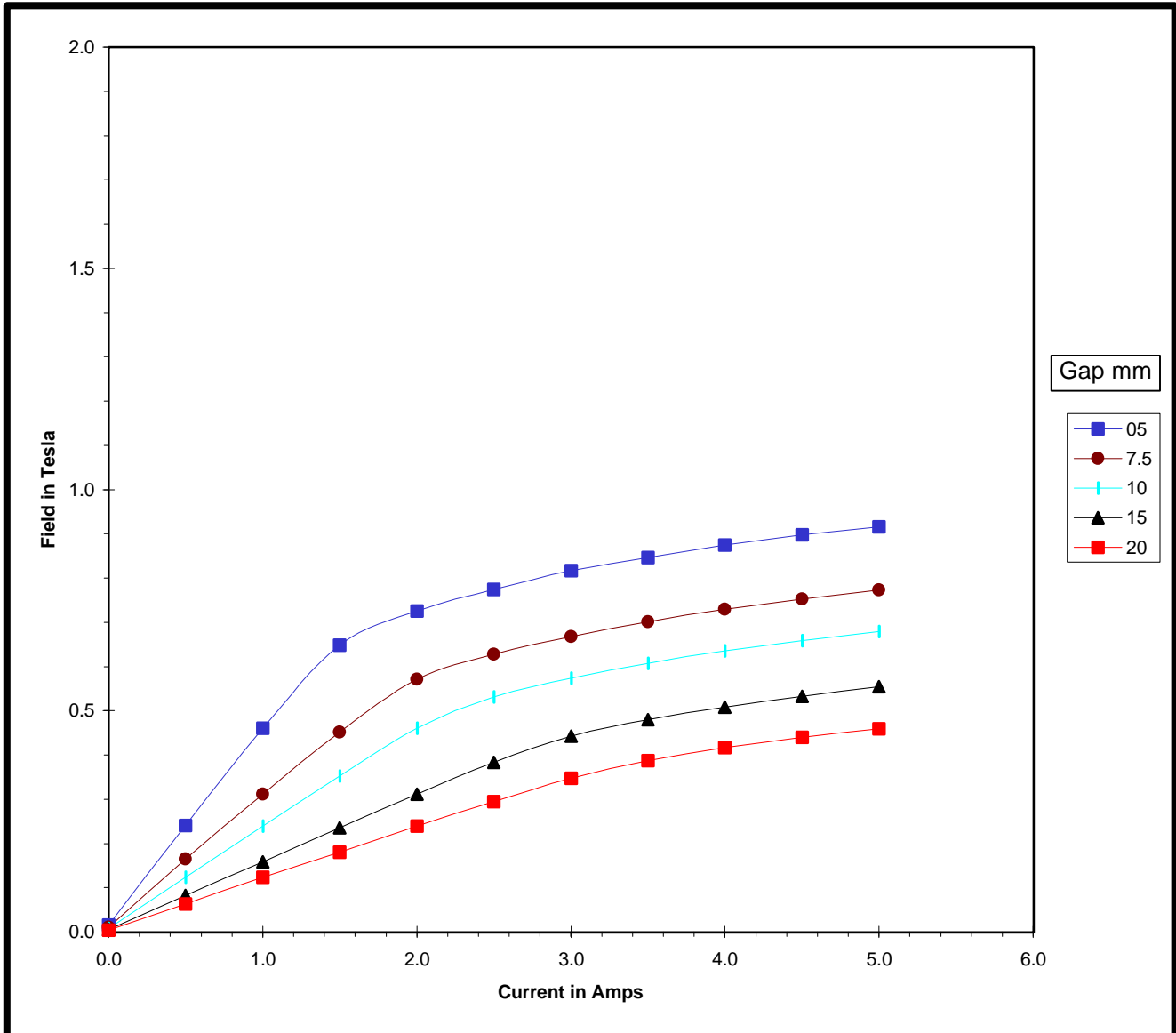

GMW Associates

Electromagnet Excitation Plot

Field Vs Current

Contract No:	Page: 1 of 3	Date:	Oct 17, 95
Customer:		Engr:	G.Douglas
Model: 3470	Power Supply:	Set Current:	
Serial No: 52	Serial No:	Target Field:	
Pole Face: 40	Position: X=0, Y=0, Z=0		
Serial No: None	Notes:		
Pole Gap: 10mm			
Pole Spacers: None			

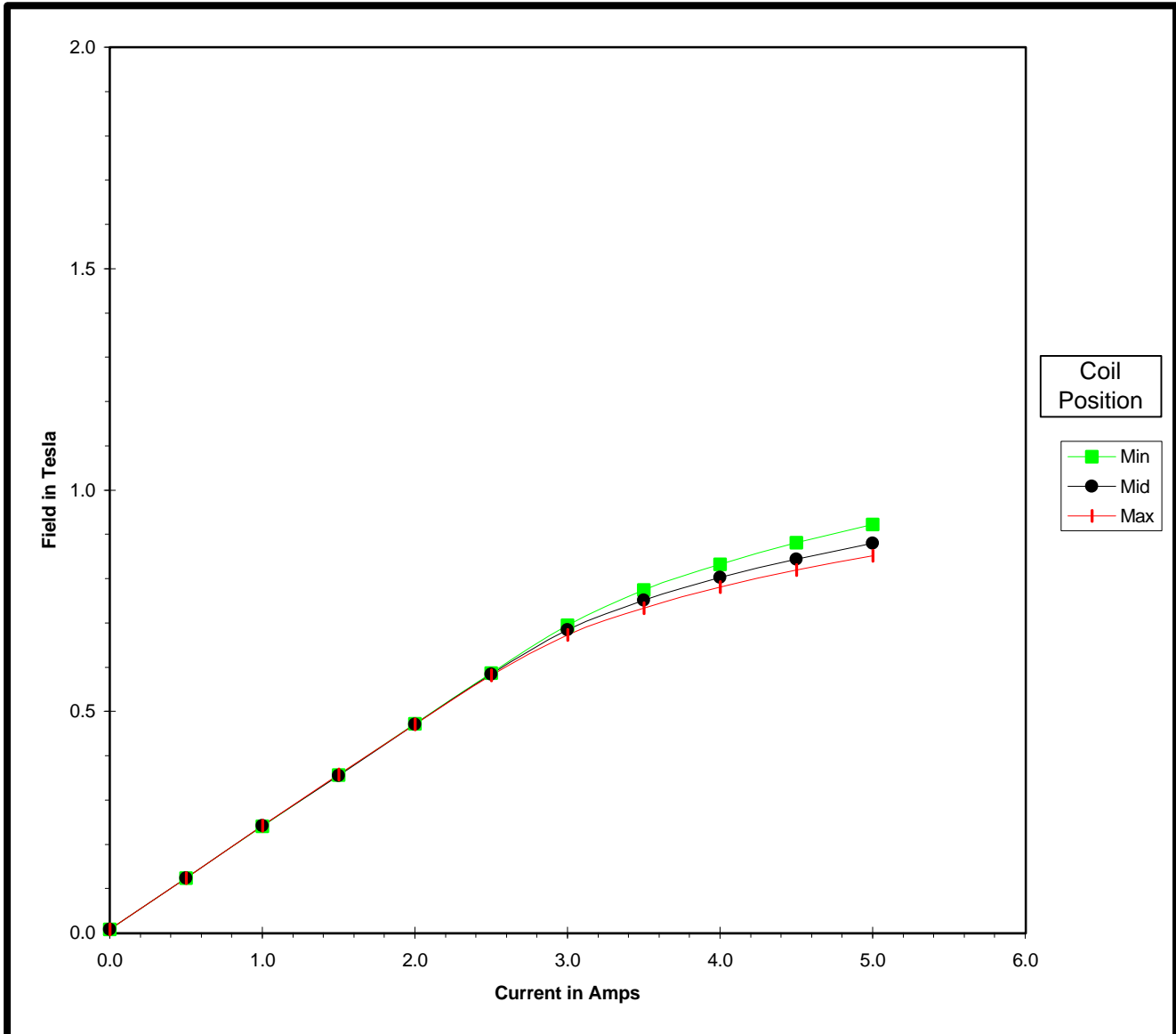

GMW Associates
Electromagnet Excitation Plot
Field Vs Current

Contract No:	Page: 2 of 3	Date:	Oct 04, 95
Customer:		Engr:	G.Douglas
Model: 3470	Power Supply:	Set Current:	
Serial No: 52	Serial No:	Target Field:	
Pole Face: 20	Position: X=0, Y=0, Z=0		
Serial No: None	Notes:		
Pole Gap: 10mm			
Pole Spacers: None			

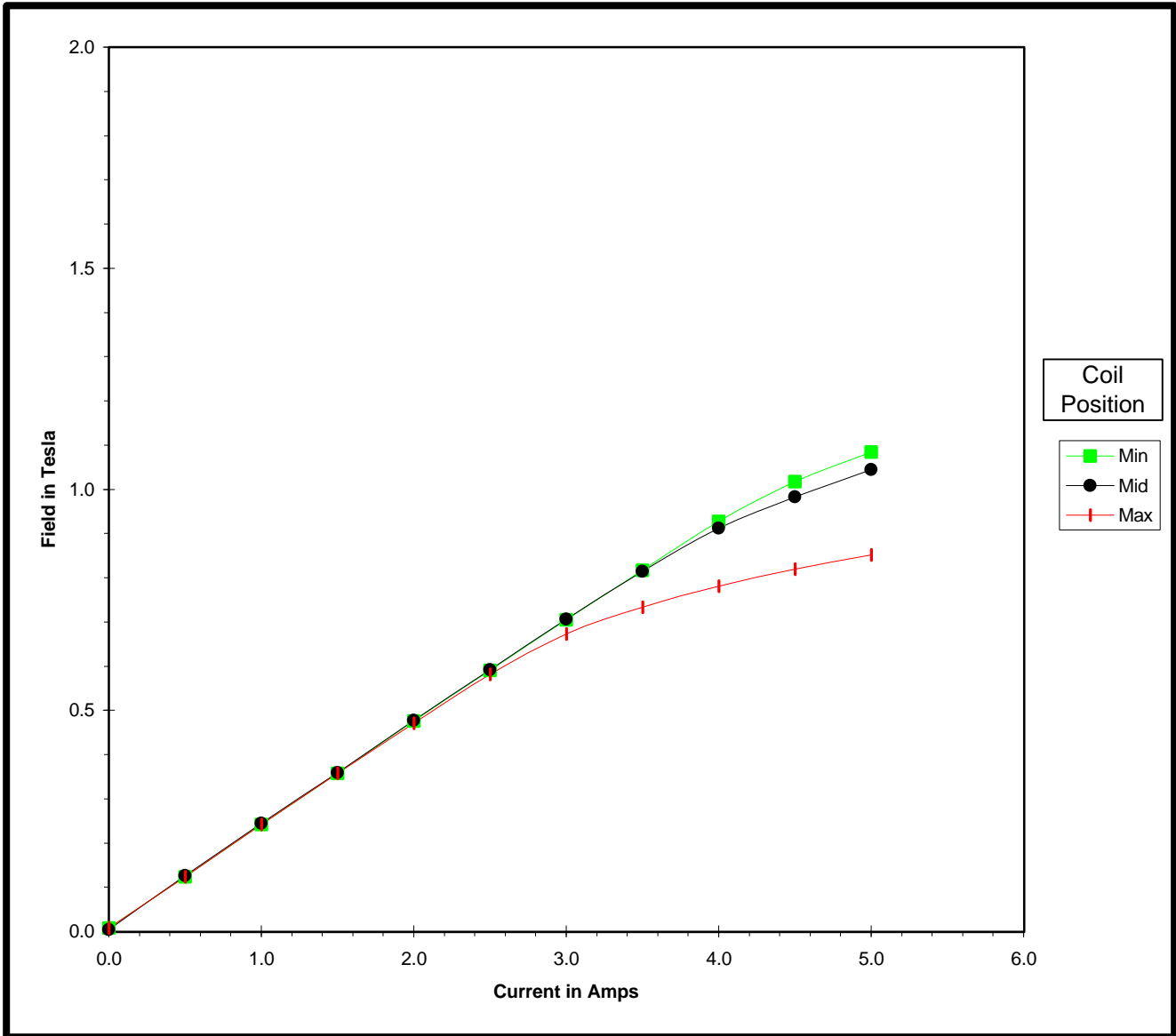

GMW Associates
Electromagnet Excitation Plot
Field Vs Current

Contract No:	Page: 3 of 3	Date:	Oct 17, 95
Customer:		Engr:	G.Douglas
Model: 3470	Power Supply:	Set Current:	
Serial No: 52	Serial No:	Target Field:	
Pole Face: 45 Square	Position: X=0, Y=0, Z=0		
Serial No: None	Notes:		
Pole Gap: 10mm			
Pole Spacers: None			

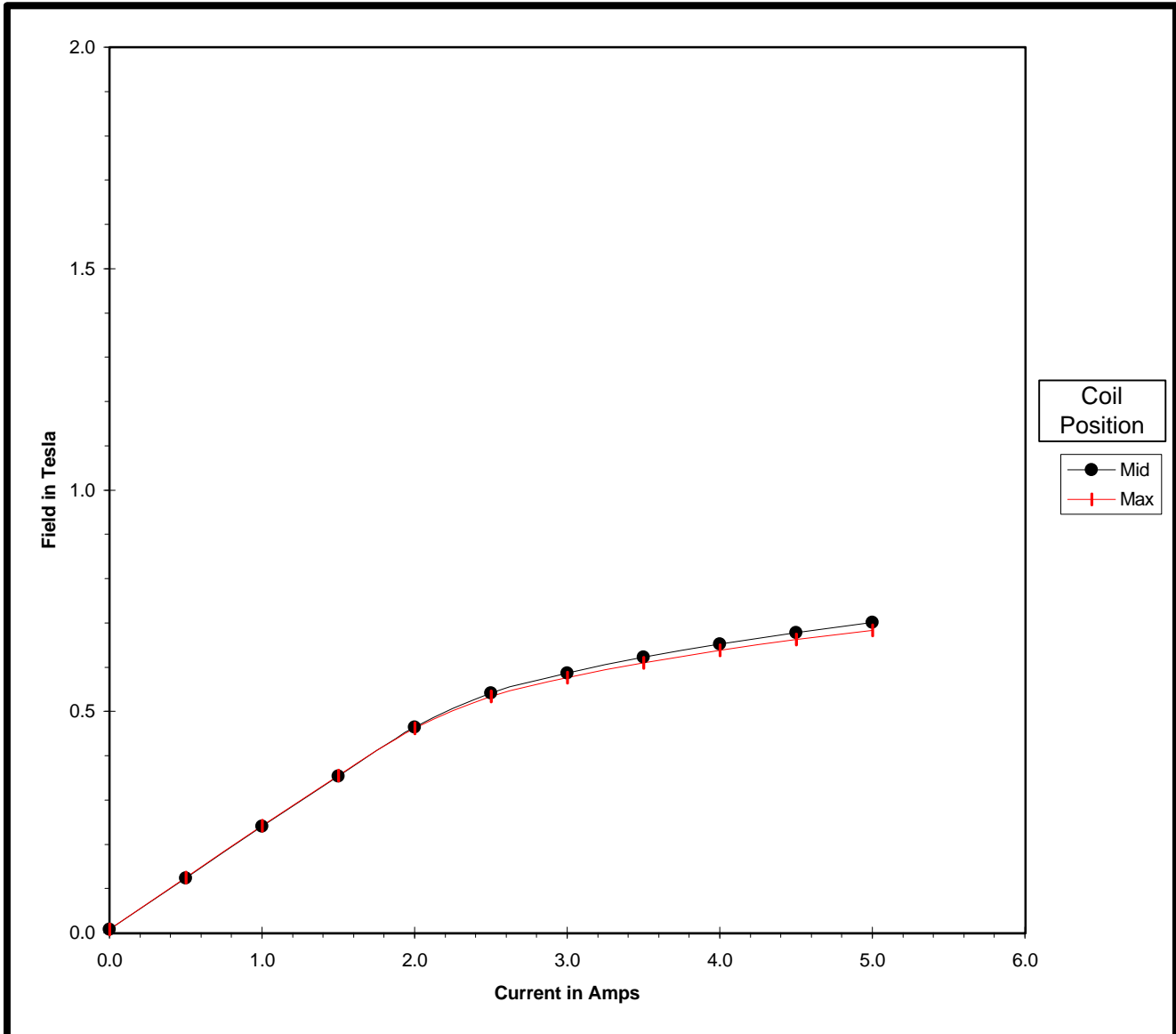

Section 9

TEST DATA

FRONT VIEW

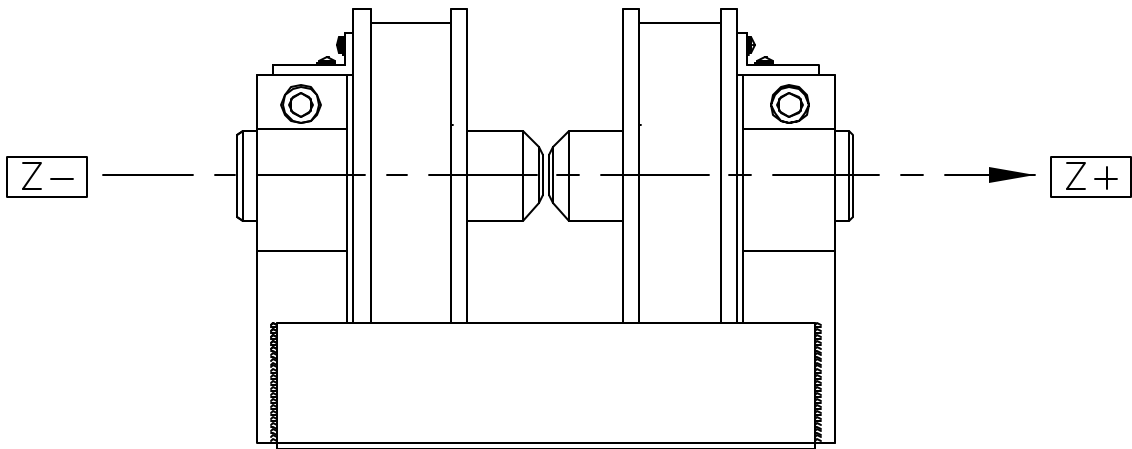

SIDE VIEW

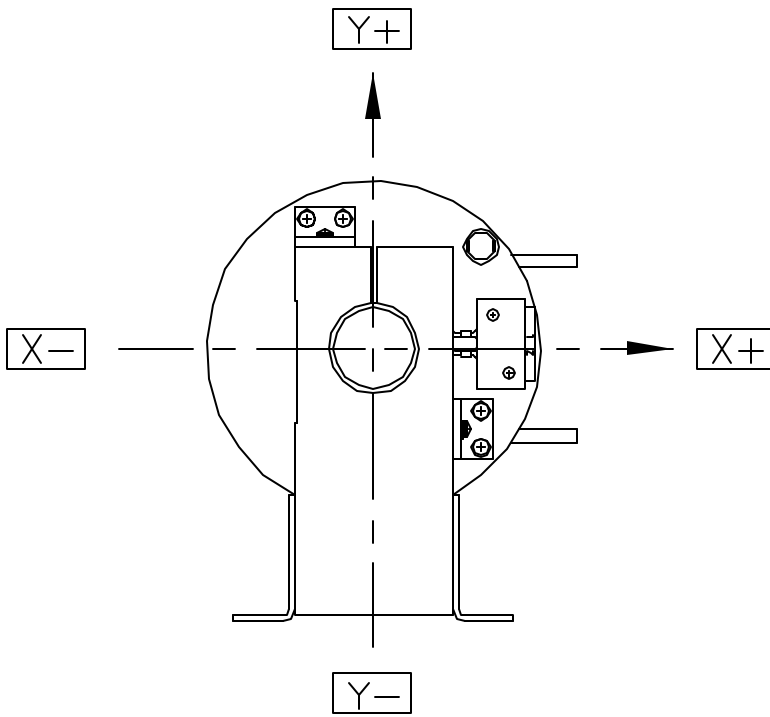

PROPRIETARY

This document contains information proprietary to GMW Inc. It must not be reproduced or disclosed to others or used in any other way, in whole or part, except as authorized in writing by GMW Inc.

MAGNETIC PLOTTING AXIS

80900050

A

SHEET 1 OF 1

GMW ASSOCIATES

LABORATORY ELECTROMAGNET UNIFORMITY PLOT

Model 3470
Serial No 52

Pole Face 20 mm
Pole Gap 10 mm
Magnet Current 5.0 Amps

Engr Greg Douglas
Date Sept 25, 1995

Plot Y = 0.0 mm, Z = 0.0 mm				
X - mm	Magnet Field Tesla	X + mm	Magnet Field Tesla	Magnet Field Average Tesla
0	1.0120600	0	1.0119800	1.0120200
-1	1.0120200	1	1.0118600	1.0119400
-2	1.0115000	2	1.0110400	1.0112700
-3	1.0102600	3	1.0109820	1.0106210
-4	1.0087600	4	1.0073000	1.0080300
-5	1.0047000	5	1.0030600	1.0038800
-6	0.9992600	6	0.9965600	0.9979100
-7	0.9878800	7	0.9861200	0.9870000
-8	0.9701000	8	0.9692600	0.9696800
-9	0.9437000	9	0.9407800	0.9422400
-10	0.9081200	10	0.9034000	0.9057600
0	1.0119800	0	1.0120400	1.0120100

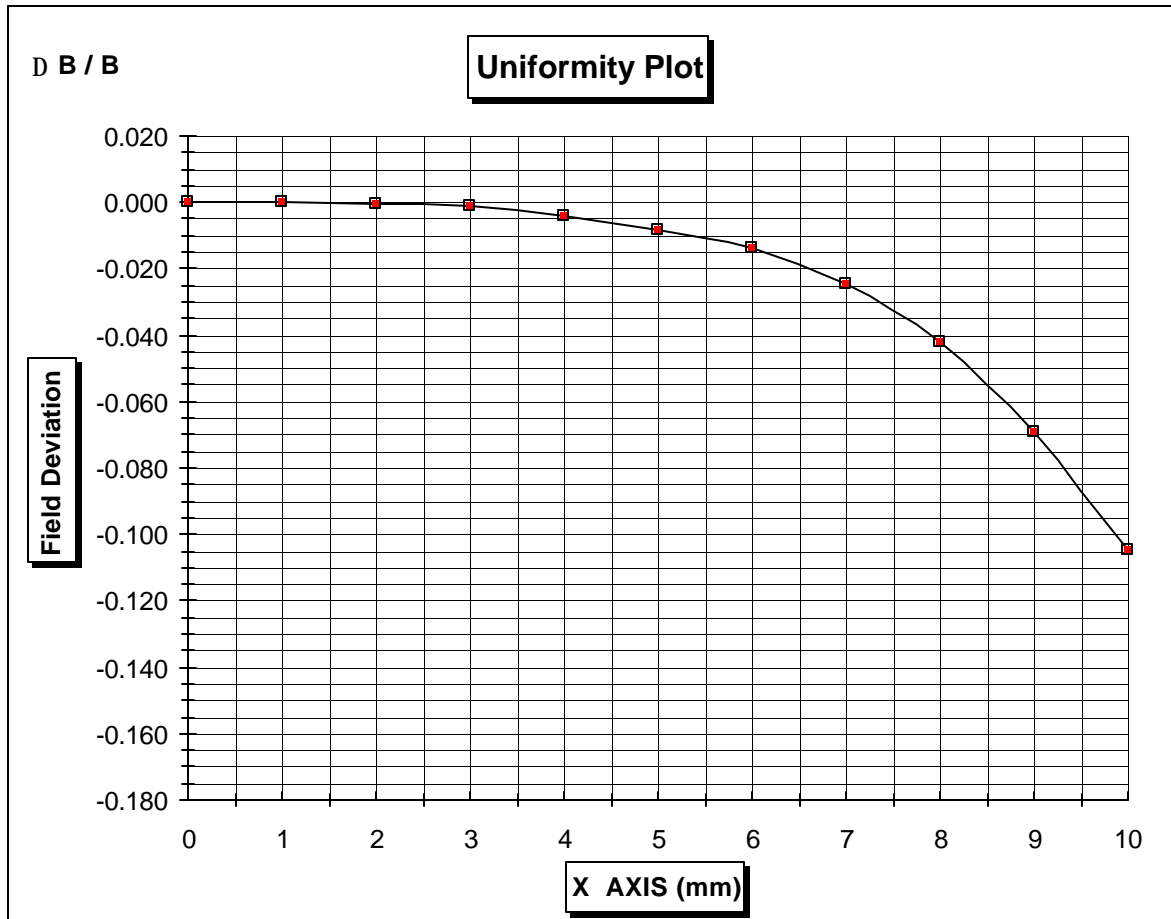

GMW ASSOCIATES

LABORATORY ELECTROMAGNET UNIFORMITY PLOT

Model 3470
Serial No 52

Pole Face 20 mm
Pole Gap 10 mm
Magnet Current 5.0 Amps

Engr Greg Douglas
Date Sept 25, 1995

Plot Y = 0.0 mm, X = 0.0 mm				
Z - mm	Magnet Field Tesla	Z + mm	Magnet Field Tesla	Magnet Field Average Tesla
0	1.012300	0	1.012280	1.012300
-1	1.012940	1	1.012400	1.012670
-2	1.014080	2	1.013160	1.013620
-3	1.015300	3	1.013860	1.014580
-4	1.016060	4	1.016060	1.016060
-5	0.000000	5	0.000000	0.000000
-6	0.000000	6	0.000000	0.000000
-7	0.000000	7	0.000000	0.000000
-8	0.000000	8	0.000000	0.000000
-9	0.000000	9	0.000000	0.000000
-10	0.000000	10	0.000000	0.000000
0	1.012300	0	1.012280	1.012290

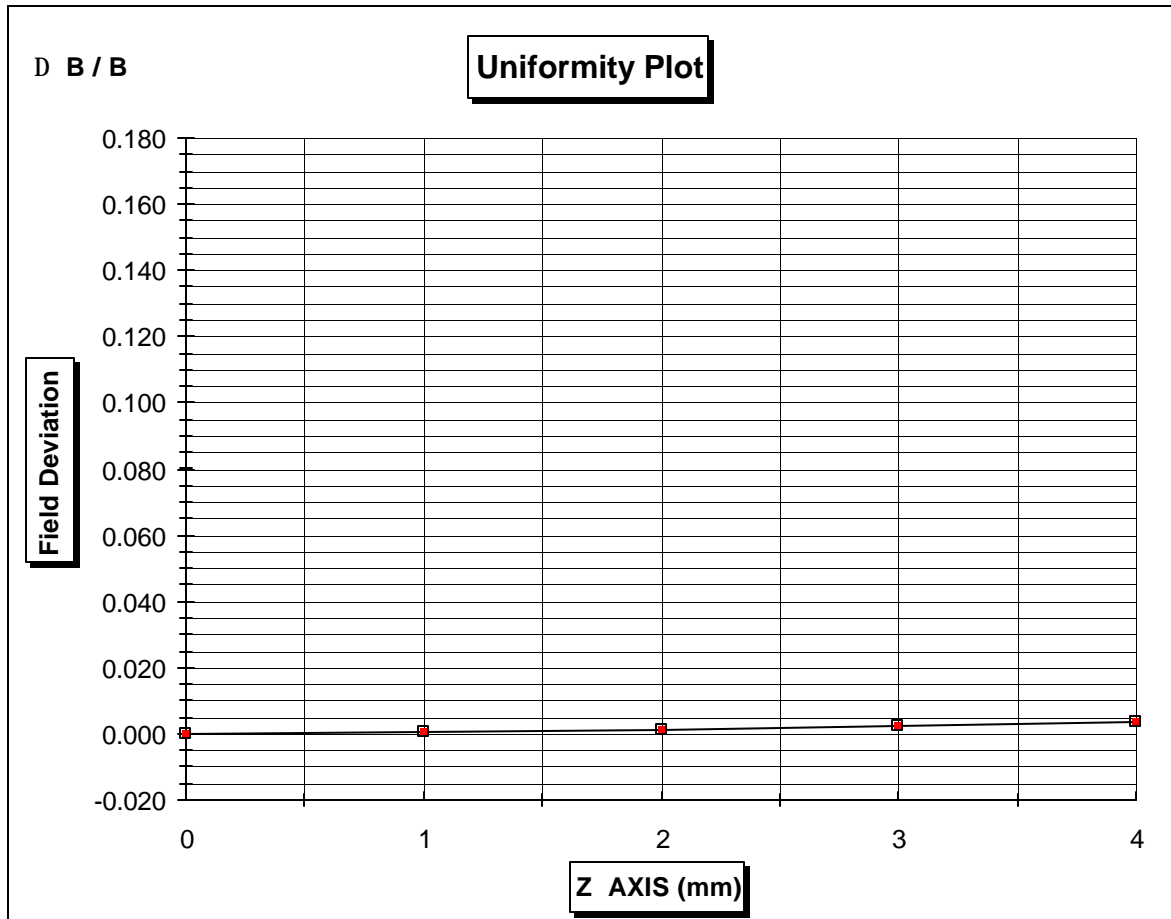

GMW ASSOCIATES

LABORATORY ELECTROMAGNET UNIFORMITY PLOT

Model 3470
Serial No 52

Pole Face 20 mm
Pole Gap 20 mm
Magnet Current 5.0 Amps

Engr Greg Douglas
Date Sept 25, 1995

Plot Y = 0.0 mm, Z = 0.0 mm				
X - mm	Magnet Field Tesla	X + mm	Magnet Field Tesla	Magnet Field Average Tesla
0	0.5493400	0	0.5493800	0.5493600
-1	0.5489200	1	0.5489200	0.5489200
-2	0.5474000	2	0.5475200	0.5474600
-3	0.5450400	3	0.5451600	0.5451000
-4	0.5418200	4	0.5420400	0.5419300
-5	0.5366000	5	0.5365000	0.5365500
-6	0.5299200	6	0.5297600	0.5298400
-7	0.5232600	7	0.5214800	0.5223700
-8	0.5129200	8	0.5133800	0.5131500
-9	0.5010600	9	0.5027600	0.5019100
-10	0.4887600	10	0.4899800	0.4893700
0	0.5493800	0	0.5493800	0.5493800

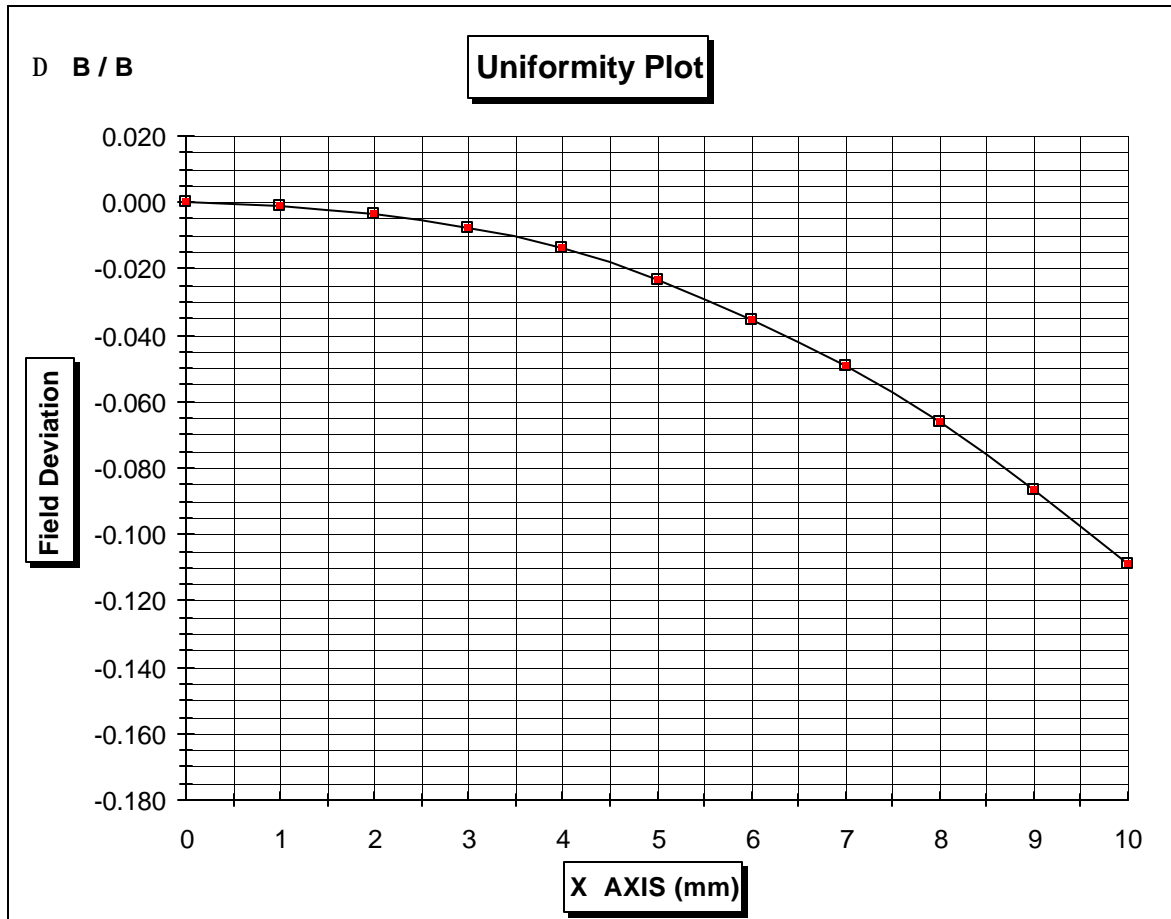

GMW ASSOCIATES

LABORATORY ELECTROMAGNET UNIFORMITY PLOT

Model 3470
Serial No 52

Pole Face 20 mm
Pole Gap 20 mm
Magnet Current 5.0 Amps

Engr Greg Douglas
Date Oct 4, 1995

Plot Y = 0.0 mm, X = 0.0 mm				
Z - mm	Magnet Field Tesla	Z + mm	Magnet Field Tesla	Magnet Field Average Tesla
0	0.549660	0	0.549660	0.549660
-1	0.552300	1	0.548980	0.550640
-2	0.556380	2	0.550040	0.553210
-3	0.562000	3	0.552940	0.557470
-4	0.568460	4	0.557300	0.562880
-5	0.575520	5	0.563160	0.569340
-6	0.581520	6	0.569660	0.575590
-7	0.586900	7	0.576000	0.581450
-8	0.590820	8	0.582540	0.586680
-9	0.000000	9	0.000000	0.000000
-10	0.000000	10	0.000000	0.000000
0	0.549660	0	0.549660	0.549660

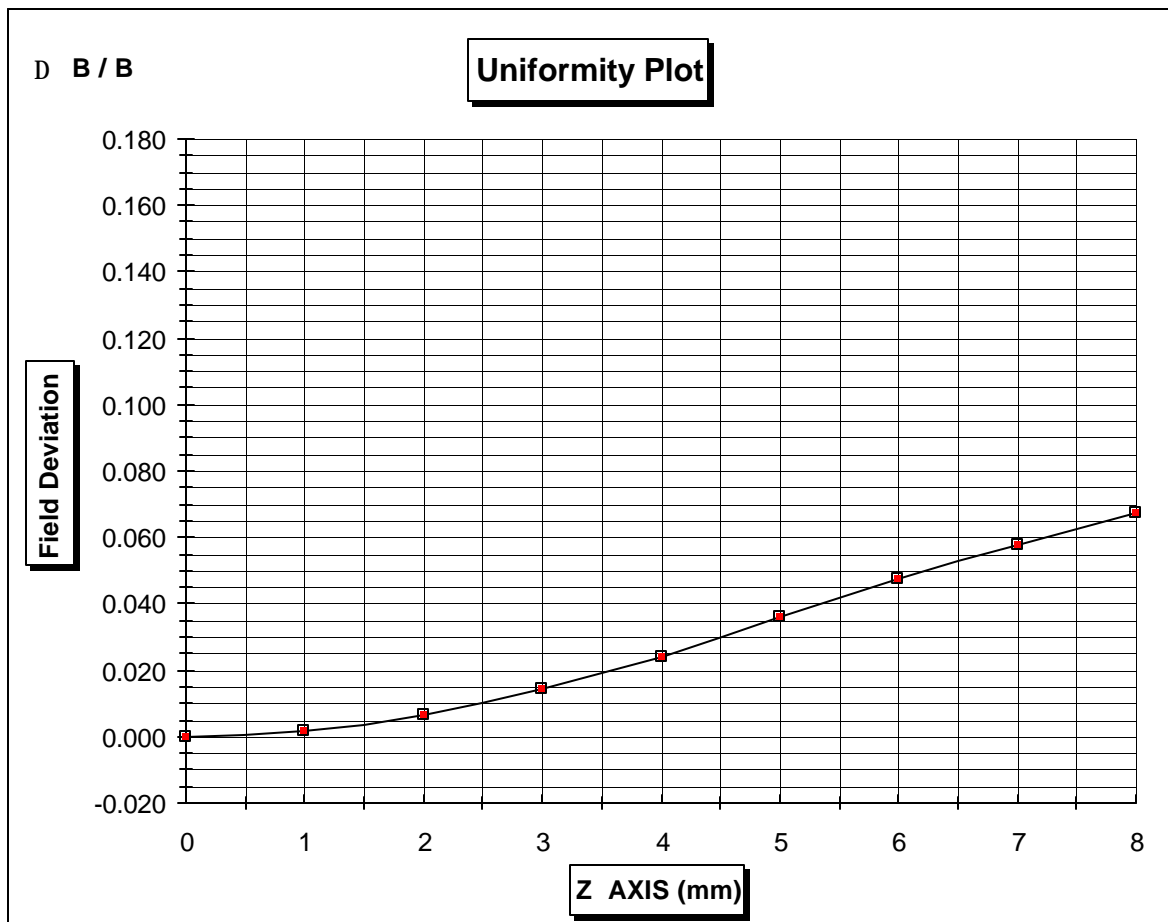

GMW ASSOCIATES

LABORATORY ELECTROMAGNET UNIFORMITY PLOT

Model 3470
Serial No 52

Pole Face 40 mm
Pole Gap 10 mm
Magnet Current 5.0 Amps

Engr Greg Douglas
Date Sept 25, 1995

Plot Y = 0.0 mm, Z = 0.0 mm				
X - mm	Magnet Field Tesla	X + mm	Magnet Field Tesla	Magnet Field Average Tesla
0	0.860880	0	0.860920	0.860900
-2	0.860920	2	0.860860	0.860890
-4	0.860920	4	0.860740	0.860830
-6	0.860900	6	0.860640	0.860770
-8	0.860800	8	0.860420	0.860610
-10	0.860400	10	0.859900	0.860150
-12	0.859540	12	0.858680	0.859110
-14	0.855520	14	0.854940	0.855230
-16	0.844000	16	0.844160	0.844080
-18	0.813680	18	0.812620	0.813150
-20	0.731560	20	0.734980	0.733270
0	0.860920	0	0.860880	0.860900

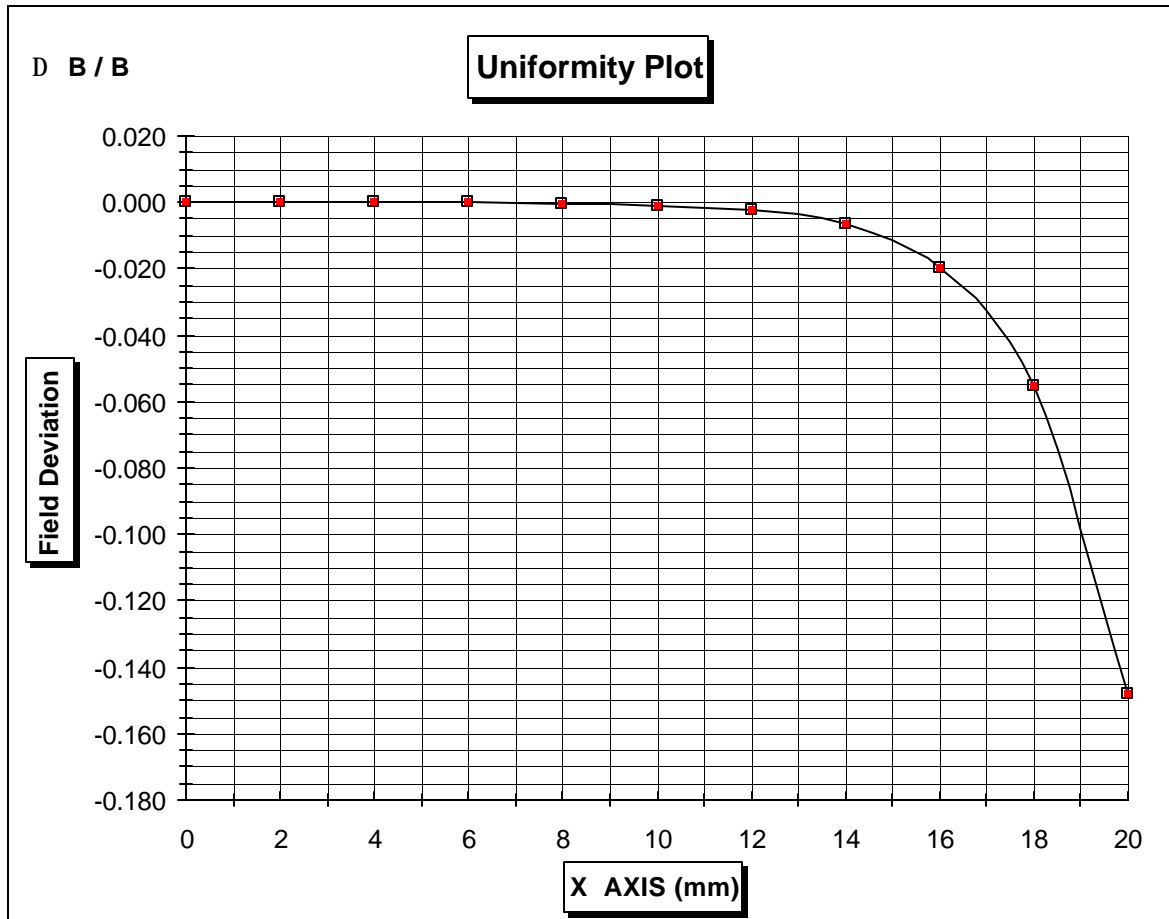

GMW ASSOCIATES

LABORATORY ELECTROMAGNET UNIFORMITY PLOT

Model 3470
Serial No 52

Pole Face 40 mm
Pole Gap 10 mm
Magnet Current 5.0 Amps

Engr Greg Douglas
Date Sept 25, 1995

Plot Y = 0.0 mm, X = 0.0 mm				
Z - mm	Magnet Field Tesla	Z + mm	Magnet Field Tesla	Magnet Field Average Tesla
0	0.859660	0	0.859720	0.859660
-1	0.859740	1	0.859720	0.859730
-2	0.859760	2	0.859740	0.859750
-3	0.859800	3	0.859720	0.859760
-4	0.000000	4	0.000000	0.000000
-5	0.000000	5	0.000000	0.000000
-6	0.000000	6	0.000000	0.000000
-7	0.000000	7	0.000000	0.000000
-8	0.000000	8	0.000000	0.000000
-9	0.000000	9	0.000000	0.000000
-10	0.000000	10	0.000000	0.000000
0	0.859660	0	0.859720	0.859690

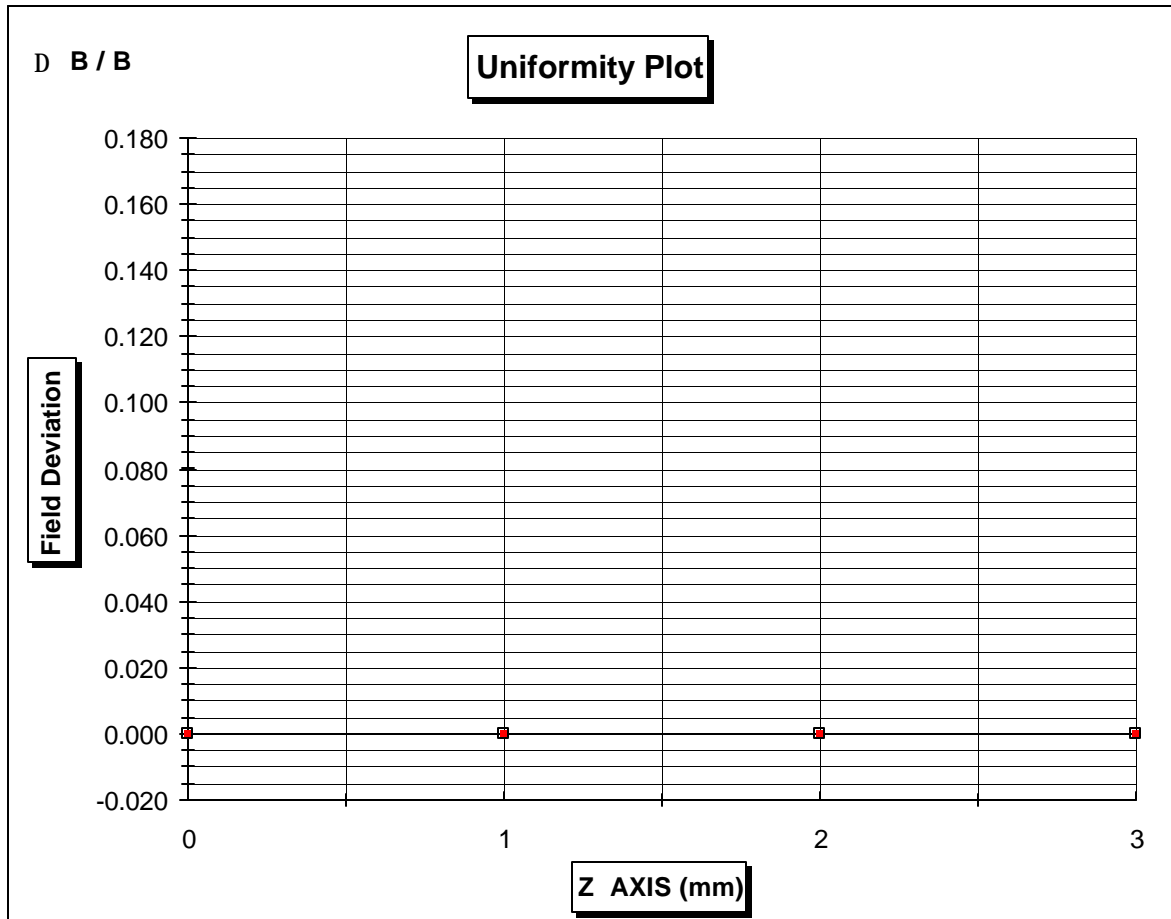

GMW ASSOCIATES

LABORATORY ELECTROMAGNET UNIFORMITY PLOT

Model 3470
Serial No 52

Pole Face 40 mm
Pole Gap 20 mm
Magnet Current 5.0 Amps

Engr Greg Douglas
Date Sept 25, 1995

Plot Y = 0.0 mm, X = 0.0 mm				
Z - mm	Magnet Field Tesla	Z + mm	Magnet Field Tesla	Magnet Field Average Tesla
0	0.530930	0	0.530980	0.530930
-1	0.531120	1	0.530950	0.531035
-2	0.531490	2	0.531060	0.531275
-3	0.531960	3	0.531340	0.531650
-4	0.532430	4	0.531730	0.532080
-5	0.533060	5	0.532310	0.532685
-6	0.533500	6	0.532810	0.533155
-7	0.533990	7	0.533290	0.533640
-8	0.534300	8	0.533660	0.533980
-9	0.000000	9	0.000000	0.000000
-10	0.000000	10	0.000000	0.000000
0	0.530930	0	0.530980	0.530955

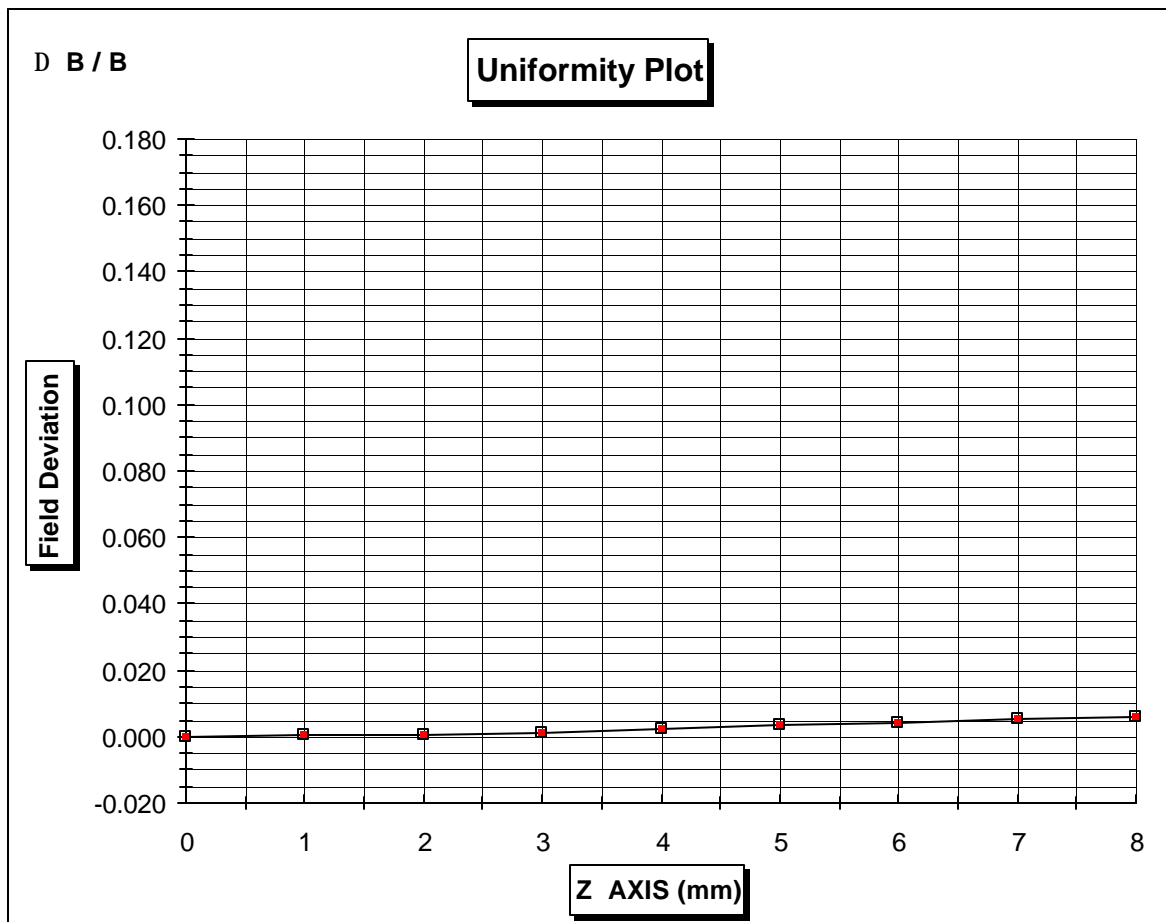

GMW ASSOCIATES

LABORATORY ELECTROMAGNET UNIFORMITY PLOT

Model 3470
Serial No 52

Pole Face 40 mm
Pole Gap 20 mm
Magnet Current 5.0 Amps

Engr Greg Douglas
Date Sept 25, 1995

Plot Y = 0.0 mm, Z = 0.0 mm				
X - mm	Magnet Field Tesla	X + mm	Magnet Field Tesla	Magnet Field Average Tesla
0	0.531040	0	0.530103	0.530572
-2	0.530910	2	0.530880	0.530895
-4	0.530400	4	0.530300	0.530350
-6	0.529350	6	0.529180	0.529265
-8	0.527310	8	0.527230	0.527270
-10	0.524040	10	0.523480	0.523760
-12	0.518710	12	0.517320	0.518015
-14	0.509470	14	0.508250	0.508860
-16	0.494600	16	0.494310	0.494455
-18	0.470950	18	0.469040	0.469995
-20	0.438590	20	0.435750	0.437170
0	0.530103	0	0.531020	0.530562

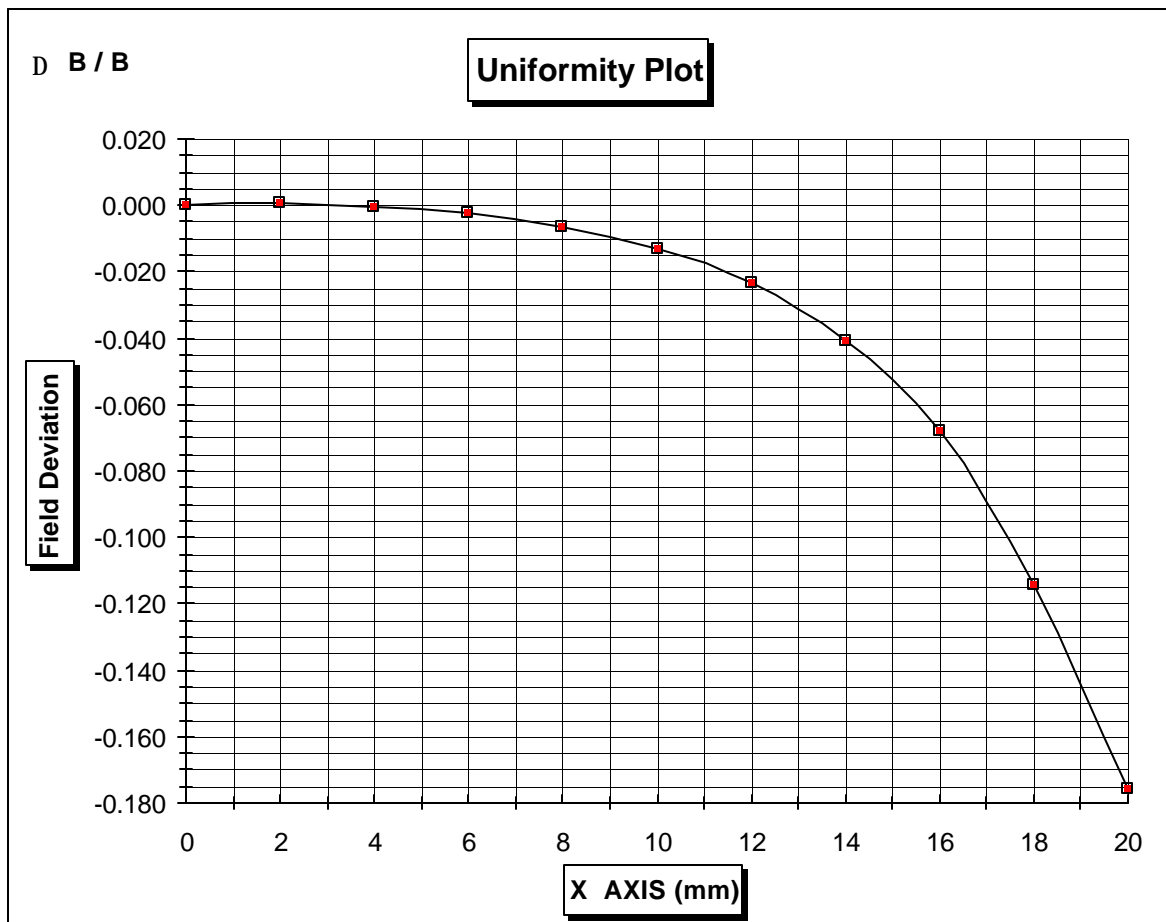

GMW ASSOCIATES

LABORATORY ELECTROMAGNET UNIFORMITY PLOT

Model 3470
Serial No 52

Pole Face Square 45 mm
Pole Gap 10 mm
Magnet Current 5.0 Amps

Engr Greg Douglas
Date Sept 22, 1995

Plot Y = 0.0 mm, Z = 0.0 mm				
X - mm	Magnet Field Tesla	X + mm	Magnet Field Tesla	Magnet Field Average Tesla
0	0.678080	0	0.678080	0.678080
-2	0.678100	2	0.678180	0.678140
-4	0.678160	4	0.678140	0.678150
-6	0.678220	6	0.678120	0.678170
-8	0.678300	8	0.678100	0.678200
-10	0.678340	10	0.678060	0.678200
-12	0.678300	12	0.677900	0.678100
-14	0.677880	14	0.677340	0.677610
-16	0.676300	16	0.675700	0.676000
-18	0.671040	18	0.670160	0.670600
-20	0.655880	20	0.652620	0.654250
0	0.678080	0	0.678200	0.678140

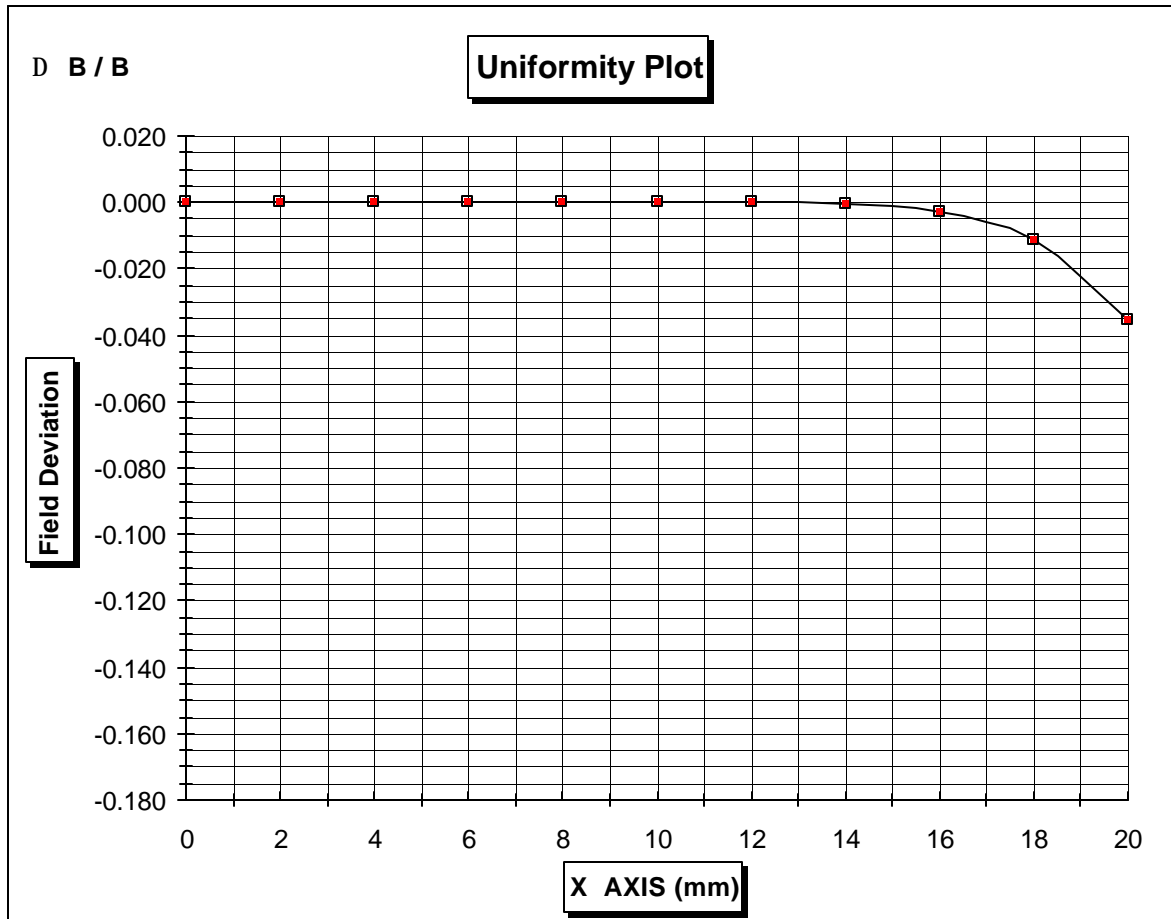

GMW ASSOCIATES

LABORATORY ELECTROMAGNET UNIFORMITY PLOT

Model 3470
Serial No 52

Pole Face Square 45 mm
Pole Gap 10 mm
Magnet Current 5.0 Amps

Engr Greg Douglas
Date Sept 22, 1995

Plot Y = 0.0 mm, X = 0.0 mm				
Z - mm	Magnet Field Tesla	Z + mm	Magnet Field Tesla	Magnet Field Average Tesla
0	0.678180	0	0.678180	0.678180
-1	0.678180	1	0.678180	0.678180
-2	0.678160	2	0.678180	0.678170
-3	0.678140	3	0.678180	0.678160
-4	0.000000	4	0.000000	0.000000
-5	0.000000	5	0.000000	0.000000
-6	0.000000	6	0.000000	0.000000
-7	0.000000	7	0.000000	0.000000
-8	0.000000	8	0.000000	0.000000
-9	0.000000	9	0.000000	0.000000
-10	0.000000	10	0.000000	0.000000
0	0.678180	0	0.678180	0.678180

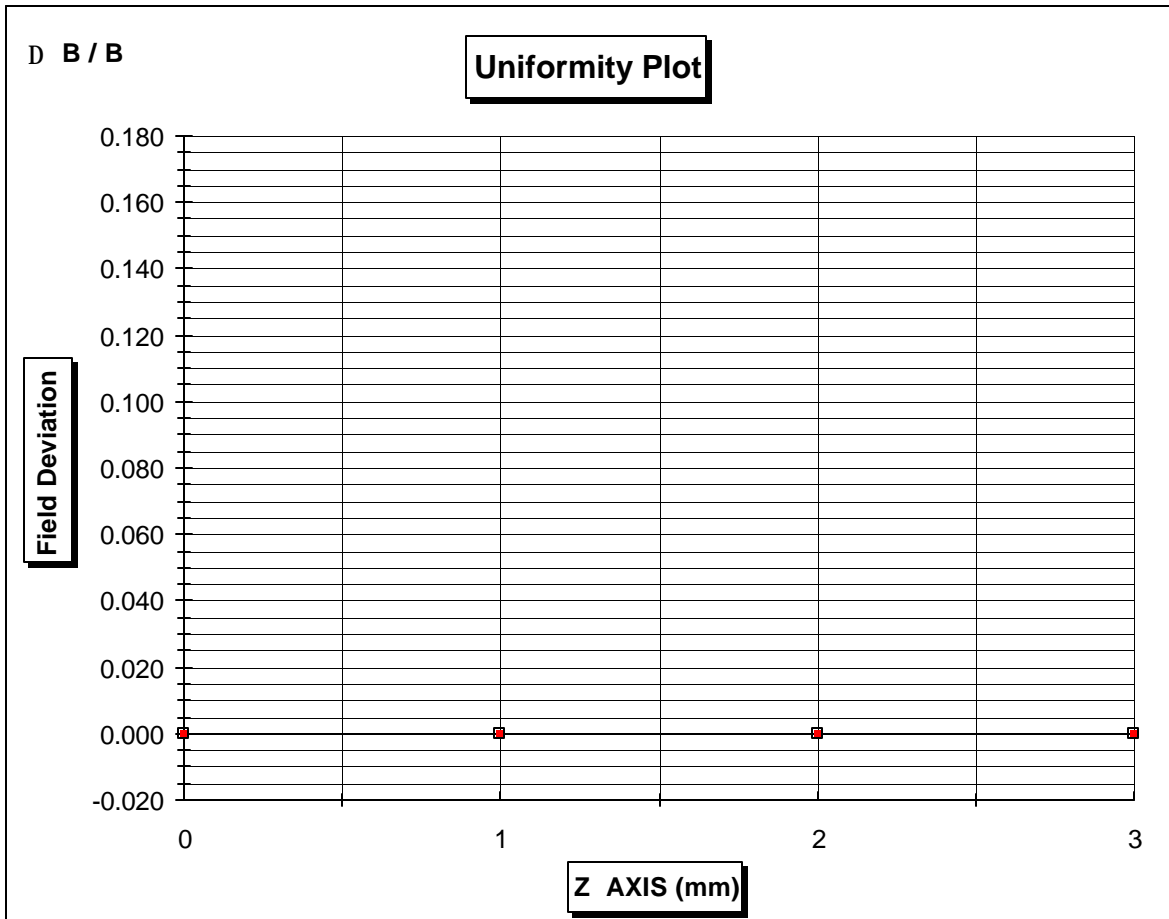

GMW ASSOCIATES

LABORATORY ELECTROMAGNET UNIFORMITY PLOT

Model 3470
Serial No 52

Pole Face Square 45 mm
Pole Gap 20 mm
Magnet Current 5.0 Amps

Engr Greg Douglas
Date Sept 22, 1995

Plot Y = 0.0 mm, Z = 0.0 mm				
X - mm	Magnet Field Tesla	X + mm	Magnet Field Tesla	Magnet Field Average Tesla
0	0.458850	0	0.458840	0.458845
-2	0.458830	2	0.458790	0.458810
-4	0.458730	4	0.458660	0.458695
-6	0.458550	6	0.458370	0.458460
-8	0.458040	8	0.457920	0.457980
-10	0.457130	10	0.456930	0.457030
-12	0.455510	12	0.455050	0.455280
-14	0.452490	14	0.452130	0.452310
-16	0.447390	16	0.446840	0.447115
-18	0.437380	18	0.437120	0.437250
-20	0.422420	20	0.421550	0.421985
0	0.458840	0	0.458830	0.458835

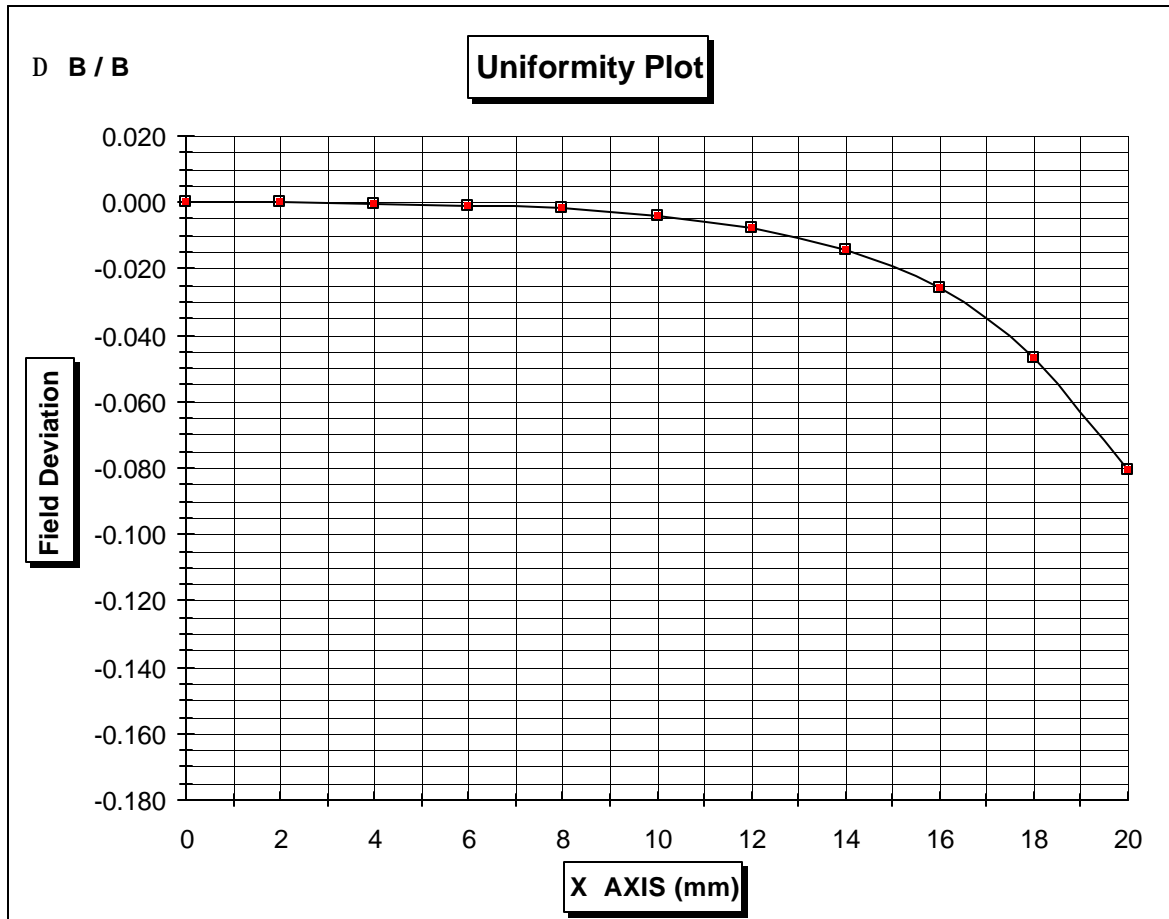

GMW ASSOCIATES

LABORATORY ELECTROMAGNET UNIFORMITY PLOT

Model 3470
Serial No 52

Pole Face Square 45 mm
Pole Gap 20 mm
Magnet Current 5.0 Amps

Engr Greg Douglas
Date Sept 22, 1995

Plot Y = 0.0 mm, X = 0.0 mm				
Z - mm	Magnet Field Tesla	Z + mm	Magnet Field Tesla	Magnet Field Average Tesla
0	0.455440	0	0.455480	0.455460
-1	0.455460	1	0.455460	0.455460
-2	0.455540	2	0.455480	0.455510
-3	0.455620	3	0.455540	0.455580
-4	0.455720	4	0.455660	0.455690
-5	0.455820	5	0.455780	0.455800
-6	0.455880	6	0.455880	0.455880
-7	0.455980	7	0.456020	0.456000
-8	0.456020	8	0.456100	0.456060
-9	0.000000	9	0.000000	0.000000
-10	0.000000	10	0.000000	0.000000
0	0.455480	0	0.455460	0.455470

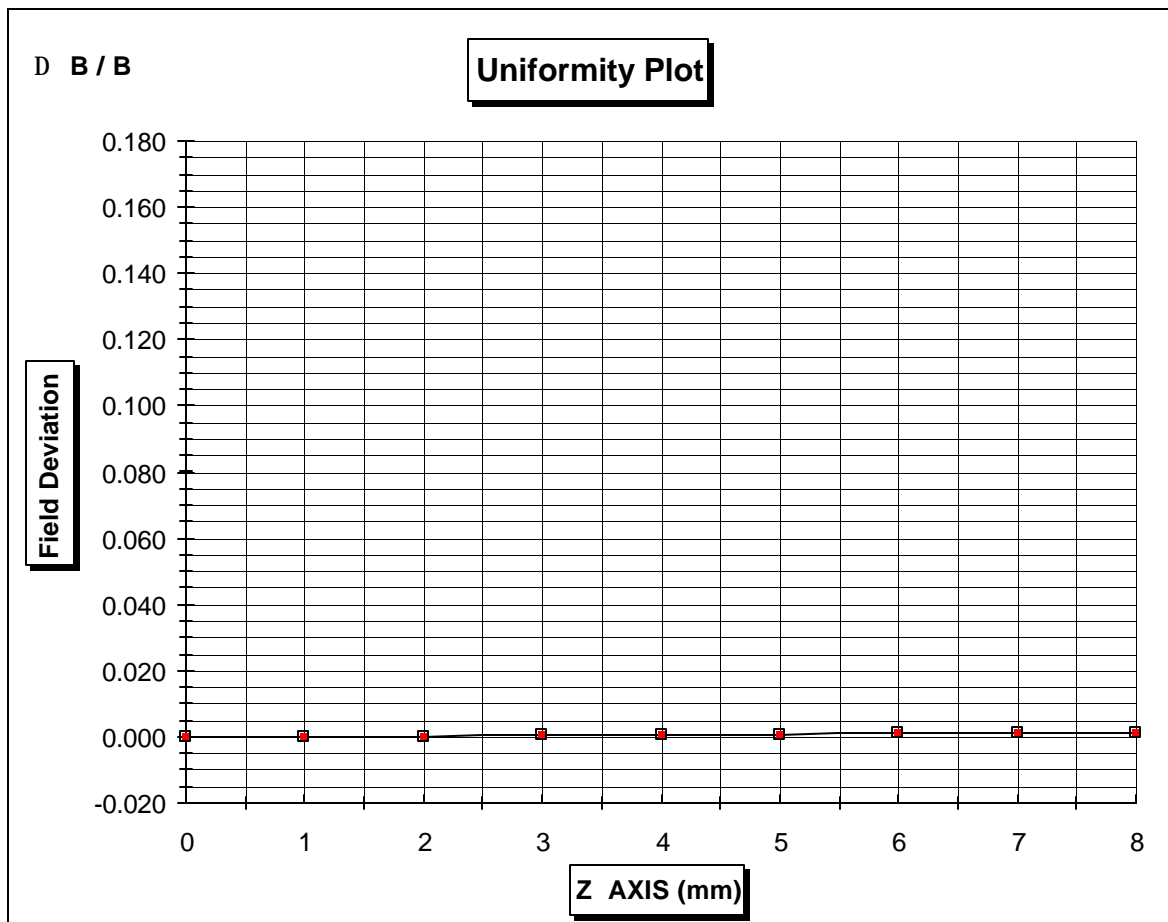

Section 10

DRAWINGS

SERIES 3450/3450R/3455R/3455RBV 15 AMP THERMOSTATS

Typical Applications:

Power Supplies

Communication
Equipment

Medical Equipment

Computers (Where
High AMP Loads are
Present)



The Series 3450/3455R is a snap-acting, non-adjustable precision thermostat especially suited for industrial and electrical equipment.

The 3450 (.390" or 10mm overall) is ideal for applications that require precision control of high electric loads to 8 Amp resistive.

The 3450R and 3455R have a patented metal insert rivet construction.

The 3455R (.484" or 12.5mm) overall, has higher spacing as required by European approval agencies. Model 3455RBV is an epoxy overmold version of the 3455R, specifically designed for electrical insulation or protection in a high humidity environment. Consult factory for performance qualifications.

To insure that a safe combination of thermostat and application is achieved, the purchaser must determine product suitability for their individual requirements.

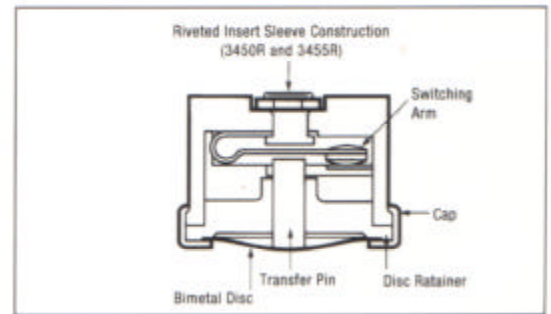

*Series 3450/3450R/3455R/3455RBV

MODEL	ELECTRIC LIFE CYCLES	120 VAC	240 VAC	277VAC
3450	100,000	8.0A	-	-
3450R/	100,000	15A	8.3A	7.2A
3455R	100,000	4.4FLA 25.4LRA	2.2FLA 13.2LRA	-
	6,000	5.8FLA 34.8LRA	2.9FLA 17.4LRA	-
3455RBV	100,000	15A	8.3A	-
	6,000	5.8A 34.8LRA	2.9A 17.4LRA	-

A: Amps

FLA: Full Load Amps

LRA: Locked Rotor Amps

Contacts are available for millivolt and milliamp applications.

*Includes UL and CSA ratings.

Consult Elmwood Sensors for additional ratings.

Key Features:

- Electric Rating to 15 Amp 120 VAC Resistive
- Environmental Exposure 0° to 350° F (-18° to 177° C)
- UL recognized and CSA certified and European Approved
- Single-Pole, Single-Throw (SPST)
- Pre-set and Tamperproof
- Variety of Mounting Brackets and Terminals Available

SERIES 3450/3450R/3455R/3455RBV 15 AMP THERMOSTATS

Standard Temperature Characteristics

Operating Temperature Range The tightest specification determines the group	Tolerance Allowable ^a ± at mean temperature set points				Standard Mean Differential Nominal degrees between opening and closing points		Price Group ^a
	Open		Close		°F	°C	
	±°F	±°C	±°F	±°C			
32° to 79°F 0° to 25°C	5	2.8	8	4.4	30-50	16-28	I
	5	2.8	7	3.9	25-29	14-16	II
	5	2.8	6	3.3	20-24	11-13	III
	5	2.8	6	3.3	15-19	8-11	IV
80° to 200°F 25° to 95°C	5	2.8	8	4.4	30-50	16-28	I
	5	2.8	7	3.9	25-29	14-16	II
	5	2.8	6	3.3	20-24	11-14	III
	6	2.2	5	2.8	15-19	8-11	IV
201 to 250°F 96° to 120°C	6	4.4	8	4.4	30-50	16-28	I
	6	3.9	7	3.9	25-29	14-16	II
	6	3.3	6	3.3	20-24	11-14	III
	6	2.8	6	2.8	15-19	8-11	IV
251 to 302°F 121.7° to 148.9°C	7	3.9	8	4.4	30-50	16-28	I
	7	3.9	7	3.9	30-50	16-28	II
	7	3.9	7	3.9	20-29	11-16	III
	6	3.3	7	3.9	15-19	8-11	IV

^aGrouped according to level of accuracy required. Group I with greatest latitude is less expensive than Group II, etc. Please consult factory for temperature ranges, tolerances and differentials not noted. The operating temperature ranges include tolerances.

The ± tolerances shown have been established after careful review of many thermostat applications. Attempts should be made to establish the widest acceptable tolerance possible. For example, the chart may list a tolerance of ±5°F (±2.8°C); however, ±6°F (±3.3°C) may be acceptable for the application at reduced cost.

Note: Temperature checking methods may be slightly different, and allowance for a 1.8°F (1°C) variance should be considered.

See Section B of the Terminal and Bracket Guide for dimensional characteristics.

Operating Parameters

Dielectric Strength	MIL-STD-202 Method 301 -2000 VAC 60 Hz - Terminal to Case
Insulation Resistance	MIL-STD-202 Method 302 Cond. B - 500 Megohms - 500 Volts DC applied
Environmental Exposure	0° to 350°F (-18° to 177°C)
Operating Temp. Range	32° to 302°F (0° to 150°C)
Contact Resistance	MIL-STD-202, Method 307 - 50 Milliohms
Marking	MIL-STD-1285
Weight	6 Grams (Brackets and wire leads not included)
Materials	Base: Phenolic Terminals: Plated Brass or Steel Closure: Aluminum, Stainless Steel, or Brass Brackets: Aluminum, Stainless Steel, or Brass Contacts: Silver

UL and CSA Listings

UL and CSA Listings are for use in equipment where the acceptability of the combination of the thermostat and equipment is determined by Underwriters' Laboratories, Inc. and/or the Canadian Standards Association.

UL File E36103, UL File SA4469 (3455RBV only), UL File MH8267 (3455R only), CSA File 21048.

REVISIONS

REV	RELEASE	DESCRIPTION	DWFT	DATE	APPROVED
A	RELEASE			02/14/93	A.MARTIN
B	ADD ITEM 15 TO 23 DELETE COIL LINK WIRE			04/27/94	GDOUGLAS
C	REMOVE NOTE 1, CHG PART NO'S ITEMS 19, 23-25			07/16/93	GDOUGLAS
D	MAGNET TERMINAL BOX ADDED, REV NOT IMPLEMENTED			02/29/93	M.DUFFY
E	CHG WATER PIPE, 1/8" LAYOUT, IMPLEMENTED AFTER SH 195			02/29/93	GDOUGLAS
F	CHG TEMP SW TO 50° C, IMPLEMENTED AFTER SH 205			04/21/98	GDOUGLAS

ELECTROMAGNET REAR VIEW

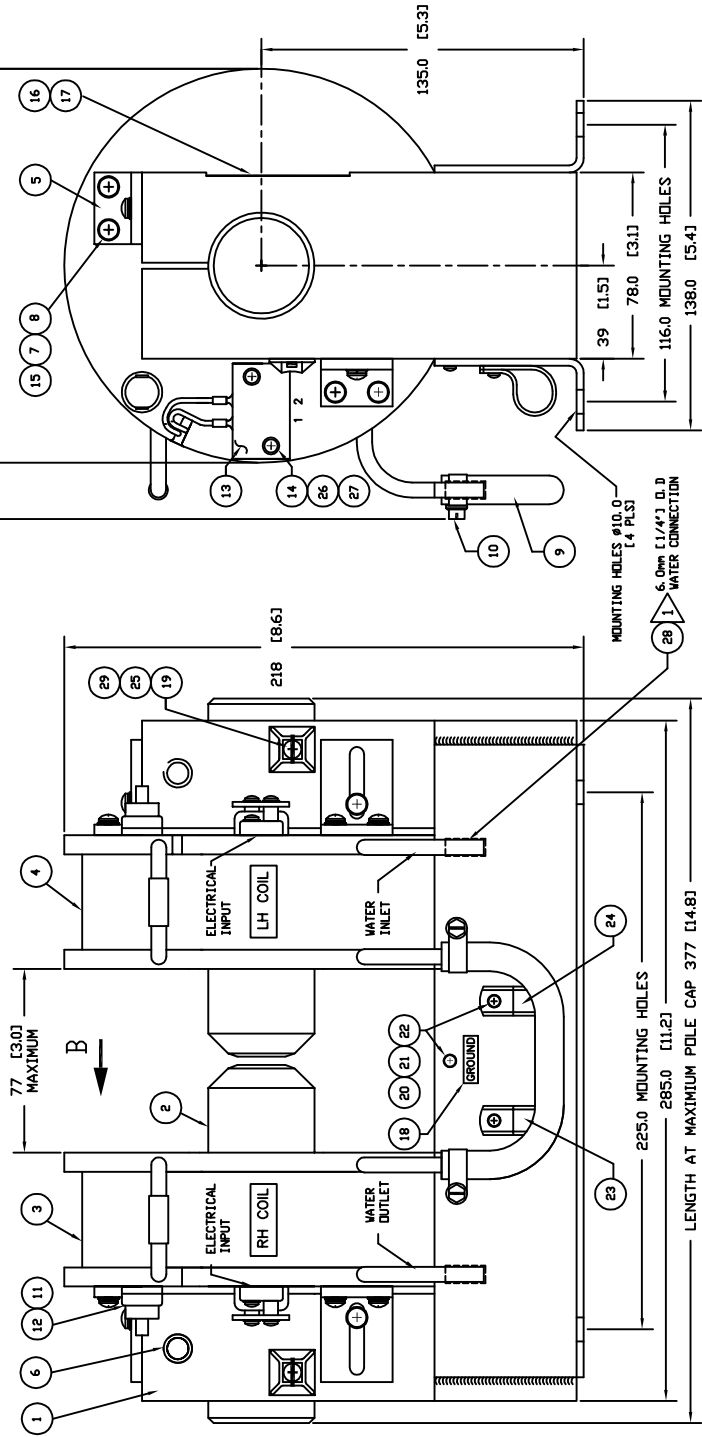

ELECTROMAGNET SCHEMATIC REAR VIEW

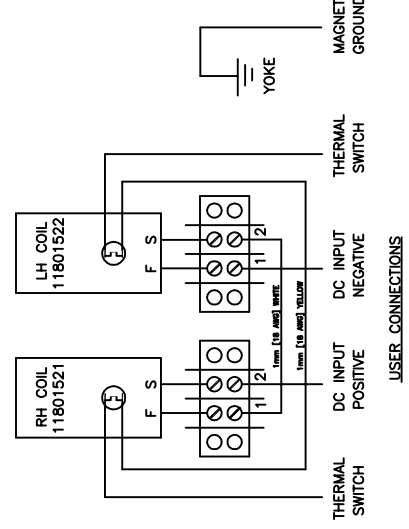

ELECTROMAGNET SPECIFICATIONS

- POLE DIAMETER, CYLINDRICAL END 40 mm [1.57"]
- POLE DIAMETER, TAPERED END 20 mm [0.787"]
- POLE GAP 0 TO 75 mm [3"]
- COILS (see las connected)
- MAX RESISTANCE 8.8 ohm
- MAX POWER [air] 3.5A/31V
- MAX POWER [water] 5A/44V
- COOLING 1 liter/min [0.26 gpm] 0.3 bar [5 psi]
- THERMAL INTERLOCK ABOVE 50° C [122° F]
- OPEN CIRCUIT 120VAC/0.17A
- RESISTIVE RATING 27 Kg [60 lbs]
- WEIGHT

NOTE: DO NOT EXCEED THE MAXIMUM SPECIFIED COIL RESISTANCE OR COIL OVERHEATING AND POSSIBLE DAMAGE MAY OCCUR.

NOTE

1. AFTER FINAL TEST PURGE WATER LINES AND FIT (ITEM 28) TO WATER INLET/OUTLET.
2. SUPPLY TWO HOSE CLAMPS (ITEM 10) PACKED IN PLASTIC BAG WITH EACH MAGNET.

DATE	DATE	DESCRIPTION	DATE	DATE	APPROVED
02/14/93	02/14/93				A.MARTIN
04/27/94	04/27/94				GDOUGLAS
07/16/93	07/16/93				GDOUGLAS
02/29/93	02/29/93				M.DUFFY
04/21/98	04/21/98				GDOUGLAS

ITEM	QTY	PART NUMBER	DESCRIPTION	NOTE
29	2	DIN 965A	SCREW, M4 x 6 FLAT HD PHILLIPS S/S	
28	2	SC0063	PLASTIC SEALING CAPS, 6.3 ID, KELVINDALE	
27	4	DIN 433	M3 WASHER, FLAT S/S	
26	4	DIN 7980	M3 WASHER, SPRING S/S	
25	2	268-513	CABLE TIE, 3.6mm WIDE NATURAL FARNELL	
24	1	PCBK-9	P-CLIP 10mm ID, BLACK NYLON CABAC	
23	1	PCBK-8	P-CLIP 8mm ID, BLACK NYLON CABAC	
22	3	DIN 7980	M4 WASHER, SPRING S/S	
21	3	DIN 433	M4 WASHER, FLAT S/S	
20	3	DIN 7985A	M4 x 10 PAN HD PHILLIPS SCREW S/S	
19	2	268-690	CABLE TIE PAD, COLOR NATURAL, FARNELL	
18	1	10900720	LABEL, GROUND	
17	1	10900710	LABEL, CAUTION [RH SIDE]	
16	1	10900700	LABEL, MAGNET SPECIFICATION [LH SIDE]	
15	12	DIN 7980	M5 WASHER, SPRING S/S	
14	4	DIN 7985A	M3 x 20 PAN HD PHILLIPS SCREW S/S	
13	2	17801570	TERMINAL COVER	
12	2		WASHER, NEOPRENE 16x4x4mm	
11	2	3450 GB611-2	TEMPERATURE SENSOR 50°C ELIMWOOD	
10	4	INDENT 72-173	HOSE CLAMP 8-12 S/S, NORMA	
9A/R	10	442732	HOSE 7/32" ID BLACK RUBBER, GATES	
8	12	DIN 433	M5 WASHER, FLAT S/S	
7	12	DIN 7985A	M5 x 12 PAN HD PHILLIPS SCREW S/S	
6	4	17801560	COIL MTS BRACKET	
5	4	17801522	COIL [LH]	
4	3	11801521	COIL [RH]	
3	2	17801500	POLE	
2	1	11801480	YOKES ASSEMBLY	
1	1	11801470	YOKES ASSEMBLY	

DATE	DATE	DESCRIPTION	DATE	DATE	APPROVED
02/14/93	02/14/93				A.MARTIN
04/27/94	04/27/94				GDOUGLAS
07/16/93	07/16/93				GDOUGLAS
02/29/93	02/29/93				M.DUFFY
04/21/98	04/21/98				GDOUGLAS

DATE	DATE	DESCRIPTION	DATE	DATE	APPROVED
02/14/93	02/14/93				A.MARTIN
04/27/94	04/27/94				GDOUGLAS
07/16/93	07/16/93				GDOUGLAS
02/29/93	02/29/93				M.DUFFY
04/21/98	04/21/98				GDOUGLAS

SCALE 1:1 WT KG SHEET 1 OF 1

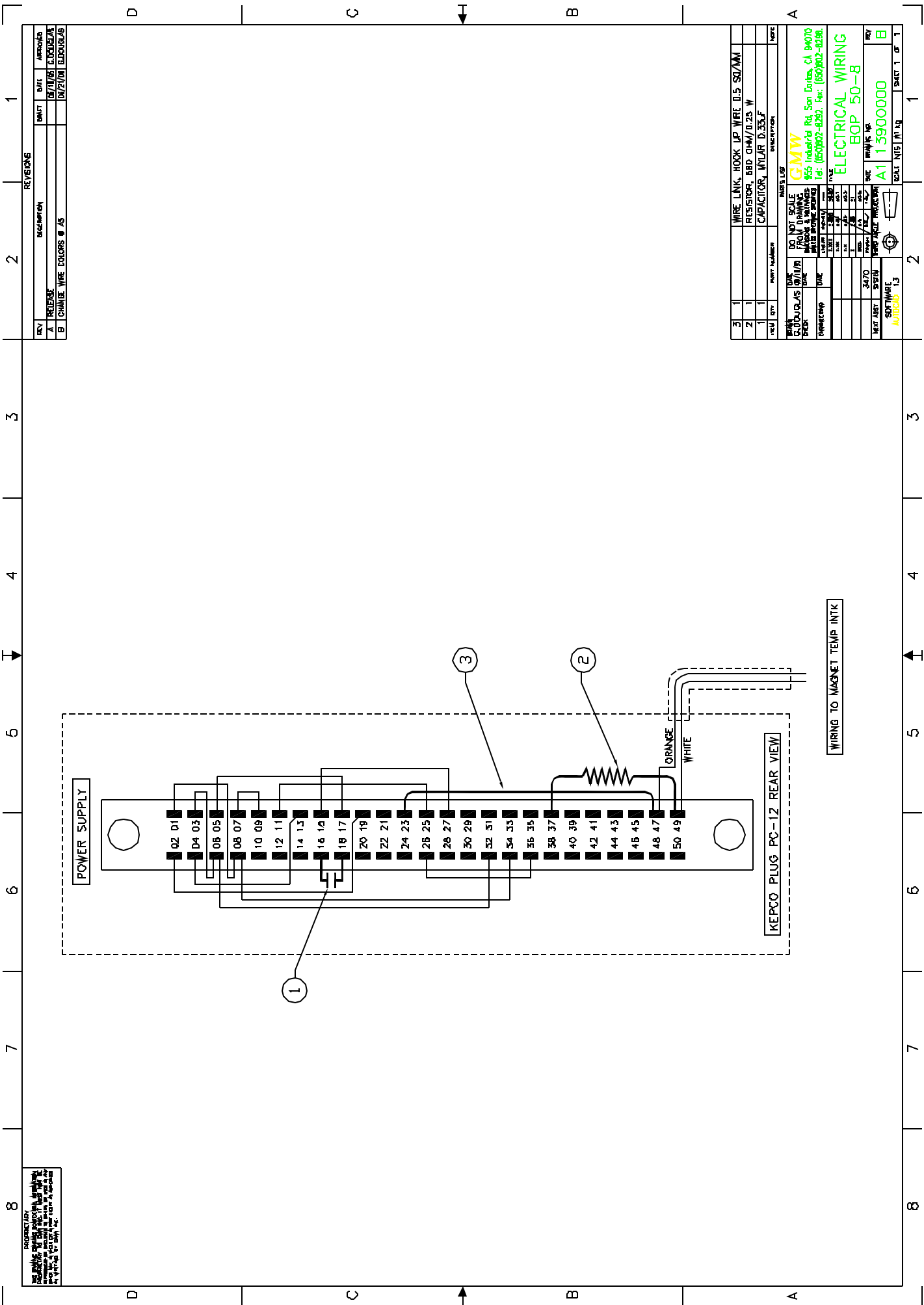

REVISIONS			
REV	DESCRIPTION	DATE	APPROVED
A	REVERSE		
B	CHANGE WIRE COLORS @ J5		

PARTS LIST		DESCRIPTION	
3	1	WIRE LINK, HOOK UP, WIRE 0.5 SQ/MM	
2	1	RESISTOR, 820 OHM/0.25 W	
1	1	CAPACITOR, 10UF 50V	

DO NOT SCALE		PARTS LIST	
QTY	DESCRIPTION	QTY	DESCRIPTION
1	WIRE LINK, HOOK UP, WIRE 0.5 SQ/MM	1	RESISTOR, 820 OHM/0.25 W
1	CAPACITOR, 10UF 50V	1	WIRE LINK, HOOK UP, WIRE 0.5 SQ/MM

GMW		ELECTRICAL WIRING	
REV	DATE	REV	DATE
A	11/20/00	B	11/20/00
B	11/20/00	A1	11/20/00

PROJECT INFORMATION		DRAWING INFORMATION	
PROJECT	2470	SCALE	AS SHOWN
DESCRIPTION	TEMP SENSITIVITY	DATE	11/20/00
REV	1.3	BY	GMW
APP'D		CHECKED	
DATE		DATE	

PROPRIETARY
 INFORMATION
 THIS DRAWING IS THE PROPERTY OF GMW AND IS NOT TO BE REPRODUCED OR TRANSMITTED IN ANY FORM OR BY ANY MEANS, ELECTRONIC OR MECHANICAL, INCLUDING PHOTOCOPYING, RECORDING, OR BY ANY INFORMATION STORAGE AND RETRIEVAL SYSTEM, WITHOUT THE WRITTEN PERMISSION OF GMW, INC.

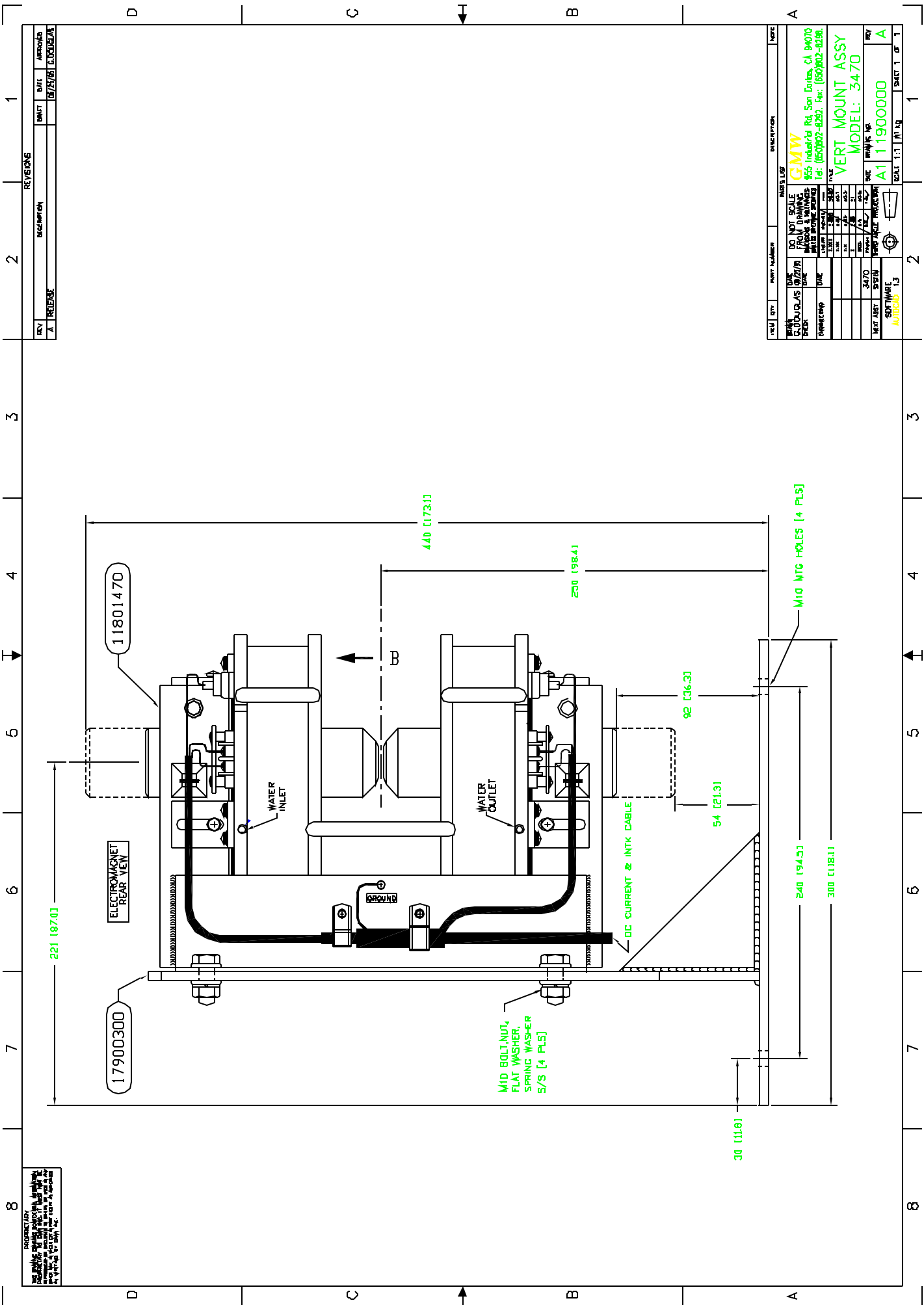

REVISIONS			
REV	DESCRIPTION	DATE	APPROVED
A	RELEASE	08/23/06	C. DORRIS

PART NUMBER		DESCRIPTION	
11801470	EM MAGNET	11801470	EM MAGNET
17900300	BASE	17900300	BASE
110 MTC HOLES (4 PLS)	110 MTC HOLES (4 PLS)	110 MTC HOLES (4 PLS)	110 MTC HOLES (4 PLS)
DC CURRENT & INTK CABLE	DC CURRENT & INTK CABLE	DC CURRENT & INTK CABLE	DC CURRENT & INTK CABLE
M10 BOLT, NUT, FLAT WASHER, SPRING WASHER 5/8 [4 PLS]	M10 BOLT, NUT, FLAT WASHER, SPRING WASHER 5/8 [4 PLS]	M10 BOLT, NUT, FLAT WASHER, SPRING WASHER 5/8 [4 PLS]	M10 BOLT, NUT, FLAT WASHER, SPRING WASHER 5/8 [4 PLS]
WATER INLET	WATER INLET	WATER INLET	WATER INLET
WATER OUTLET	WATER OUTLET	WATER OUTLET	WATER OUTLET
221 (87.0)	221 (87.0)	221 (87.0)	221 (87.0)
440 (173.1)	440 (173.1)	440 (173.1)	440 (173.1)
240 (94.5)	240 (94.5)	240 (94.5)	240 (94.5)
300 (118.1)	300 (118.1)	300 (118.1)	300 (118.1)
92 (36.3)	92 (36.3)	92 (36.3)	92 (36.3)
54 (21.3)	54 (21.3)	54 (21.3)	54 (21.3)
30 (11.8)	30 (11.8)	30 (11.8)	30 (11.8)

PROPRIETARY
 THE INFORMATION CONTAINED HEREIN IS THE PROPERTY OF GMW AND IS NOT TO BE DISCLOSED TO ANY OTHER PARTY WITHOUT THE WRITTEN PERMISSION OF GMW, INC.

GMW
 455 Industrial Rd. San Diego, CA 94070
 Tel: (650)802-8292 Fax: (650)802-8298
 VERT MOUNT ASSY
 MODEL: 3470
 PART NUMBER: A111900000
 SHEET 1 OF 1

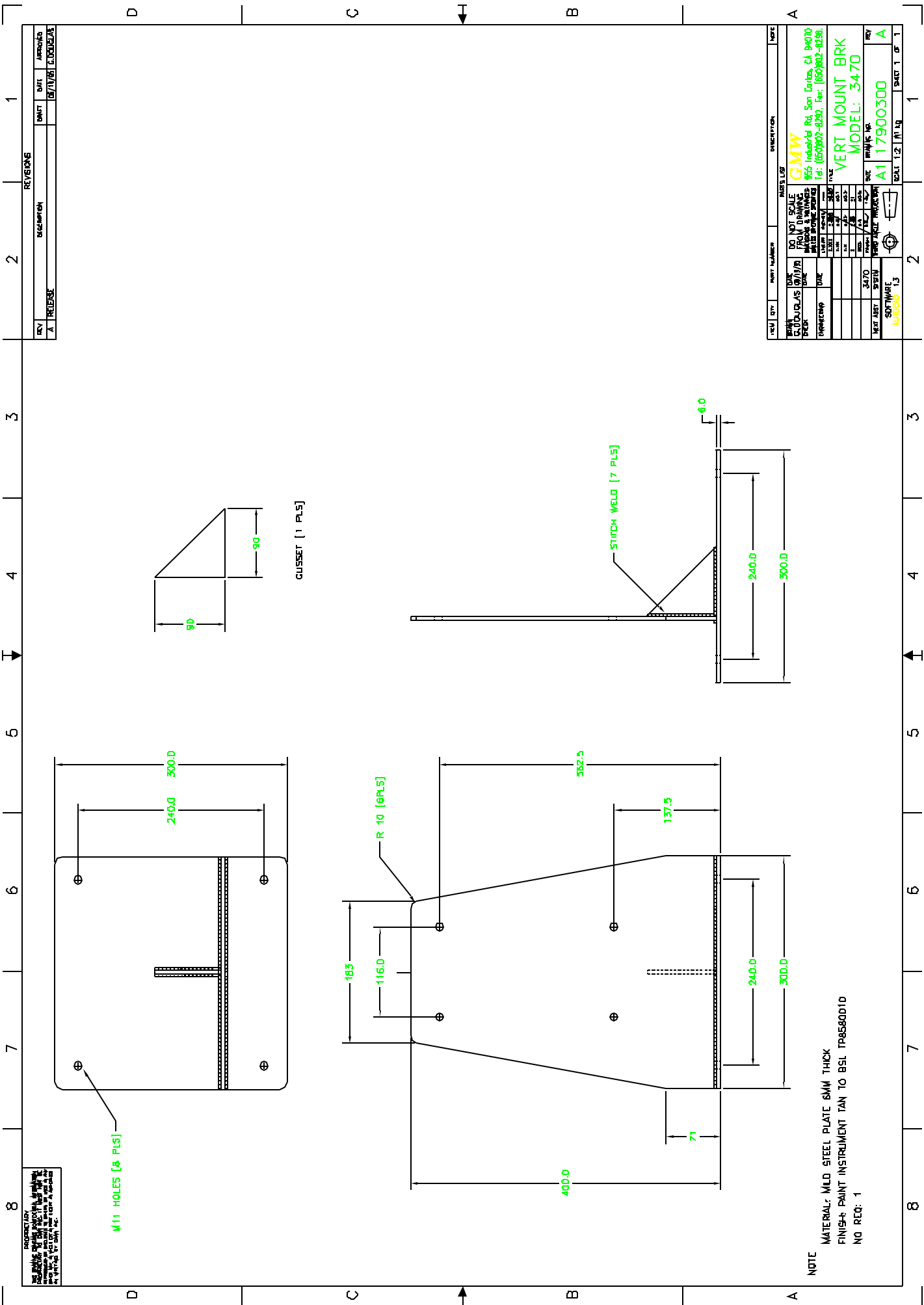

REVISIONS		DATE	APPROVED
REV	DESCRIPTION	DATE	APPROVED
A	RELEASE	07/17/01	C. DORRILL

PART NUMBER		DESCRIPTION	
ITEM	QTY	NO. IN LOT	SCALE
1	1	1	1:1
PART NAME		VERT MOUNT BRK	
PART NUMBER		A1 17900300	
REV		A	
DATE		07/17/01	
DRAWN BY		C. DORRILL	
CHECKED BY		C. DORRILL	
APPROVED BY		C. DORRILL	
DATE		07/17/01	
SCALE		1:1	
SHEET NUMBER		1 OF 1	
SHEET TOTAL		1 OF 1	

PROPRIETARY
 THE DESIGN AND DRAWING INFORMATION CONTAINED HEREIN IS THE PROPERTY OF GMW, INC. AND IS NOT TO BE REPRODUCED OR TRANSMITTED IN ANY FORM OR BY ANY MEANS, ELECTRONIC OR MECHANICAL, INCLUDING PHOTOCOPYING, RECORDING, OR BY ANY INFORMATION STORAGE AND RETRIEVAL SYSTEM, WITHOUT THE WRITTEN PERMISSION OF GMW, INC.

NOTE
 MATERIAL: MILD STEEL PLATE 6MM THICK
 FINISH: PAINT INSTRUMENT TAN TO BSL TP856001D
 NO REQ: 1

GMW
 455 Industrial Rd. San Diego, CA 94010
 Tel: (650)802-8202 Fax: (650)802-8208
 VERT MOUNT BRK
 MODEL: 3470
 PART NUMBER: A1 17900300

PROPRIETARY
 THIS DRAWING CONTAINS CONFIDENTIAL INFORMATION
 PROPRIETARY TO GIMW INC. IT MUST NOT BE
 REPRODUCED OR DISCLOSED TO OTHERS OR USED IN ANY
 OTHER WAY IN WHOLE OR IN PART EXCEPT AS AUTHORIZED
 IN WRITING BY GIMW INC.

REVISIONS

REV	DESCRIPTION	DRAFT	DATE	APPROVED
A	RELEASE		08/15/93	A.MARTIN
B	CHANGE SOCKET SET SCREW AND THREAD TO M5		04/27/94	G.DOUGLAS

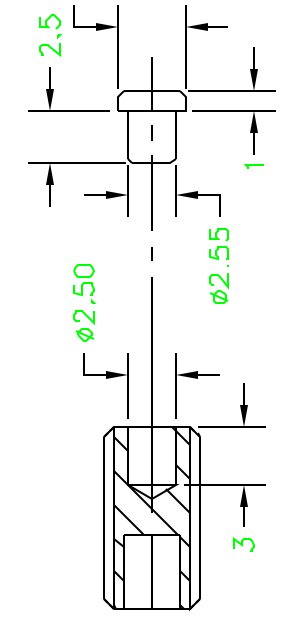
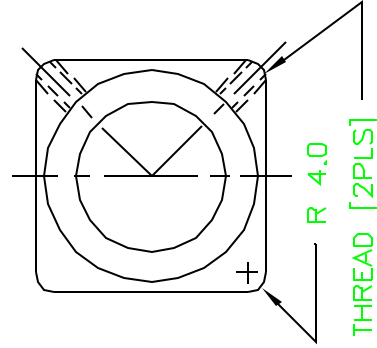
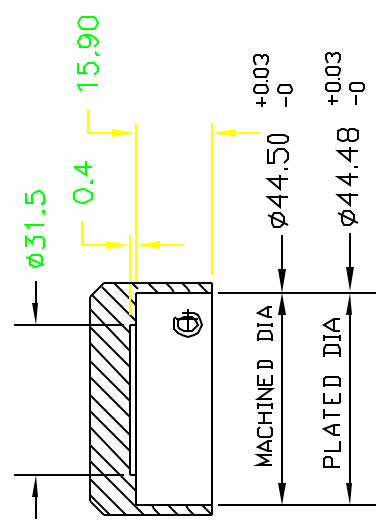

M5 SK SET SCREW
 S/S [2 RQD]
 TIP-COPPER
 [2 RQD]

SCALE 4 : 1

GRAIN
 3 X 45°
 ALL ROUND

SURFACE GRIND

M5 THREAD [2PLS]

1. MATERIAL 1010 LOW CARBON PLATE
 CUT MATERIAL IN DIRECTION OF PLATE GRAIN
 AS INDICATED
3. REMOVE ALL SHARP EDGES 0.1 MAX.
4. EN PLATE 0.01 THICK TO BSL TP85800120

ITEM	QTY	PART NUMBER	DESCRIPTION	NOTE
PARTS LIST				
DRAWN	A.MARTIN	DATE	08/15/93	DO NOT SCALE FROM DRAWING
CHECK		DATE		DIMENSIONS & TOLERANCES (UNLESS OTHERWISE SPECIFIED)
ENGINEERING		DATE		LINEAR INCHES/mm
				X.XXX ±.005 ±0.1
				X.X ±.03 ±0.3
				X ±.06 ±1
				DEC. ±.5 ±0.5
11801470		3470		FINISH 63 1.5
NEXT ASSY		SYSTEM		THIRD ANGLE PROJECTION
SOFTWARE		AUTOCAD 13		
TITLE		GIMW P.O. Box 2578, Redwood City, CA 94064 Tel: (650)802-8292, Fax: (650)802-8298. SQUARE POLE CAP MODEL: 3470		
SIZE		DRAWING NO. A3 17802760		
SCALE		1:1 WT kg SHEET 1 OF 1		

