

ULTRASTAB 867-60I Precision Current Transducer

The Ultrastab 867-60I Current Transducer is a model in the Ultrastab Current Transducer program.

It is the second generation of current transducers from Danfysik with transducer head and SMD based electronics integrated in one assembly.

The 867-60I features a new zero flux detector construction with extreme low noise feed back, compact in size and competitive in price.

It ranges 0-60A from DC to 100kHz with a temperature drift lower than 0.1ppm/°C. Powered with $\pm 15V$ it produces an analog output current of 100mA at 60A primary current.

Output noise and noise feed back to the main conductor are both extremely low, and electrostatic shielding ensures maximum immunity against external electrostatic fields.

The 867-60I features

- Bandwidth DC to 100kHz
- Linearity better than 20ppm
- Traceable absolute calibration
- Temperature drift less than 0.1ppm/°C
- Bipolar - up to 60A primary current with 100mA output current
- Low noise on output signal
- Noise feed-back to main conductor <30 μV
- Resolution better than 1ppm

Applications

- Feed back element in high performance gradient amplifiers
- Feed back element in precision current regulated power supplies

North American Distributor: GMW Associates • 955 Industrial Rd • San Carlos, CA 94070 • USA
Tel +1 650 802 8292 • Fax +1 650 802 8298 • sales@gmw.com • www.gmw.com

Working principle

The Ultrastab 867 Current Transducer system is a unique design, based on the zero flux principle for galvanically isolated current measurement.

The Ultrastab 867 has a built-in free-running oscillator, which drives the zero flux detector circuitry.

With the primary current conductor through the transducer head center hole and current flowing, the electronics will generate a current in the built-in compensation winding counterbalancing the primary ampere turns.

A very sensitive and extremely low noise detector circuit will detect when zero flux is obtained, and an analog current signal will be generated at the output terminals in direct proportion to the primary current.

Installation

The Ultrastab 867-60I unit is fully self-contained, requiring only $\pm 15V$ voltage supply. All connections via a 9-pole D-sub socket.

It can be installed in any orientation and has a high immunity against external magnetic and electrostatic fields.

With the 867 delivered with the standard transfer ratio of 600:1, a 60A primary current will generate a 100mA compensation current. Wired up with a 5 Ohm Burden resistor, a 0.5V analogue output signal will be available.

On the attached installation data sheet it can be seen that the 867-60I can operate with higher resistance values of Burden resistors, but in order to get the best performance out of the Burden resistors, we recommend to keep the power loss as low as possible.

Standard features

The Ultrastab 867 is equipped with opto insulator for status interlock reading. A LED on the front shows NORMAL OPERATION i.e. interlock status ok.

The Ultrastab 867 has a built-in scanning/lock in circuit for automatic recovery to normal operation after overload condition.

Accessories

- 9-pole D-sub with 2m shielded cable
- 5 Ohm Burden resistor (2 x 10 Ohm), 0.1%, $T_c < 3\text{ppm}/^\circ\text{C}$
- 10 Ohm Burden resistor (1 x 10 Ohm), 0.1%, $T_c < 3\text{ppm}/^\circ\text{C}$

Ordering information standard

- 867-60I current transducer
- 866/867-BR5 Burden resistor
- 866/867-BR10 Burden resistor
- 866/867-SC, 2m shielded cable
- 866/867-BB bus bar

Ultrastab 867-60I

PRELIMINARY DRAFT: 08.07.2008

Part no.:8100089453

Current transducer

Parameter	Symbol	Condition	Value	Unit
Primary current	I_p			
Nominal primary current	I_{pn}		± 60	A
Polarity			Bipolar	
Secondary current	I_s			
Nominal secondary current	I_{sn}		± 100	mA
External burden resistor	R_b			
Max.	$R_{b, max}$		20	Ω
Min.	$R_{b, min}$		0	Ω
Current transfer ratio	N		600	
Overload capacity				
Max. nondestructive overload	$I_{p, max}$	@ 0.1s	500	% I_{pn}
Min. overload trip value	$I_{p, trip}$		110	% I_{pn}
DC accuracy				
Offset				
Initial	I_{so}		< 250	ppm
Drift vs. Temp.	$I_{so, temp}$		< 2.5	ppm / K
Drift vs. Time	$I_{so, time}$		< 2.5	ppm / month
Drift vs. supply voltage	$I_{so, supply}$		< 2.5	ppm / %
Linearity				
Deviation	X_d		< 20	ppm
Output noise	$I_{s, noise}$			
		0 - 10Hz	< 1	ppm (RMS)
		0 - 100Hz	< 1	ppm (RMS)
		0 - 1kHz	< 4	ppm (RMS)
		0 - 10kHz	< 6	ppm (RMS)
		0 - 50kHz	< 15	ppm (RMS)

Ultrastab 867-60I

PRELIMINARY DRAFT: 08.07.2008

Part no.:8100089453

Current transducer

Parameter	Symbol	Condition	Value	Unit
Dynamic response Slew rate	dI/dt	10 - 90%	> 25	A / μ S
Bandwidth ± 3 dB	f		0 - 100	kHz
Busbar noise Measured on primary cable, one turn	U_b	DC - 50kHz	< 30	μ V RMS
Busbar free zone Length Radius	l r		40 40	mm mm
Test voltages Busbar to GND	$V_{t, b}$		2000	VAC RMS
Power supply Supply voltage Maximum current consumption	V_s I_{max}	$\pm 5\%$	± 15 ± 150	V mA
Operating environment Temperature Humidity	T_a RH_a	Noncondensing	10 - 50 20 - 80	$^{\circ}$ C %RH
Storage environment Temperature Humidity	T_s RH_s	Noncondensing	-20 - 85 20 - 80	$^{\circ}$ C %RH

Ultrastab 867-60I

PRELIMINARY DRAFT: 08.07.2008

Part no.:8100089453

Current transducer

Parameter	Symbol	Condition	Value	Unit
Mechanical dimension				
Width	W		93	mm
Height	H		78	mm
Depth	D		47	mm
Weight (approx.)	m		0.3	kg
Inner hole diameter	O		26	mm

Notes:

- 1: All ppm figures refer to nominal current
- 2: Specifications is subject to change without notice

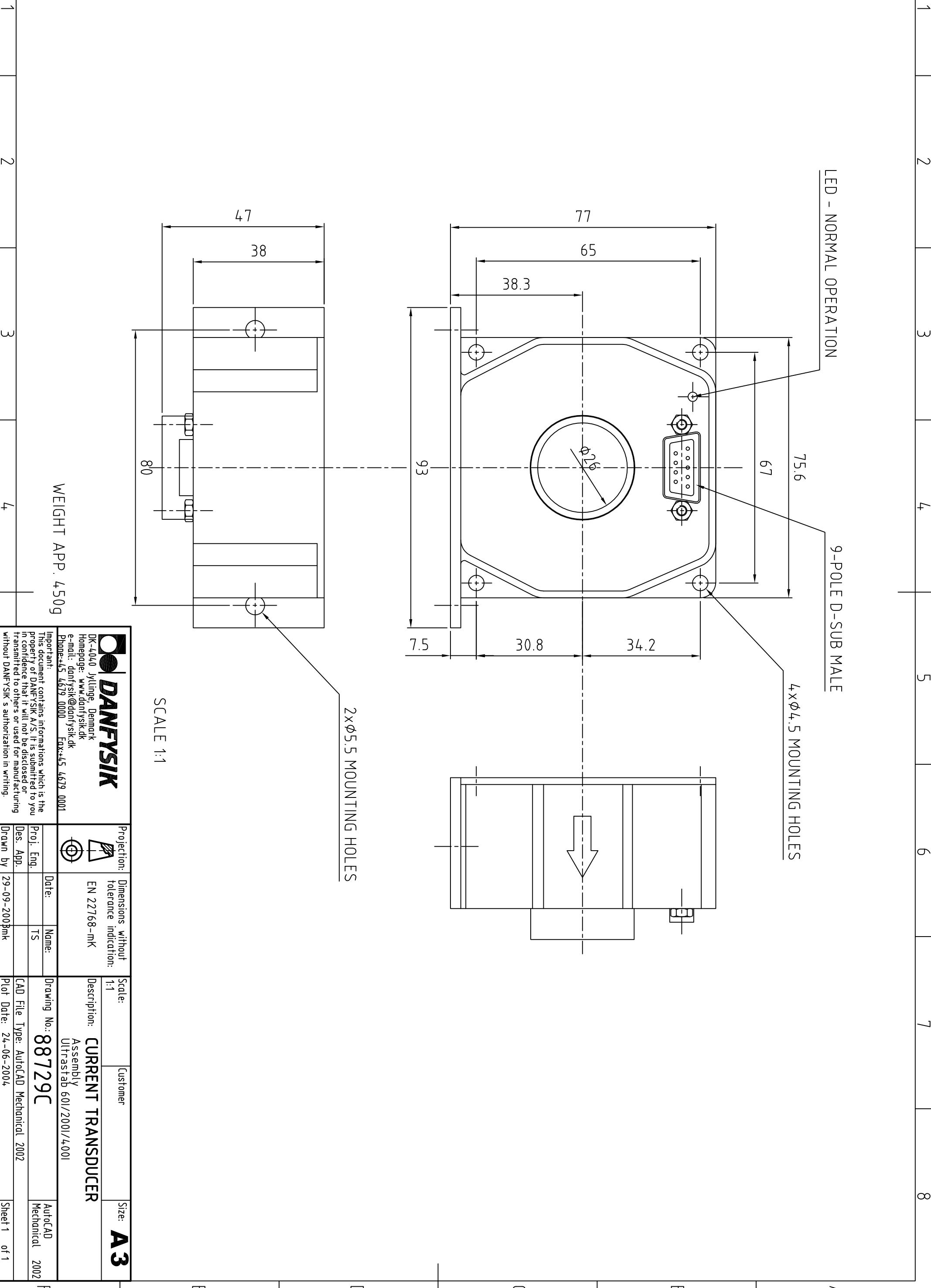

SCALE 1:1

WEIGHT APP. 450g

<p>DANFYSIK DK-4040 Jyllinge, Denmark Homepage: www.danfysik.dk e-mail: danfysik@danfysik.dk Phone:+45 4679 0000 Fax:+45 4679 0001</p>		<p>Projection: </p> <p>Dimensions without tolerance indication: EN 22768-mk</p>	<p>Scale: 1:1</p> <p>Description: CURRENT TRANSDUCER Assembly Ultrastab 60I/200I/400I</p>	<p>Customer:</p>	<p>Size: A3</p>
<p>Important: This document contains informations which is the property of DANFYSIK A/S. It is submitted to you in confidence that it will not be disclosed or transmitted to others or used for manufacturing without DANFYSIK's authorization in writing.</p>	<p>Des. App. </p>	<p>Date:</p>	<p>Drawing No.: 88729C</p>	<p>CAD File Type: AutoCAD Mechanical 2002</p>	<p>AutoCAD Mechanical 2002</p>
	<p>Drawn by</p>	<p>29-09-2003mk</p>	<p>Plot Date: 24-06-2004</p>	<p>Mechanical 2002</p>	<p>Sheet 1 of 1</p>

ULTRASTAB 867- 60I INSTALLATION

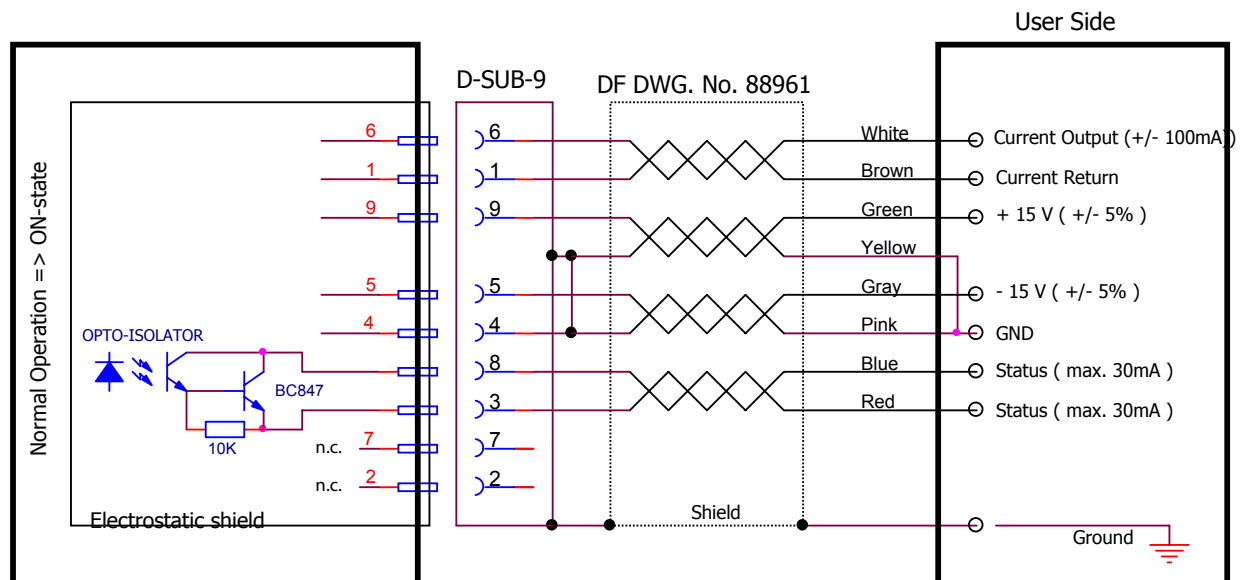

Pin configuration for 9 pole D - SUB :

Pin 1	Current return	Pin 6	Current output
Pin 2	N.C.	Pin 7	N.C.
Pin 3	Normal operation status	Pin 8	Normal operation status
Pin 4	GND	Pin 9	+15V supply voltage
Pin 5	-15V supply voltage	House	Electrostatic shield

Electrical specification - power :

Supply voltage pin 9 to pin 4	:	+ 15 V +/- 5 %
Supply voltage pin 5 to pin 4	:	- 15 V +/- 5 %
Supply current pin 9 to pin 4	:	+ 70 mA + output current (100 mA nom.)
Supply current pin 5 to pin 4	:	- 70 mA - output current (100 mA nom.)
Test voltage secondary (pin 4) to shield	:	200 VDC

Electrical specification – status signal :

Fault level (off-state)	:	$I_p > 110 \%$
Max. voltage pin 8 to pin 3 , off-state	:	45 V
Max. current pin 8 to pin 3 , on-state	:	30 mA
Reverse voltage pin 8 to pin 3 , off-state	:	5 V
On-voltage pin 8 to pin 3 , $I = 5 \text{ mA}$:	1 V max.
Test voltage secondary (pin 4) to pin 8	:	300 VDC

Accessories :

- 9 pole D-sub plug with 2m shielded cable (Part No. 65889610)
- 5 Ω Burden Resistor (2 x 10 Ω) , 0.05% , $T_c < 3 \text{ ppm}/^\circ\text{C}$

Manufacturer: Danfysik A/S • Møllehaven 31 • DK-4040 Jyllinge • Denmark
 Tel. +45 4679 0000 • Fax +45 4679 0001 • danfysik@danfysik.dk • www.danfysik.com

North America Distributor: GMW Associates • 955 Industrial Rd • San Carlos, CA 94070 • USA
 Tel. +1 650 802 8292 • Fax +1 650 802 8292 • sales@gmw.com • www.gmw.com