



ULTRASTAB 867-400I Precision Current Transducer

The Ultrastab 867-400I Current Transducer is a model in the Ultrastab Current Transducer program.

It is the second generation of current transducers from Danfysik with transducer head and SMD based electronics integrated in one assembly.

The 867-400I features a new zero flux detector construction with extreme low noise feed back, compact in size and competitive in price.

It ranges 0-400A from DC to 100kHz with a temperature drift lower than 0.5ppm/°C. Powered with $\pm 15V$ it produces an analog output current of 200mA at 400A primary current.

Output noise and noise feed back to the main conductor are both extremely low, and electrostatic shielding ensures maximum immunity against external electrostatic fields.

The 867 features

- Bandwidth DC to 100kHz
- Linearity better than 3ppm
- Traceable absolute calibration
- Temperature drift less than 0.1ppm/°C
- Bipolar - up to 400A primary current with 200mA output current
- Low noise on output signal
- Noise feed-back to main conductor $< 5\mu V$
- Resolution better than 0.05ppm

Applications

- Feed back element in high performance gradient amplifiers
- Feed back element in precision current regulated power supplies

North American Distributor: GMW Associates • 955 Industrial Rd • San Carlos, CA 94070 • USA
Tel +1 650 802 8292 • Fax +1 650 802 8298 • sales@gmw.com • www.gmw.com

Working principle

The Ultrastab 867 Current Transducer system is a unique design, based on the zero flux principle for galvanically isolated current measurement.

The Ultrastab 867 has a built-in free-running oscillator, which drives the zero flux detector circuitry.

With the primary current conductor through the transducer head center hole and current flowing, the electronics will generate a current in the built-in compensation winding counterbalancing the primary ampere turns.

A very sensitive and extremely low noise detector circuit will detect when zero flux is obtained, and an analog current signal will be generated at the output terminals in direct proportion to the primary current.

Installation

The Ultrastab 867-400I unit is fully self-contained, requiring only $\pm 15V$ voltage supply. All connections via a 9-pole D-sub socket.

It can be installed in any orientation and has a high immunity against external magnetic and electrostatic fields.

With the 867 delivered with the standard transfer ratio of 2000:1, a 400A primary current will generate a 200mA compensation current. Wired up with a 2.5 Ohm Burden resistor, an 0.5V analog output signal will be available.

If e.g. a max. 300A primary current is to be measured, the Burden resistor can be increased to 6.6 Ohm producing an 1V analog signal. From Fig. 1 on the attached installation data sheet it can be seen that the 867-400I can operate with higher resistance values of Burden resistors, but in order to get the best performance out of the Burden resistors, we recommend to keep the power loss as low as possible.

Standard features

The Ultrastab 867 is equipped with opto insulator for status interlock reading. A LED on the front shows NORMAL OPERATION i.e. interlock status ok.

The Ultrastab 867 has a built-in scanning/lock in circuit for automatic recovery to normal operation after overload condition.

Accessories

- 9-pol D-sub with 2m shielded cable
- 2.5 Ohm Burden resistor (4 x 10 Ohm //), 0.1%, $T_c < 3\text{ppm}/^\circ\text{C}$
- $\varnothing 25$ busbar

Ordering information standard

- 867-400I current transducer
- 866/867-BR2,5 Burden resistor
- 866/867-SC, 2m shielded cable
- 866/867-BB bus bar

Ultrastab 867-400I

Last update: 15.03.2007

Current transducer

Parameter	Symbol	Condition	Value	Unit
Primary current	I_p		± 400	A
Nominal primary current				
Polarity			Bipolar	
Secondary current	I_s		± 200	mA
Nominal secondary current				
External burden resistor	R_b		2.5	Ω
Max.		$R_{b, \max}$		
Min.	$R_{b, \min}$		0	Ω
Current transfer ratio	N		2000	
Overload capacity				
Max. nondestructive overload	$I_{p, \max}$	@ 0.1s	500	% I_{pn}
Min. overload trip value	$I_{p, \text{trip}}$		110	% I_{pn}
DC accuracy				
Offset				
Initial	I_{so}		< 30	ppm
Drift vs. Temp.	$I_{so, \text{temp}}$		< 0.5	ppm / K
Drift vs. Time	$I_{so, \text{time}}$		< 1	ppm / month
Drift vs. supply voltage	$I_{so, \text{supply}}$		< 3	ppm / %
Linearity				
Deviation	X_d		< 3	ppm
Output noise	$I_{s, \text{noise}}$	0 - 10Hz	< 0.05	ppm (RMS)
		0 - 100Hz	< 0.5	ppm (RMS)
		0 - 1kHz	< 1	ppm (RMS)
		0 - 10kHz	< 3	ppm (RMS)
		0 - 50kHz	< 5	ppm (RMS)

Ultrastab 867-400I

Last update: 15.03.2007

Current transducer

Parameter	Symbol	Condition	Value	Unit
Dynamic response				
Slew rate	dI/dt	10 - 90%	> 80	A / μ S
Bandwidth				
± 1 dB	f	<0.5%I _{pn}	10	kHz
± 3 dB		< 0.5% I _{pn}	100	kHz
Busbar noise				
Measured on primary cable, one turn	U _b	DC - 50kHz	< 5	μ V RMS
Busbar free zone				
Length	l		150	mm
Radius	r		75	mm
Test voltages				
Busbar to GND	V _{t, b}		5000	VAC RMS
Power supply				
Supply voltage	V _s	$\pm 5\%$	± 15	V
Maximum quiescent current	I _q		± 70	mA
Maximum current consumption	I _{max}		± 270	mA
Operating environment				
Temperature	T _a		10 - 50	$^{\circ}$ C
Humidity	RH _a	Noncondensing	20 - 80	%RH
Storage environment				
Temperature	T _s		-20 - 85	$^{\circ}$ C
Humidity	RH _s	Noncondensing	20 - 80	%RH

Ultrastab 867-400I

Last update: 15.03.2007

Current transducer

Parameter	Symbol	Condition	Value	Unit
Mechanical dimension				
Width	W		93	mm
Height	H		78	mm
Depth	D		47	mm
Weight (approx.)	m		0.3	kg
Inner hole diameter	O		26	mm

Notes:

- 1: All ppm figures refer to nominal current
- 2: Specifications are subject to change without notice

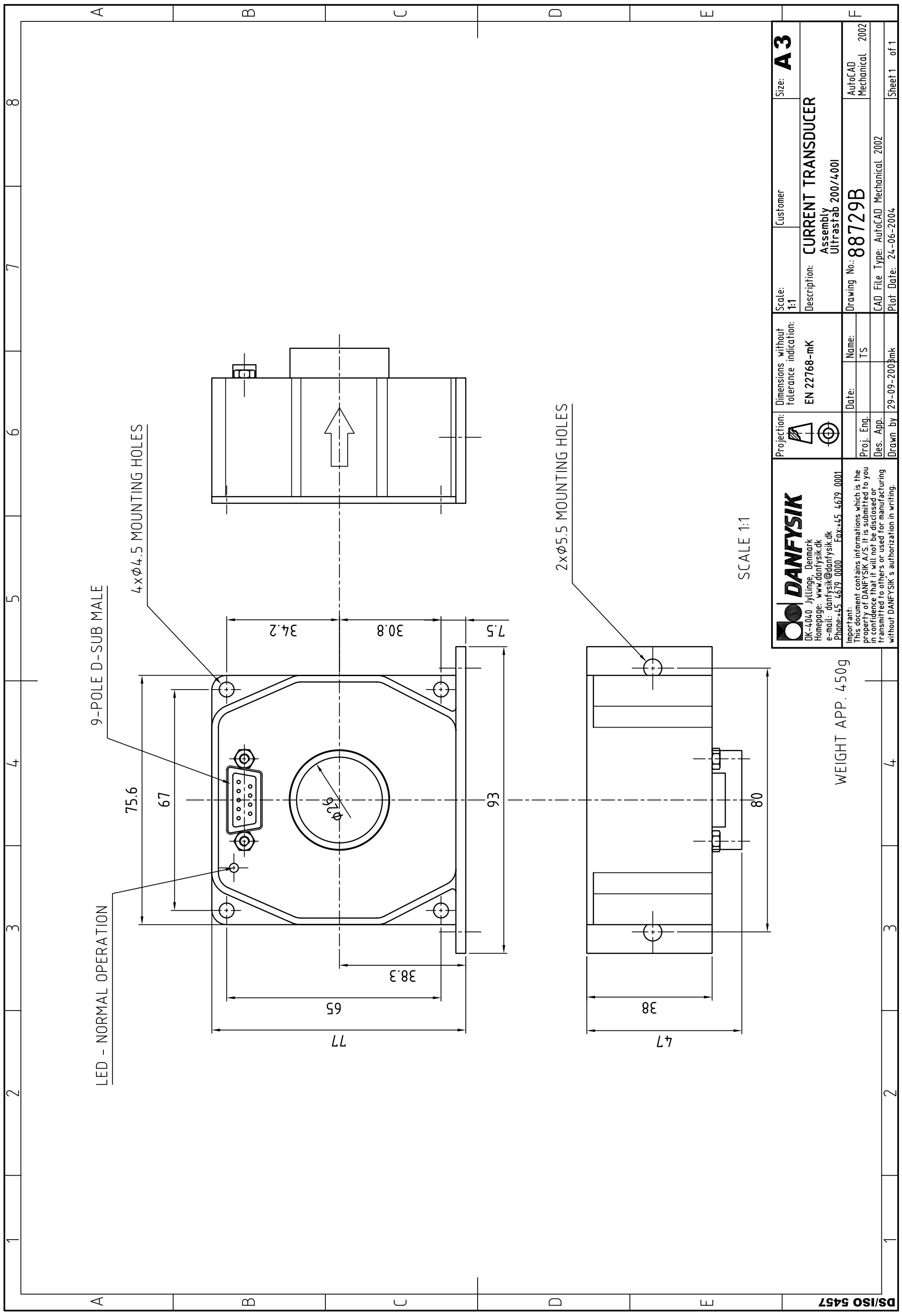

<p>DK-4040 Jyllinge, Denmark Homepage: www.danfysik.dk e-mail: danfysik@danfysik.dk Phone: +45 4679 0000 Fax: +45 4679 0001</p> <p>Important: This document contains information which is the property of DANFYSIK A/S. It is submitted to you in confidence that it will not be disclosed or transmitted to others or used for manufacturing without DANFYSIK's authorization in writing.</p>		Projection: 	Dimensions without tolerance indication: EN 22768-mK	Scale: 1:1	Customer: CURRENT TRANSDUCER Assembly Ultrafab 200/4001	Size: A3
		Date: 29-09-2003mk	Name: TS	Drawing No.: 88729B	CAD File Type: AutoCAD Mechanical. 2002	AutoCAD Mechanical 2002
		Proj. Eng. Des. App.	Drawn by 29-09-2003mk	CAD File Type: AutoCAD Mechanical. 2002	Plot Date: 24-06-2004	Sheet 1 of 1

WEIGHT APP. 450g

ULTRASTAB 867-400I INSTALLATION

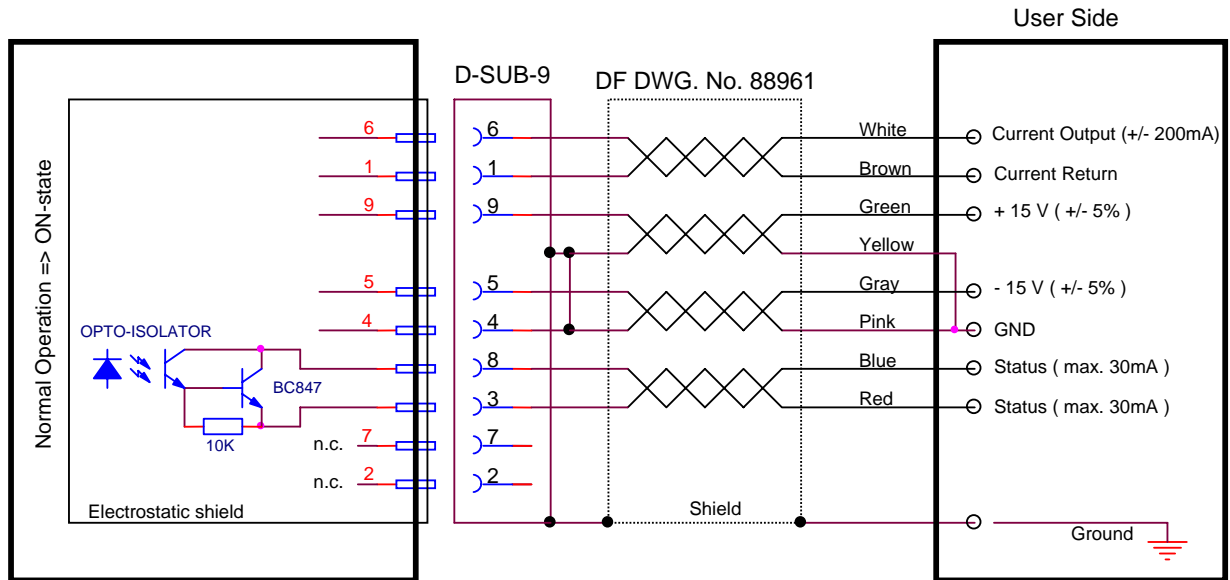

Pin configuration for 9 pole D_SUB :

Pin 1	Current return	Pin 6	Current output
Pin 2	N.C.	Pin 7	N.C.
Pin 3	Normal operation status	Pin 8	Normal operation status
Pin 4	GND	Pin 9	+15V supply voltage
Pin 5	-15V supply voltage	House	Electrostatic shield

Electrical specification - power :

Supply voltage pin 9 to pin 4	:	+ 15 V +/- 5 %
Supply voltage pin 5 to pin 4	:	- 15 V +/- 5 %
Supply current pin 9 to pin 4	:	+ 70 mA + output current (200 mA nom.)
Supply current pin 5 to pin 4	:	- 70 mA - output current (200 mA nom.)
Test voltage secondary (pin 4) to shield	:	200 VDC

Electrical specification – status signal :

Fault level (off-state)	:	$I_p > 110 \%$
Max. voltage pin 8 to pin 3 , off-state	:	45 V
Max. current pin 8 to pin 3 , on-state	:	30 mA
Reverse voltage pin 8 to pin 3 , off-state	:	5 V
On-voltage pin 8 to pin 3 , $I = 5 \text{ mA}$:	1 V max.
Test voltage secondary (pin 4) to pin 8	:	300 VDC

Accessories :

- 9 pole D-sub plug with 2m shielded cable (Part No. 65889610)
- 2.5 Ω Burden Resistor (4 x 10 Ω) , 0.05% , $T_c < 3 \text{ ppm}/^\circ\text{C}$
- \varnothing 25mm busbar

Manufacturer: Danfysik A/S • Møllehaven 31 • DK-4040 Jyllinge • Denmark
 Tel. +45 4679 0000 • Fax +45 4679 0001 • danfysik@danfysik.dk • www.danfysik.com

North America Distributor: GMW Associates • 955 Industrial Rd • San Carlos, CA 94070 • USA
 Tel. +1 650 802 8292 • Fax +1 650 802 8292 • sales@gmw.com • www.gmw.com