

LR-BPM

Log-Ratio BPM Electronics

Beam position measurement
Non-interceptive
Optimal for single-pass short bunches,
Linacs, transfer lines, first turns
Fast-cycling synchrotrons, boosters
Beam charge range > 500
Beam-based center determination

The Log-Ratio Beam Position Monitor (LR-BPM) is an electronics module for fast analog processing of beam pickup signals

Input signals parallel processing allows single-pass position measurement

Bunches at any repetition rate up to 500 MHz. Individual bunches can be distinguished from one another up to 5 MHz repetition.

L-band, S-band, X-band beams can be processed provided bunch groups are short (<3 ns)

±2V X and Y outputs are held until the next bunch when Sample & Hold mode (optional) is activated

Provides log signal from each pickup electrode for computer analysis, with 5 MHz bandwidth.

Beam-based center determination accessory equalizes pickup signals to simulate beam on center

Log-Ratio BPM is plug-compatible with Bergoz' multiplexed BPM

LR-BPM may be custom-built on daughter card for installation on user's DSP mother boards

Cables length matching not critical: pickup signals don't need to be in phase

$$X = -0,00012$$

$$Y = +0,00008$$

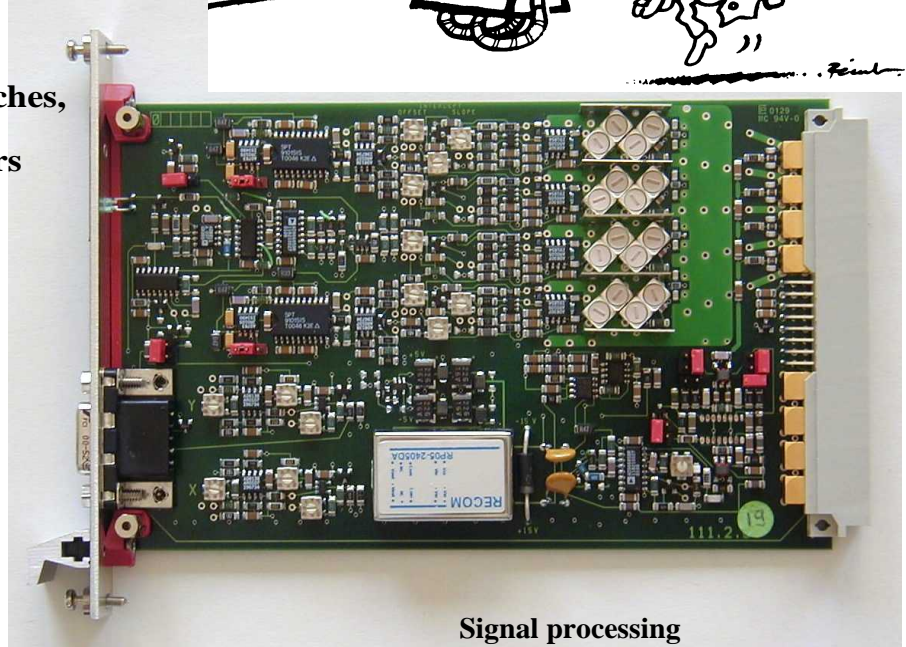
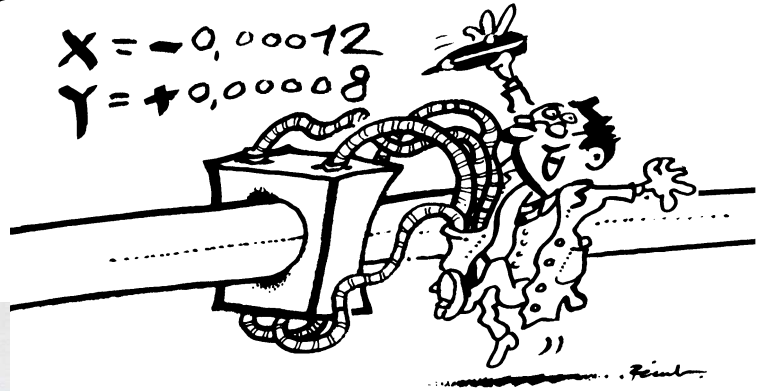

Operating principle

Based on the pioneering work of Robert E. Shafer at Los Alamos Laboratory, the Log-Ratio BPM derives beam position from logarithm of the ratio of opposite pickup signals: $\text{Log}(A/B)$.

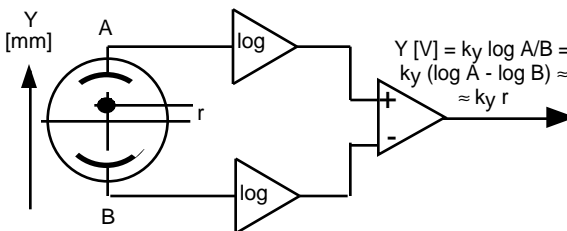

Position measured by this method is more linear, over a wider range, than difference-over-sum.

The position of the beam from rotated pickups:

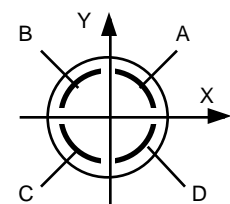

is obtained by axes translation to the vertical resp. horizontal plane by wideband analog circuits.

Signal processing

Signals from the pickups are stretched to produce bursts. This is essential to measure the single pass of a bunch. Four parallel logarithmic amplifiers detect the burst envelopes. Amplifiers' response is log of amplitude. Logs of opposite pickups are subtracted. If pickups are rotated, axes are translated to obtain X and Y positions. The process is all-analog, wideband.

Beam-based center determination

Differences between parallel processing channels can be near-eliminated using the Beam-based center determination accessory. It equalizes opposite pickup signals to simulate beam on center.

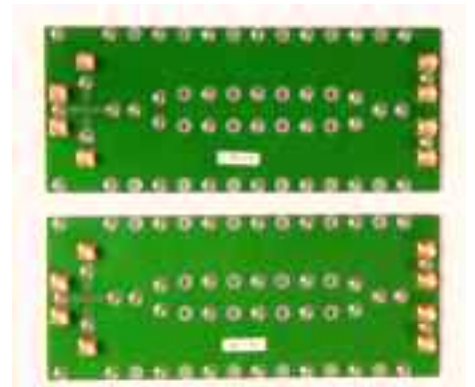

The zero offsets can thus be measured at regular intervals under user's control and deducted from further readings. Signals entering the equalizer must be in phase.

It is controlled by the LR-BPM module, via the input cables. Center determination and beam position measurement can be interleaved.

Block Diagram

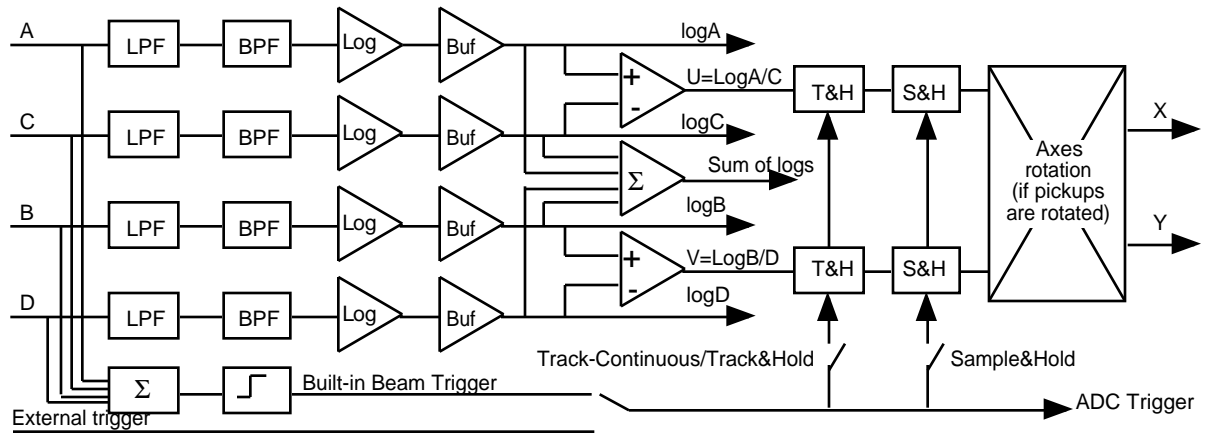

Specifications

Measures from single-pass bunch up to X-band under certain conditions. Below 5 MHz repetition rate, individual position is reported. Above 5 MHz repetition rate, average position is reported, with 5-MHz response. The input filter frequency f determines the acceptable bunch width. Filter frequency f is specified in Ordering Code LR-BPM-xxxMHz. Max. 500 MHz.

Beam intensity range	> 50 dB. Single bunch 30 pC ... 10 nC
Single bunch (or group of bunches)	width $\leq 1 / 2f$ E.g. for $f=50$ MHz: 10ns max width; $f=500$ MHz: 1-ns max width or three 3-GHz bunches
Bunch/group trains	f = repetition rate or multiple of rate. $f_{max}=500$ MHz
Output frequency	<5-MHz rep rate, individual position is measured >5-MHz rep rate, average position is reported with 5-MHz bandwidth
Input signal max.	
Single bunch	10V in 1 ns, 50 Ω
Bunch trains	depends on f . At 500 MHz: +5 dBm, 50 Ω
Outputs	X and Y: -2V...0...+2V, 40mA max Logs of A, B, C, D; Sum of logs: 0...+2V, 40mA max.
X and Y gain	1.5V = 1/2 of aperture radius for orthogonal pickups 1.0V = 1/2 of aperture for rotated pickups
Noise rms	
Single bunch	<3.5 10^{-3} of aperture, e.g. <150 μ m in 20mm radius. below 10 pC ($\approx 6 \cdot 10^7$ e-), increases 20dB/decade
Bunch trains	<2 10^{-3} of aperture, in 0...5 MHz bandwidth, e.g. <100 μ m in 20mm radius Below -40 dBm, increases 20 dB/decade. Decreases with square root of bandwidth: e.g. <15 μ m above -40dBm in 100 kHz in 20mm radius.
Beam intensity position dependence	
On center	Near zero. Can be eliminated by the beam-based center determination accessory
Off-center	Worst case when beam is 6dB off center (e.g. ± 7 mm in a 20mm radius aperture): $\pm 3\%$
Temperature drift	0.6 10^{-3} of aperture per degree, e.g. 25 μ m/K in 20mm radius aperture
Trigger output	>10-ns trigger after single bunch
Power supply	+ 15V, <300 mA; - 15V, <300 mA

Packaging

LR-BPM module is 3U-high x 160mm shielded Euromodule; 20-mm wide. Interchangeable / plug-compatible with Bergoz Instrumentation Multiplexed BPM modules. Both log-ratio and multiplexed BPMs can be installed in same chassis for mixed applications.

LR-BPM can be supplied as a custom-built daughter card for user installation on DSP mother boards.

Beam-based center determination accessory is 160x85x15 mm board with SMAs.

The Log-ratio BPM is developed by Alexander Kalinin, with contributions from Jim Hinkson and Klaus Unser. Based on Robert E. Shafer original concept.

Ordering information

LR-BPM-xxxMHz Log-ratio BPM plug-in module

On-board factory-installed options:

LR-BPM-SH Sample and Hold on X and Y outputs
LR-BPM-TRG Beam Trigger, built-in
LR-BPM-SUM Sum of log (A,B,C,D)
LR-BPM-ABCD Direct Log(A,B,C,D) wideband outputs

Accessories:

BPM-BBC Beam-based center determination. Equalizes the inputs to simulate a centered beam. Requires in-phase pickup signals. User-controlled via the LR-BPM module.
BPM-RFC/xx RF-chassis, $xx \leq 16$ stations
19" rack-mountable 3U-high EMI-RFI-shielded chassis for 100~240V 50~60Hz mains power, features up to 16 stations for any mix of Log-ratio BPM or Multiplexed BPM.
BPM-KIT Table-top test kit.
100~240V 50~60Hz powered kit.
Pickup inputs on SMAs.
Outputs on BNCs and DB15.
BPM-XTD Module extender card.
BPM-SERV/RF RF service module.
Passive module. Brings the pickup signals from the back connectors to front panel BNCs.

Distributors

U.S.A. : GMW Associates
955 Industrial Rd.
San Carlos, CA 94070, U.S.A.
Fax: (650) 802-8298 - Tel.: (650) 802-8292
sales@gmw.com

Japan : REPIC Corporation
28-3 Kita Otsuka 1-Chome
Toshima-ku, Tokyo 170-0004, Japan
Fax: 03-3918-5712 - Tel.: 03-3918-5326
sales@repic.co.jp

Manufacturer

BERGOZ Instrumentation
Espace Allondon Ouest
01630 Saint Genis Pouilly, France
Fax: +33-450.426.643 - Tel.: +33-450.426.642
sales@bergoz.com

