BERGOZ Instrumentation
Espace Allondon Ouest
01630 Saint Genis Pouilly, France
Tel.: +33-450.426.642
Fax: +33-450.426.643



Instrumentation

Visit our web site at
<http://www.bergoz.com>

Baseband Beam Position Monitor User's Manual

Rev. 2.3

Japan:

REPIC Corporation
28-3, Kita Otsuka 1-Chome
Toshima-ku, Tokyo 170-0004
Tel.: 03 - 3918 - 5326
Fax: 03 - 3918 - 5712
sales@repic.co.jp

U.S.A.:

GMW Associates
955 Industrial Road
San Carlos, CA 94070
Tel.: (650) 802-8292
Fax: (650) 802-8298
sales@gmw.com

Record of changes:

- 2.1 Sept. 5, 2007 Page 19 CONNECTORS PINS ALLOCATION Rev.3.1
Correction of error in manual:
SUM, Sum of logs, is on pin 7 of front panel DB9 connector
- 2.2 Oct. 16, 2007 Page 19 CONNECTORS PINS ALLOCATION Rev.3.2
The BB-BPM-ABCD optional coaxial outputs are changed:
LOGA is in b22 (used to be in b31)
LOGB is in b25 (used to be in b28)
LOGC is in b28 (used to be in b25)
LOGD is in b31 (used to be in b22).
Analog ground on c20 is suppressed.
Analog ground on chassis rear panel DB15 pin 3 is suppressed.
Beam Trigger output positive-going is now on:
Pins c19 and c20; pin c20 used to be a ground pin.
Chassis rear panel DB15 pins 2 and 3. Pin 3 used to be a ground.
Beam-based Center Enable is now on pins a13 and b13;
it used to be on pin a13 only.
Correction of error in manual:
Chassis rear panel DB15 pin 14 is not a ground pin.
- 2.3 Nov.2, 2007 Page 19 CONNECTORS PINS ALLOCATION Rev.3.3
Power supply pin changes: Those pins are no longer grounds:
DB9 pin 7; DIN41612M pin c18 and Rear chassis DB15 pin 12.

SUMMARY

Page

INITIAL INSPECTION	2
WARRANTY	2
ASSISTANCE	2
SERVICE & RETURN PROCEDURES	2
YOU JUST RECEIVED A BEAM POSITION MONITOR... ..	3
QUICK CHECK	4
Setup.....	4
Beam displacement.....	5
Explore the dynamic range.....	7
ADVANCED CHECK.....	8
Setup.....	8
X and Y outputs for single pass.....	11
ALGORITHM, SENSITIVITY & POLARITY.....	12
Orthogonal pickups.....	12
Rotated pickups.....	12
ON-BOARD ADJUSTMENTs.....	13
Baseband Beam Position Monitor board.....	14
User's adjustments.....	14
BB-BPM PRINCIPLE OF OPERATION.....	15
BLOCK DIAGRAM.....	15
PERFORMANCE.....	16
SIGNALS.....	17
BPM CABLES LAYOUT, INSTALLATION.....	18
CONNECTORS PINS ALLOCATION Rev.3.0	19
ACCESSORIES.....	20
Table-top test kit.....	20
Card extender.....	20
RF service module.....	20
Chassis.....	21
SPECIFICATIONS.....	21
BPM MODULE REAR CONNECTOR.....	22
SCHEMATICS & BOARD LAYOUT.....	23
ACKNOWLEDGEMENT.....	23

INITIAL INSPECTION

It is recommended that the shipment be inspected immediately upon delivery. If it is damaged in any way, contact Bergoz Instrumentation or your local distributor. The content of the shipment should be compared to the items listed on the invoice. Any discrepancy should be notified to Bergoz Instrumentation or its local distributor immediately. Unless promptly notified, Bergoz Instrumentation will not be responsible for such discrepancies.

WARRANTY

Bergoz Instrumentation warrants its beam monitors to operate within specifications under normal use for a period of 12 months from the date of shipment. Spares, repairs and replacement parts are warranted for 90 days. Products not manufactured by Bergoz Instrumentation are covered solely by the warranty of the original manufacturer. In exercising this warranty, Bergoz Instrumentation will repair, or at its option, replace any product returned to Bergoz Instrumentation or its local distributor within the warranty period, provided that the warrantor's examination discloses that the product is defective due to workmanship or materials and that the defect has not been caused by misuse, neglect, accident or abnormal conditions or operations. Damages caused by ionizing radiations are specifically excluded from the warranty. Bergoz Instrumentation and its local distributors shall not be responsible for any consequential, incidental or special damages.

ASSISTANCE

Assistance in installation, use or calibration of Bergoz Instrumentation beam monitors is available from Bergoz Instrumentation, 01630 Saint Genis Pouilly, France. It is recommended to send a detailed description of the problem by fax.

SERVICE PROCEDURE

Products requiring maintenance should be returned to Bergoz Instrumentation or its local distributor. Bergoz Instrumentation will repair or replace any product under warranty at no charge. The purchaser is only responsible for transportation charges.

For products in need of repair after the warranty period, the customer must provide a purchase order before repairs can be initiated. Bergoz Instrumentation can issue fixed price quotations for most repairs. However, depending on the damage, it may be necessary to return the equipment to Bergoz Instrumentation to assess the cost of repair.

RETURN PROCEDURE

All products returned for repair should include a detailed description of the defect or failure, name and fax number of the user. Contact Bergoz Instrumentation or your local distributor to determine where to return the product. Returns must be notified by fax prior to shipment.

Return should be made prepaid. Bergoz Instrumentation will not accept freight-collect shipment. Shipment should be made via United Parcel Service, DHL or Federal Express. Within Europe, the transportation service offered by the Post Offices "EMS" (Chronopost, Datapost, etc.) can be used. The delivery charges or customs clearance charges arising from the use of other carriers will be charged to the customer.

YOU JUST RECEIVED A BEAM POSITION MONITOR

This manual applies to the Baseband BPM only: BB-BPM
Earlier, this instrument was called Log-ratio BPM with Baseband option: BB-BPM/BB.
Other models, e.g. "BPM", "MX-BPM", "BB-BPM", "VF-BPM" are described in other manuals.

The Baseband BPM system includes:

Description

- Baseband BPM electronics module
where XX-XX MHz is the operating frequency range
- Direct A,B,C,D wideband outputs, option
This option is mounted on the BB-BPM electronics module.

Order code

BB-BPM-XX-XXMHz
BB-BPM-ABCD

Accessories

- 19" chassis with power supply
- Table-top test kit with power supply
- 3U-Card extender with coaxial contacts
- RF service module with four front-panel BNC
- TTL commands service module
with front-panel DB9 and DB15 connectors

BPM-RFC/X, X = BPM stations number
BPM-KIT
BPM-XTD
BPM-SERV/RF
BPM-SERV/CMD

Check the fuse configuration, that it corresponds to your national regulations.

The table-top test kit does not have any fuse.

The 19" BPM-RFC chassis fuse compartment is configured at the time of shipment according to its destination:

- North America: mains ground wire unfused.
- All other destinations: both mains wires are fused.

To verify which fuse configuration is installed on your chassis, pull out the removable fuse block, using a small screwdriver.

- The unfused ground configuration has a shorting bar and a 2A 6x32 fuse.
- The configuration with both AC lines fused is equipped with two 2A 5x20 fuses.

To change this configuration, unscrew the fuse holder off the fuse block, flip the holder over and screw it back onto the fuse block. Insert the following fuses:

- For unfused ground configuration: one 2A 6x32 fast fuse.
- For both AC lines fused configuration: two 2A 5x20 fast fuses.

The power supplies are autoranging from 98V...264V.

QUICK CHECK

You can check immediately that your BB-BPM system is working.

Setup

If you have the table-top test kit (BPM-KIT), use the following set-up:

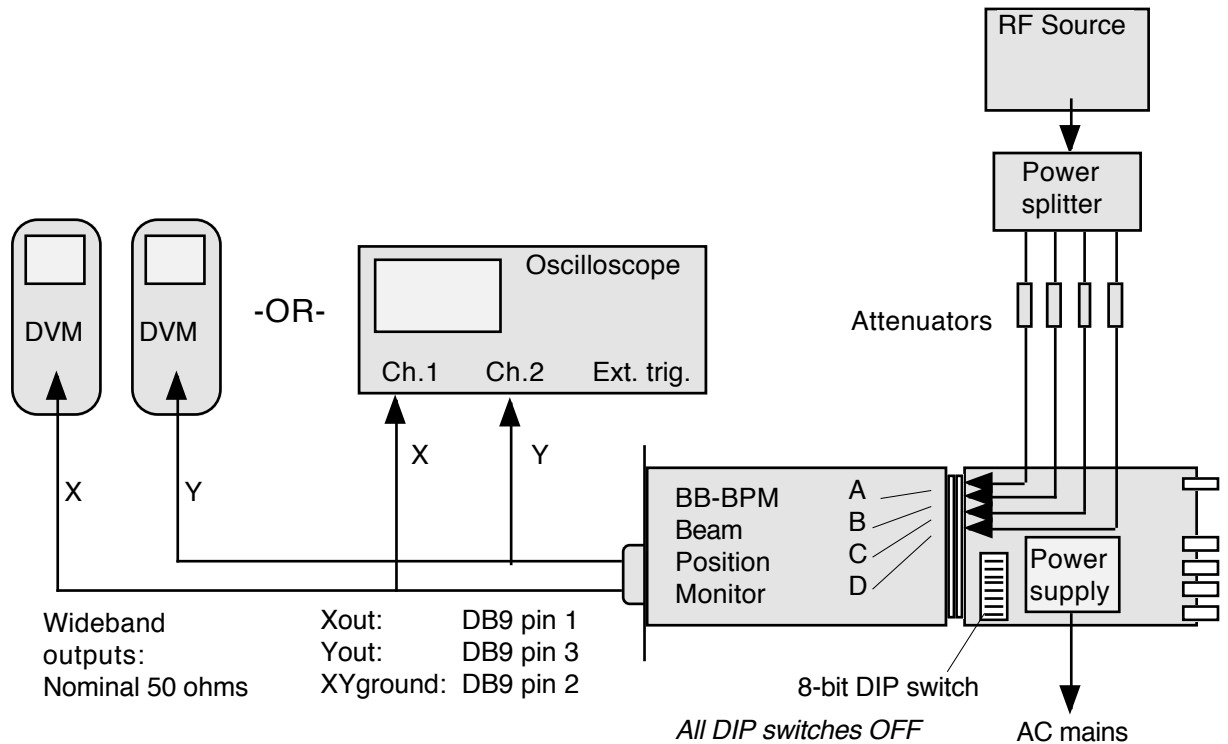

If you have a 19" chassis (BPM-RFC/X), use the following set-up:

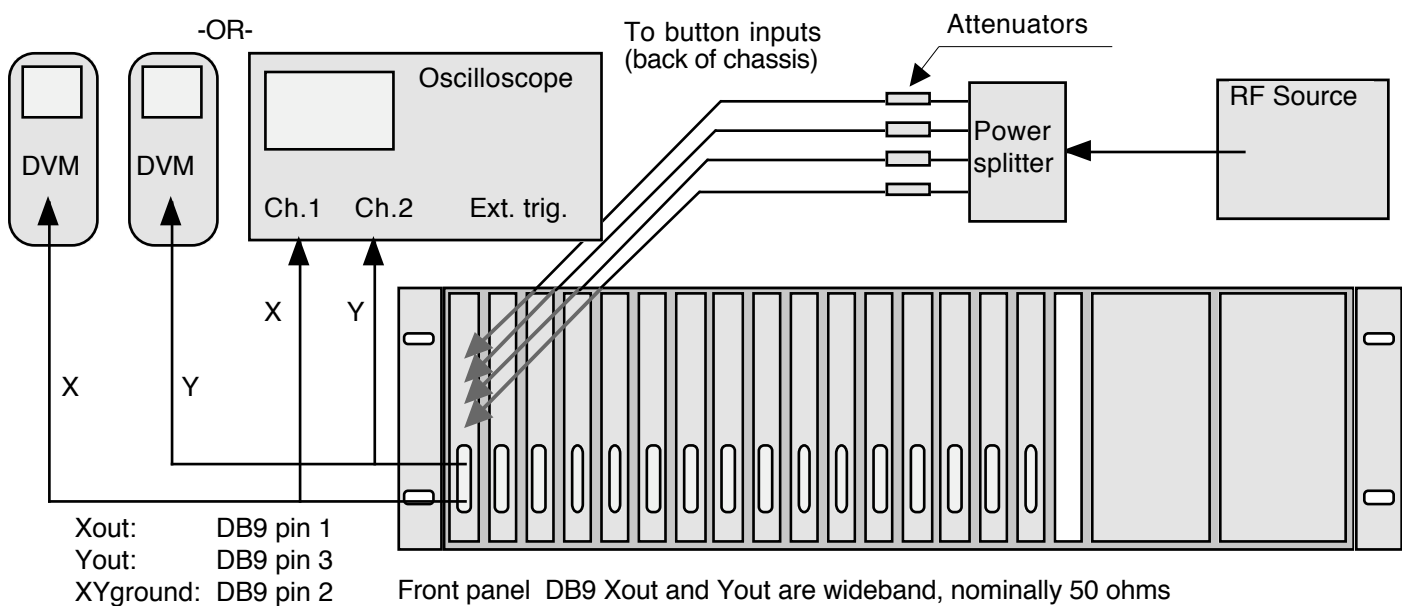

QUICK CHECK (Cont'd)

To display X and Y signals, you can use either two DVMs, or an oscilloscope. The front-panel DB9 outputs are 50 ohms nominal impedance. Attach the equipment together as shown above.

Set the DVMs on Volt-DC, or the oscilloscope on:
Time base on 0.2 ms / div., free running,
Channel 1 to Xout signal, sensitivity 0.2 V / div.
Channel 2 to Yout signal, sensitivity 0.2 V / div.

Set the RF source within the BB-BPM operating frequency range.
E.g. set to 5 MHz to test BB-BPM/1-10MHz, i.e. "mid-range".
Amplitude ca. -10 dBm.

Use 4 similar attenuators, each 3 dB. The same test can be done with 5 and 10 dB.
Please note that attenuators are seldom more precise than ± 0.1 dB. This will be reflected upon the BB-BPM X and Y readings.

*Please note that signals applied to BB-BPM inputs will be attenuated by the 4-way splitter:
Transformer-type 4-way splitters typically attenuate by 7dB,
4-way resistive splitters, or cascaded 2-way splitters attenuate by 12dB.*

Connect to Test Kit or 19" BPM-RFC chassis to AC mains, the DVM (or oscilloscope) will display X and Y values.
If the RF signals applied to all four BB-BPM inputs were exactly equal, and if the BB-BPM module were perfect, the values of X and Y would be exactly 0 Volt.
This is generally not the case, X and Y will be many 10s or even 100s of millivolts off.

You can determine how much of this offset is caused by attenuator inequality:
Swap the attenuators A and C, then B and D and observe the offset change.

You can determine how much of this offset is caused by power splitter imbalance:
Instead of connecting attenuator A to power splitter output 1, connect it to output 3 and connect attenuator C to output 1.
Do the same for attenuators B and D with power splitter outputs 2 and 4.

The next tests will consist of:

- Simulating beam displacements of 6 dB, 10 dB and 14 dB
- Exploring the BB-BPM dynamic range by varying the RF source output power.

Beam displacement

The RF source output power should be in the range -10dBm ... -35 dBm

The BB-BPM on-center sensitivity is factory-set to 55.5 mV per dB of signal difference between opposite pickups. For pickups with small angle (e.g. buttons), 6 dB corresponds to beam displacement equal to 1/6 of vacuum chamber radius. As the beam goes off center, this sensitivity becomes lower due to the algorithm $X = \text{Log}(A/C)$. Please consider that the pickup sensitivity becomes *higher* as the beam goes off center, and one non-linearity tends to compensate the other.

Modules BB-BPM are manufactured in two versions:

- For orthogonally placed pickups: up, down, left and right
- For rotated pickups: upper-right, upper-left, lower-left and lower-right

QUICK CHECK Beam displacement (Cont'd)

Before simulating a beam displacement, start by noting the X and Y zero offsets, using four equal attenuators:

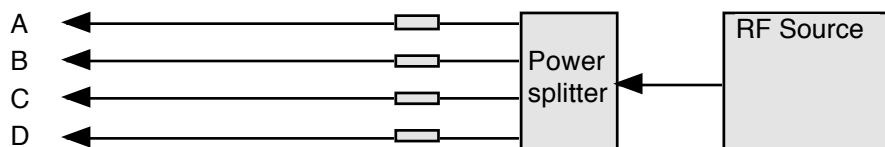

Then simulate the displacement by removing an attenuator from one input and inserting it in the opposite input: A \leftrightarrow C, and B \leftrightarrow D. Example:

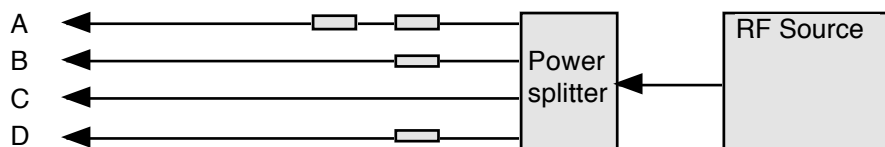

Attenuator C is removed from input C, and added to input A, thus simulating a displacement of the beam towards C (stronger signal on C pickup).

The following combinations can be tried, yielding the X and Y values listed here.

Please note these are *displacements*. Take the zero offsets due to power splitter imbalance and attenuators inequality into consideration.

Input	Attenuators	Equivalent displacement	Rotated pickups	Orthogonal pickups
A	3 + 3	1/6 of radius towards C		
B	3		X = -0.245 V	X = -0.347 V
C	0		Y = -0.245 V	Y = 0 V
D	3	<i>(button pickups << chamber diameter)</i>		
A	3 + 3	1/6 of radius towards C		
B	3 + 3	1/6 of radius towards D	X = 0 V	X = -0.347 V
C	0		Y = -0.490 V	Y = -0.347 V
D	0	<i>(button pickups << chamber diameter)</i>		
A	5 + 5	1/4 of radius towards C		
B	5		X = -0.407 V	X = -0.576 V
C	0		Y = -0.407 V	Y = 0 V
D	5	<i>(button pickups << chamber diameter)</i>		
A	5 + 5			
B	5 + 5		X = 0 V	X = -0.576 V
C	0		Y = -0.814 V	Y = -0.576 V
D	0	<i>(button pickups << chamber diameter)</i>		
A	10 + 7	1/3 of radius towards C		
B	10		X = -0.570 V	X = -0.806 V
C	3		Y = -0.570 V	Y = 0 V
D	10	<i>(button pickups << chamber diameter)</i>		

QUICK CHECK Beam displacement (Cont'd)

Note. The above voltages are representations of the algorithms:

$X = K_X \text{Log}(A/C)$ and $Y = K_Y \text{log}(B/D)$ for orthogonal pickups, and

$X = K_X (\text{Log}(A/C) + \text{Log}(B/D)) \cos \alpha$, and $Y = K_Y (-\text{Log}(A/C) + \text{Log}(B/D)) \sin \alpha$ for rotated pickups.

Where: α is the tilt angle of the pickups,

K_X and K_Y are set to 1.1513 Volts

Note: This value was chosen because it corresponds to a difference-over-sum ratio equal to 1 V, for small amplitude displacements off-center. E.g. 0.001 V for 0.005 x R.

To maintain the condition $A+C = B+D$ when two attenuators are cascaded in one input, their attenuation should be increased. E.g. 3+3 dB should really be ~6.5 dB with ~0.5 dB in opposite input. 5+5 dB should really be ~11.4 dB and 1.4 dB in opposite input, 10+10 dB should really be ~25d dB and ~5 dB in opposite input.

Explore the dynamic range

Set the input attenuators is such way that X and Y are off center.

Vary the power from the RF source to simulate beam intensity variations.

Explore the range from +7 dBm down to -70 dBm.

Remember that 4-way transformer-type splitters absorb typically 7 dB and resistive splitters absorb 12 dB.

While the RF source output power is changed, observe the intensity dependence of X and Y outputs on the voltmeters. The X and Y output voltages vary with input power applied to the BB-BPM inputs:

This plot is taken with an BB-BPM configured for orthogonal pickups

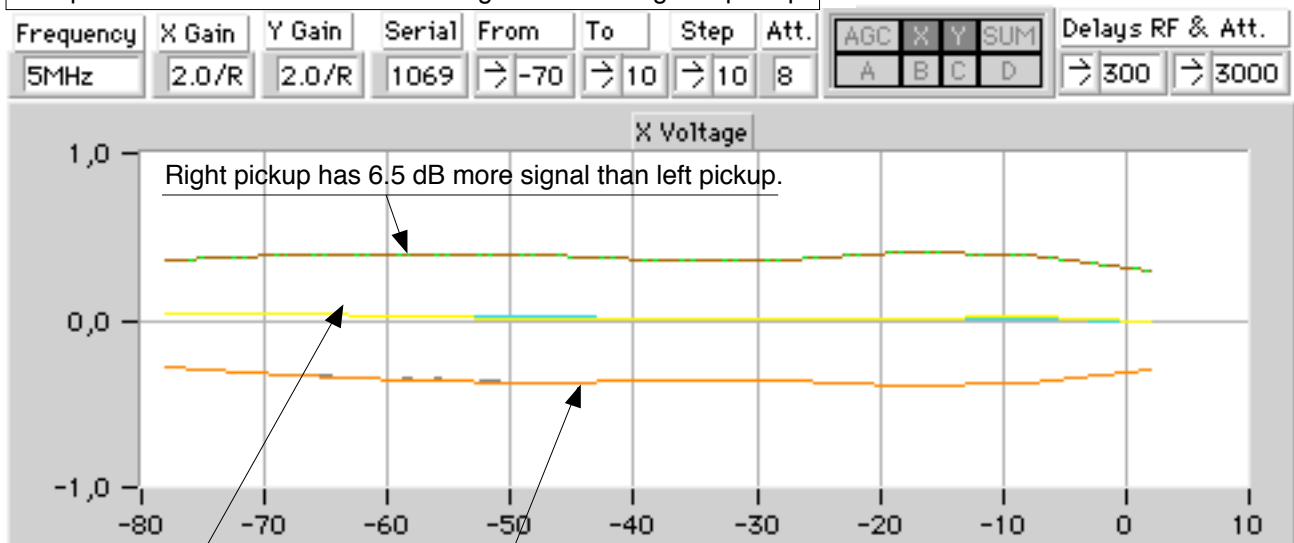

Three traces superimposed:

All inputs equal

Top pickup has 6.5 dB more signal than bottom pickup

Bottom pickup has 6.5 dB more signal than top pickup

ADVANCED CHECK

Before performing the advanced check, it is recommended to get familiar with the Baseband BPM in CW (Continuous Wave) mode as described in earlier chapter "Quick Check". After the initial setup, the checking procedure is the same.

Advanced check will make you familiar with the BB-BPM behavior in single pass mode:

- Select a pulse generator capable of making short pulses with ca. 1nC charge in 50 ohms.

The generator output pulse length should not exceed $T/2$, where T is the period of the the BB-BPM operating frequency.

Example: BB-BPM/1-10MHz. Shortest period = 100ns, the pulse length should not exceed 50 ns.

If 50 ns is chosen, pulse amplitude would be 1V in 50 ohms, to make it 1 nC.

The examples hereafter use 1-ns pulses and 50V amplitude from a mercury pulse generator.

Setup

Using the BPM-KIT Table-top test kit:

Remove the BB-BPM cover shield as described in the On-board adjustments chapter.

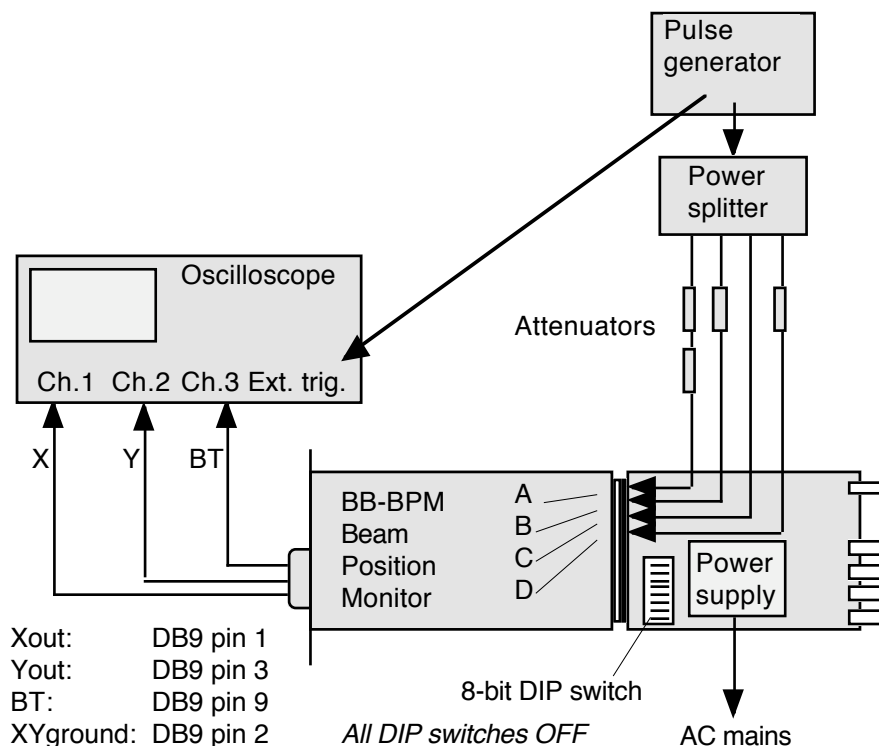

ADVANCED CHECK Setup (Cont'd)

Using a 19" BPM-RFC chassis:

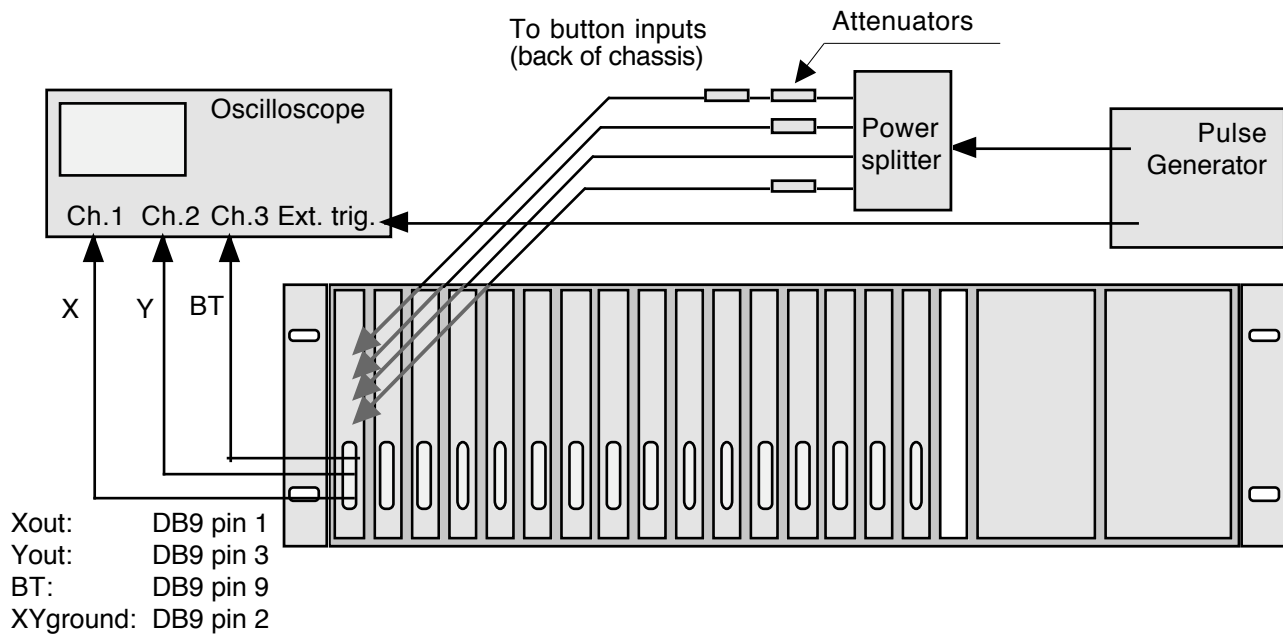

Remove the BB-BPM cover shield as described in the Quick Check.
Place the BB-BPM module on a card extender type BPM-XTD.

Use an asymmetrical combination of attenuators to simulate beam off center.

Start the pulse generator and look for the Beam Trigger signal on the oscilloscope.

Observe the signals on the BB-BPM board with a high-impedance probe. It can be 500-ohm, or -20dB high-Z.

ADVANCED CHECK Setup (Cont'd)

With the probe, take the signal "LogA" off the BB-BPM board:

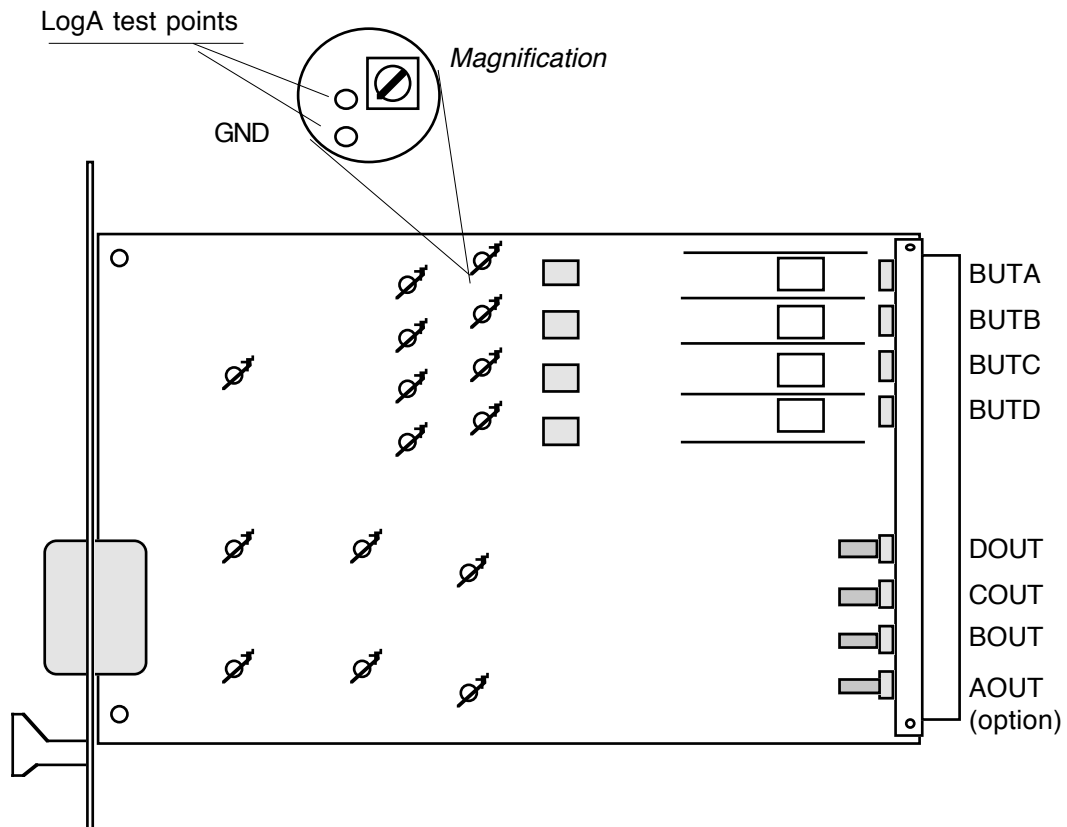

The signals on the oscilloscope will look like:

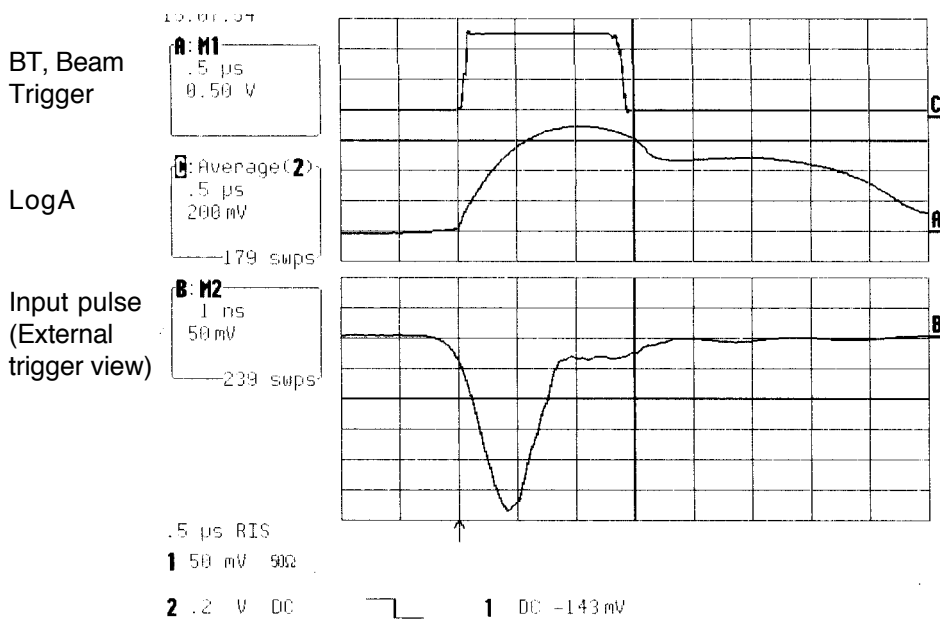

Observe the Beam Trigger BT rising \sim 1 μ s before the apex of LogA.

ADVANCED CHECK (Cont'd)

X and Y output signals for single pass

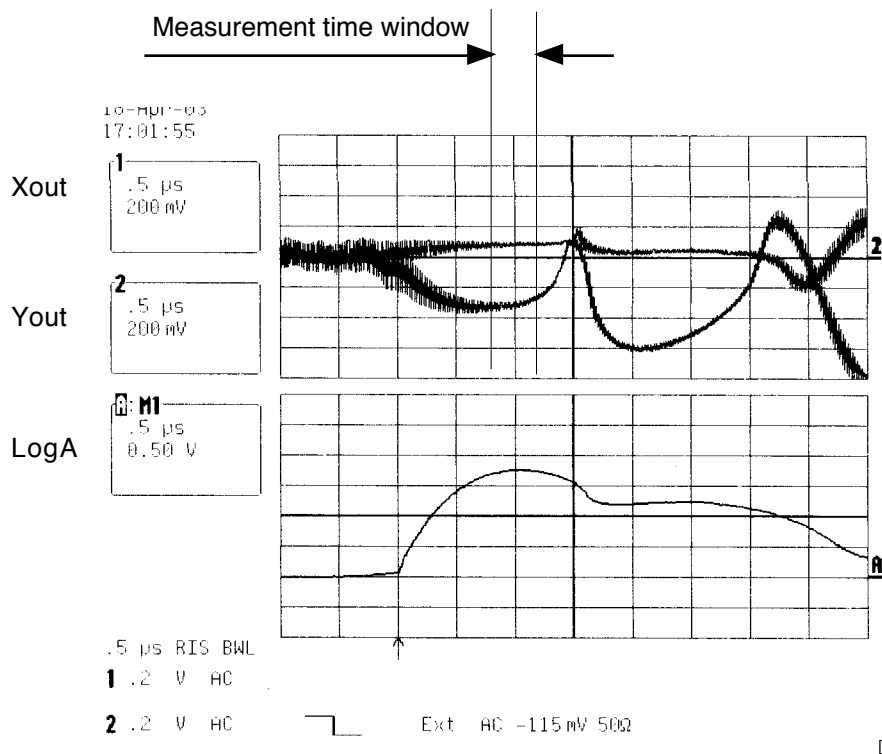

Observe the Xout and Yout signals represent X/Y positions for ~500 ns about LogA pulse apex. LogA apex is itself ~1 us after Beam Trigger rising edge.

Observe the signals Xout and Yout are very noisy before the pulse is applied. It is a characteristics of the logarithmic representation of large variations.

Further tests

More tests can be conducted with other input attenuators configurations.
The pulse amplitude from the Pulse Generator can be reduced to explore the dynamic range.

ALGORITHM, SENSITIVITY & POLARITY

Orthogonal pickups version

$$X = K_x \text{ Log } A/C$$

$$Y = K_y \text{ Log } B/D$$

Where K_x and K_y are factory-set
 for on-center sensitivity 55.5 mV/dB
 For pickup electrodes with small ϕ ,
 55.5 mV corresponds to 1/36 of radius
 beam displacement.

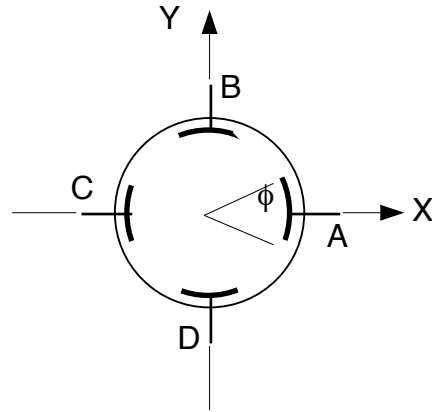

Rotated pickups version

$$X = K_x [\text{Log } (A/C) - \text{Log } (B/D)] \cos \alpha$$

$$Y = K_y [\text{Log } (A/C) + \text{Log } (B/D)] \sin \alpha$$

Where K_x and K_y are factory-set
 for on-center sensitivity 55.5 mV per
 dB of difference between opposite pickups.
 When $\cos \alpha = \sin \alpha = 1/\sqrt{2}$, the sensitivity in X and Y
 equals $55.5\text{mV}/\sqrt{2} = 39.2$ mV.
 For pickup electrodes with small ϕ ,
 39.2 mV in X or Y corresponds to 1/36 of radius
 beam displacement along the X, resp. Y axis.

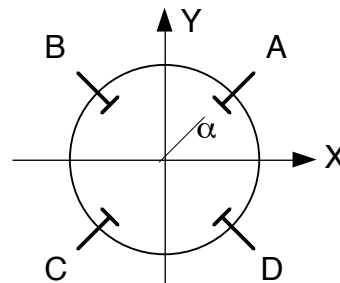

Note:

Pickups with larger ϕ , such as striplines, have higher sensitivity to beam displacement.
 Pickup sensitivity increases with ϕ as $\text{Sin}(\phi/2) / \phi$. [1]

[1] Log-ratio Signal-Processing Technique for Beam Position Monitors, Robert E. Shafer, Proceedings of the Fourth Accelerator Instrumentation Workshop, Berkeley 1992. AIP Conf. proceedings No. 281, pages 120-128.

ON-BOARD ADJUSTMENTS

The BB-BPM module is equipped with many on-board potentiometers. Some can be readjusted easily by the users, while others require precise tools and procedures for their adjustment. The function of each adjustment is described hereafter.

Procedure

Proceed as described in "Quick Check".

The table-top test kit (BPM-KIT) is the easiest setup to readjust potentiometers.

An alternative is to extend the BB-BPM module out of its chassis, using the card extender (BPM-XTD).

Note: No damage will occur to BB-BPM modules if they are inserted or removed while the power is on.

Note: The card extender has unequal button-to-button attenuations. It introduces an offset in X and Y. The card extender offset was measured at the time of shipment. To recheck it, measure the X and Y offsets with and without extender.

To adjust the on-board potentiometers, remove the shield:

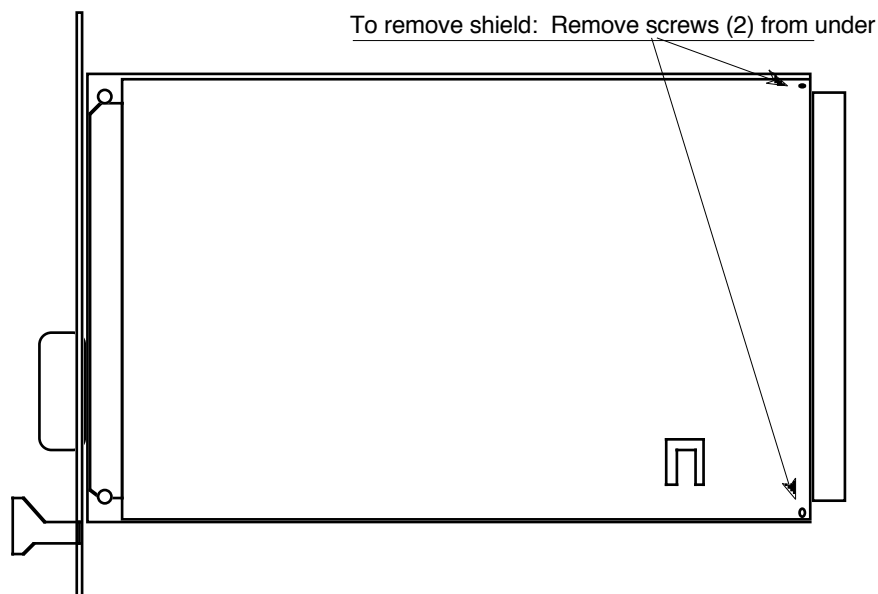

ON-BOARD ADJUSTMENT (Cont'd)

Baseband Beam Position Monitor board

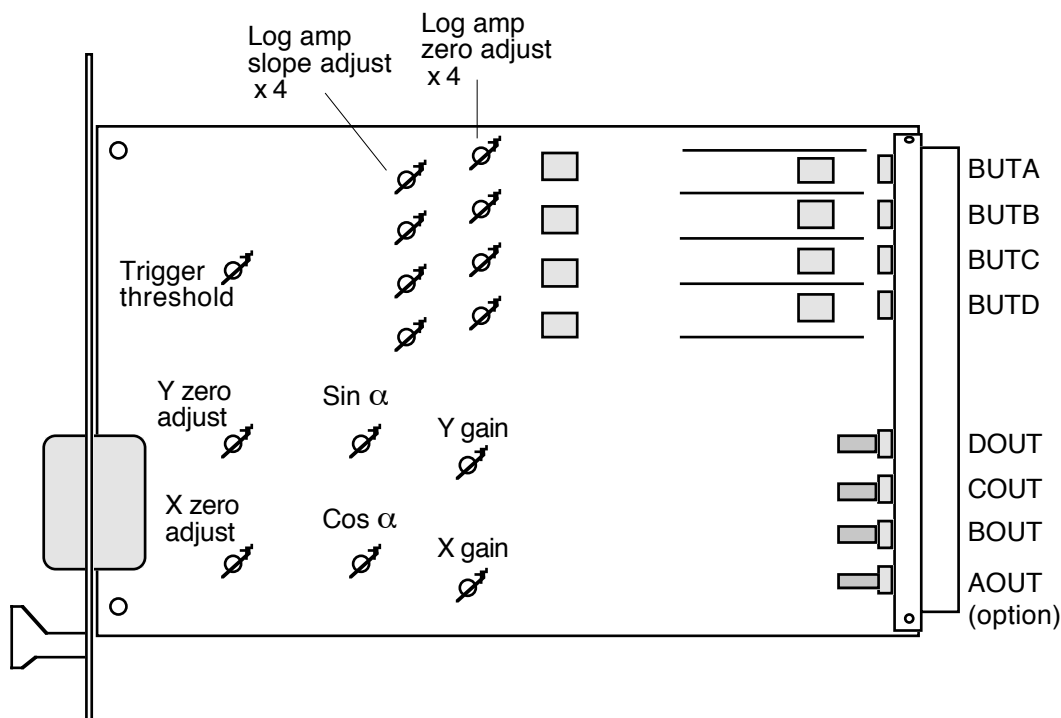

It is not recommended to change the following adjustments:

- Log amplifier zero adjust* To match the origin of two opposite log amplifiers
- Log amplifier slope adjust* To match the slope of all four log amplifiers

Users' adjustments

To adjust these potentiometers, use a screwdriver with a ceramic tip. A metal tip changes the signal !

- Trigger threshold** Sets the trigger level sensitivity (200mV factory-set)
Adjustable up to 500 mV of Sum-of-logs
- Cos α and Sin α** Sets the pickups tilt angle (both are $1/\sqrt{2}$ factory-set)
- X gain & Y gain** Sets the X and Y gains
X and Y gains factory settings:
347mV for 6 dB between opposite orthogonal pickups (1 on 1),
490mV for 6 dB between opposite rotated pickups (2 on 2).
- X zero adjust** Matches the log(A/C) input levels
- Y zero adjust** Matches the log(B/D) input levels

BB-BPM PRINCIPLE OF OPERATION

The signals from the pickup electrodes are processed simultaneously thru four independent channels. Each channel consists of an input band-pass filter, followed by an amplification chain with logarithmic response.

When a single short pulse is applied to the band-pass filter, it will oscillate at its own resonant frequency for about 250 ns, allowing enough time for the logarithmic amplifier to detect the log of its envelope.

Each amplifying chain produces a signal which peak amplitude is proportional to the log of the input signal, be it a single pulse, a pulse train, or a continuous wave.

Log signals from opposite pickup electrodes are deducted from one another to obtain $\text{Log}(A) - \text{Log}(C) = \text{Log}(A/C)$ which is said to be a very faithful representation of beam displacement between two pickup electrodes.

If the pickup electrodes are placed along the axes in which the beam displacement is to be measured, the displacement $X = K_x \text{Log}(A/C)$, directly. The K_x gain is obtained by an amplifier with adjustable gain. The same goes for the Y axis.

If the pickup electrodes are placed along axes rotated as compared to the beam position measurement axes, the A-C and B-D axes must be rotated to obtain the beam displacement values along X and Y. This is achieved by applying the cosine of the tilt angle to one axis and the sine of the tilt angle to the other axis, before summing them. This is done wideband with >10 MHz response.

Schematic representation of the log-ratio BPM, an original concept of Robert E. Shafer:

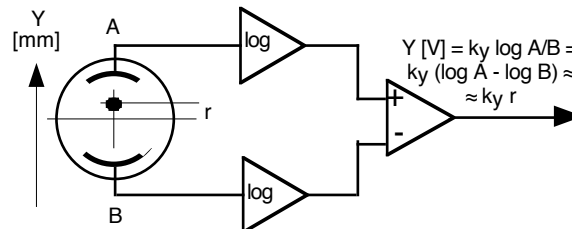

Position measured by this method is more linear, over a wider range, than difference-over-sum.

BLOCK DIAGRAM

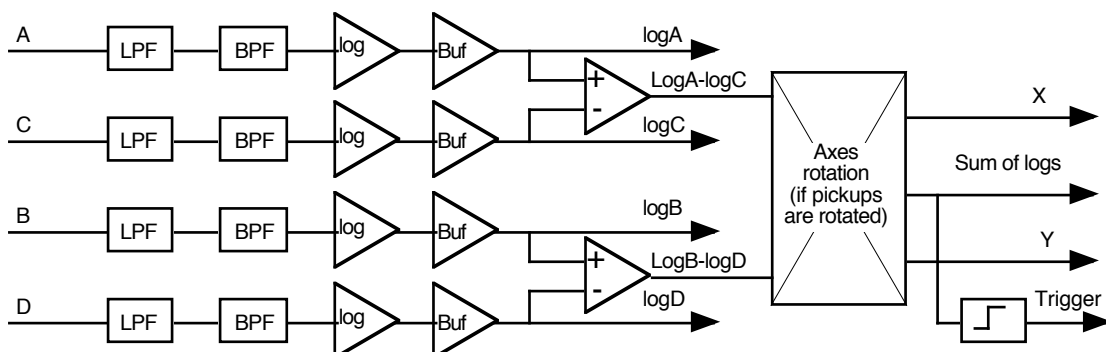

PERFORMANCE

Performance with CW input signals is reported for each module. Plots are attached to the Certificate of Calibration. Example on next page.

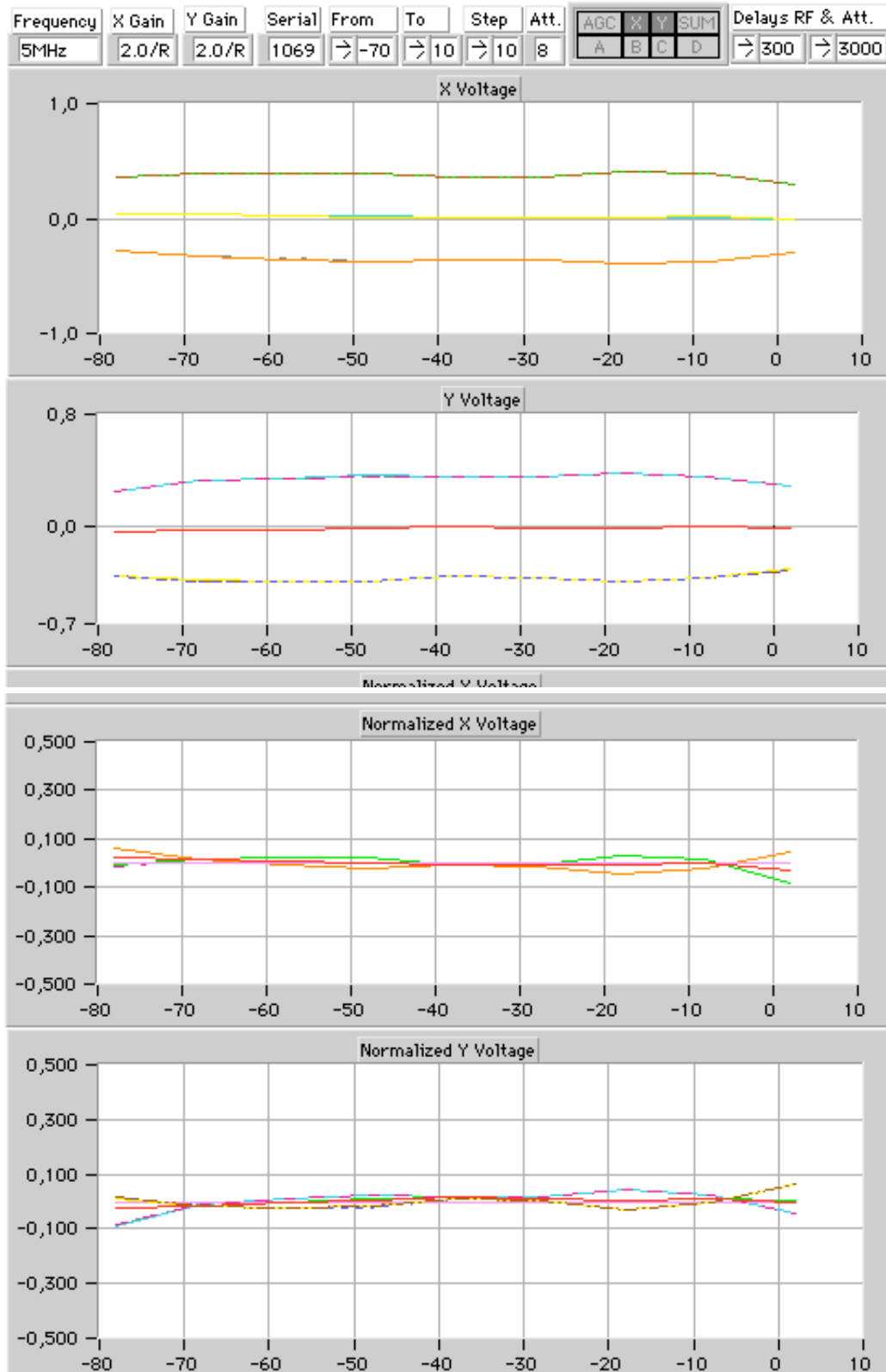

Note: X and Y signal displays are limited to ~1 kHz by the virtual instrument LabVIEW.

SIGNALS

Pickup Inputs

BUTA	Pickup inputs A, B, C, and D. Impedance 50Ω.
BUTB	See Algorithms, Sensitivity & Polarity, this manual, for pickups assignment.
BUTC	
BUTD	

Output narrowband signals (0...200 Hz) High-impedance

XOUT	X displacement. Bipolar signal up to ±2V. 0 Volt represents pickup center.
YOUT	Y displacement. Bipolar signal up to ±2V. 0 Volt represents pickup center.
XYGND	Analog ground for the above signals.

Output wideband signals (0...5 MHz) 50-ohm impedance

XOUT	X displacement. Bipolar signal up to ±2V. 0 Volt represents pickup center.
YOUT	Y displacement. Bipolar signal up to ±2V. 0 Volt represents pickup center.
XYGND	Analog ground for the above signals.

Optional Output wideband signals

Note: These optional signals are made available to compute beam position when the algorithm implemented in the circuit Log(A/C) is unsuitable. This can be the case of 6-button BPM pickups or asymmetric geometry of pickup electrodes.

LOGA	Logarithmic representation of BUTA input.
LOGB	Logarithmic representation of BUTB input.
LOGC	Logarithmic representation of BUTC input.
LOGD	Logarithmic representation of BUTD input.

Input and output signals

Input and output signals hereafter are specific to each BPM module

SUM	Sum of logs (LogA + LogB + LogC + LogD) Equal to log of beam intensity, for centered beam.
GND	Ground for above signal(s).
BT	Beam Trigger. >500-mV positive going pulse with rising edge ~1 us before log signals reach their apex.
BT*	Beam Trigger. >500-mV negative going pulse with falling edge ~1 us before log signals reach their apex.
BTGND	Ground for BT and BT* signals

Common external commands

Common external commands are commands which are common to all BPM modules in a BPM chassis.

None are handled by BB-BPM

BPM CABLES LAYOUT INSTALLATION

Cable layout

Unnecessary intermediate connectors should be avoided. When for practical reasons patch-panels must be used, the cables on either side of the patch-panel should be passed through tubular ferrite cores. Ferrite material must have high permeability at the BPM operating frequency.

The four cables pertaining to the same BPM stations must be laid side by side. Cables, BPM chassis and modules should be kept away –as much as possible– from RF equipment, klystrons, cavities.

Connectors must be chosen carefully to match the cable used. Connectors manufacturers instructions must be followed meticulously. If cable layout is subcontracted, subcontractors must be informed of the extreme reliability expected from these cables. All cables with connectors must be checked before installation with a network analyzer, up to twice the operating frequency at least.

BB-BPM modules must be installed in an RF-shielded chassis.

Note: Unlike most BPM electronics, the BB-BPM module does not require the button signals to be in phase. Cables do not need to be phase-adjusted. The BB-BPM module tolerates any phase change, even 180°.

CONNECTORS PINS ALLOCATION Rev. 3.3

BB-BPM Connectors Pins Allocation				
DB15 female connector on BPM-RFC rear panel (one connector per BPM station)				
DIN41612M BB-BPM module rear connector				
DB9 female connector on BB-BPM front panel				
RF Input signals				
Input A	BUTA		b2 *	
Input B	BUTB		b5 *	
Input C	BUTC		b8 *	
Input D	BUTD		b11 *	
* Coaxial insert 1.0/2.3 type				
Wideband output signals				
X output 0...5 MHz	XOUT	1		
Y output 0...5 MHz	YOUT	3		
Analog ground for X and Y outputs	XYGND	2		
<i>Optional output signals</i>				
Sum of logs	SUM	7	b20	5
Log of A	LOGA		b22 *	
Log of B	LOGB		b25 *	
Log of C	LOGC		b28 *	
Log of D	LOGD		b31 *	
* Coaxial insert 1.0/2.3 type				
Narrowband output signals				
X output 0...200 Hz	XOUT		a15	8
Y output 0...200 Hz	YOUT		a18	7
Analog ground for X and Y outputs	XYGND		a20, a17, a14 b19, a16	4, 6, 9, 13, 15
Single bunch trigger outputs				
Beam Trigger, positive-going	BT		c19, c20	2, 3
Beam Trigger, negative going	BT*	9		
External controls (Reserved)				
Beam-based Center Enable	BBCE	5	a13, b13	1
Ground	GND	4	b14	10
Power supply & Grounds				
+ (8...15) V	+15V		c13	
- (8...15) V	-15V		c15	
Common	COM		c14	
Ground	GND	6	a19, b18	

ACCESSORIES

Table-top test kit (BPM-KIT)

Old versions may be equipped with a single AC mains voltage power supply, e.g 100 Vac in Japan. ***Please check AC mains voltage before using old BPM-KIT.***
New BPM-KITs are all equipped with autoranging power supplies 98...265 Vac.

The BPM-KIT versions 1 and 2 were specially made to test Multiplexed BPMs (MX-BPM) They can be used with BB-BPM, but their BNC connectors labelled X, Y, AGC, SYNC and SUM do not give the expected signals X, Y, AGC, SYNC and SUM.

New BPM-KIT versions are in preparation. In the meantime, old BPM-KITs are patched for operation with BB-BPM and LR-BPM.

BPM-KIT features an 8-bit DIP switch. All switches should be OFF for proper BB-BPM operation.

The BPM-KIT is very convenient. It allows the BB-BPM module to be placed flat on the table. In this position, the shield can be removed, and the user can re-adjust the BB-BPM settings. See paragraph ON-BOARD ADJUSTMENTS, this manual.

These adjustments above cannot be made when the BB-BPM processing unit is in the chassis. They require a BPM-KIT or a card extender BPM-XTD.

Extender BPM-XTD

The card extender allows access to the BPM module adjustments while it is connected to the chassis, thus to the readout and control system.

The BPM-XTD is not as convenient as the BPM-KIT for adjustments.

The coaxial connections extensions of the button signals cause an offset of the X and Y outputs when the extender is used. This is due to the difference in signal attenuation between the 4 extension cables. These differences are recorded on a label affixed to the extender.

RF Service module BPM-SERV/RF

The RF Service module can be inserted in a BPM station of a chassis, in place of the BPM module.

It brings to the front panel –on BNC jacks– the four signals applied to this BPM station by the BPM buttons.

For oscilloscope and spectrum analyser viewing of the BPM button signals.

Very useful, because the RF cables at the rear of the chassis are too crowded to be disconnected.

ACCESSORIES (Cont'd)

BPM Chassis, can house any mix of MX-BPM, LR-BPM and BB-BPM

BPM-RFC/X chassis is built around a 19" Schroff rackable RF chassis.

Dimensions of the bin: 3U x 84F

Schroff reference: Europac Lab HF/RF #20845-283

The BPM-RFC/X is available equipped for 1 up to 16 BPM stations. X being the number of stations.

BPM-RFC/X with less than 16 stations are partially equipped BPM-RFC/16. As a result, all BPM chassis are field-upgradable to the full 16-station chassis.

Chassis rear view

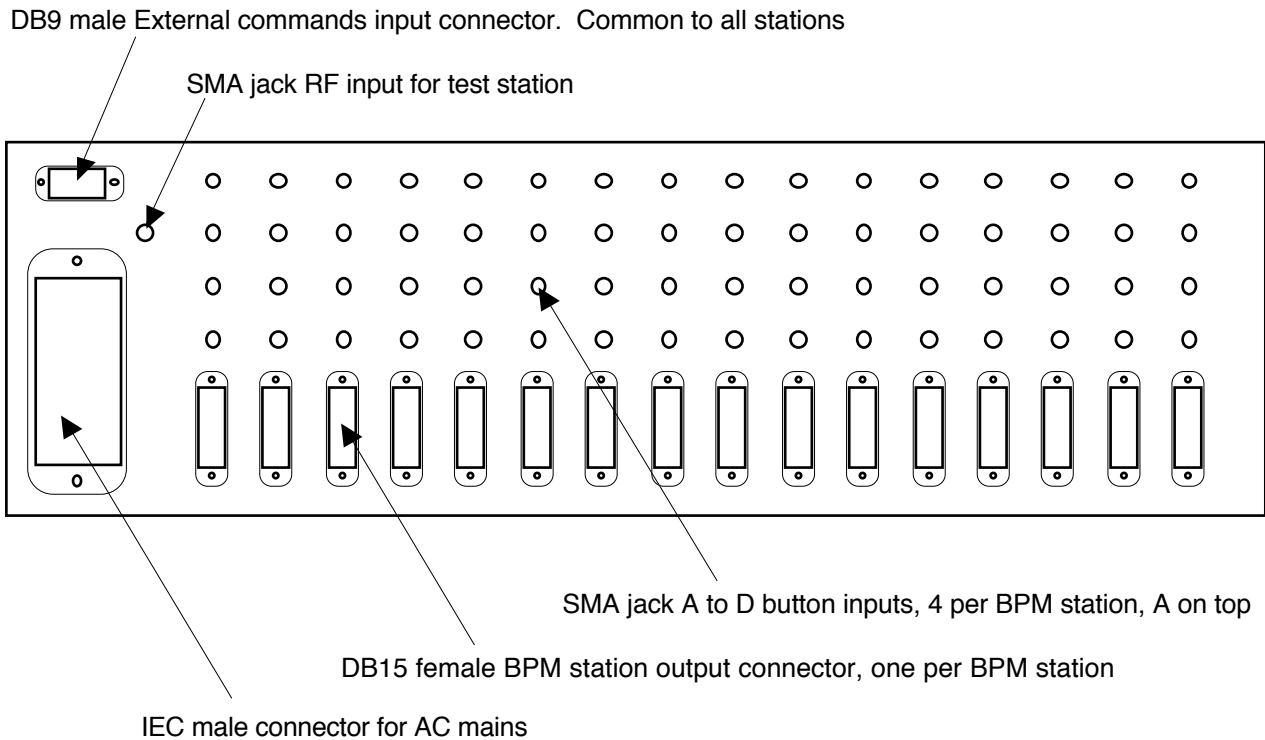

SPECIFICATIONS

Power Supply module

AC mains voltage	Autoranging 98...132Vac and 185...265Vac with automatic range changeover
Power derating	No derating down to 85 Vac (at full chassis load)
Output	± 15 V, unequal loading tolerant
Power	75 W
Efficiency	84% at 220Vac 81% at 110 Vac
Inrush current	limited to 10A max.
Dimensions	per DIN41494: 3U high, 8F wide, 160mm deep
Manufacturer	Delta Elektronika BV, the Netherlands
Model	75 SX 15-15

BPM MODULE REAR CONNECTOR DIN41612M 24+8

Note: For connections, See Connector Pins Allocation, this manual.

BPM chassis for 1 up to 16 BPM modules are part of Bergoz Instrumentation sales program (BPM-RFC/X) and include the necessary mating connectors (See BPM chassis, this manual). The following is of interest to those who wish to design their own chassis.

The BPM module rear connector commonly designated DIN41612M 24+8 is a male connector with 24 pin contacts and 8 holes for coaxial connectors. V42254-B1200-M240 from Siemens is the reference used.

The coaxial connectors inserted in the rear connector are of the “jack”-type series 1.0/2.3. Four V23601-A1227-E1 from Siemens are used for button inputs (jack, right angle, soldering type)

One V23601-A602-E71 from Siemens is used for the optional Fast Gate (jack, straight, crimp)

On the chassis side (or “Backplane” side), for each BPM module, the following is needed:

- One DIN41612M female connector with 24 pin contacts and 8 holes for coaxial connectors. We recommend using Siemens connectors to assure compatibility:
V42254-B2240-M240 from Siemens, for wrapping connection
V42254-B2202-M240 from Siemens, for soldering connection (4.5-mm pins)
Other references available for press-fit connection.
- Four or five coaxial “plug”-type connectors, series 1.0/2.3. A large number of manufacturers produce these connectors. However, to assure good connector mating, we recommend that you use connectors from Siemens:
V23601-B302-E71 or V23601-A302-E71 for straight cable attachment to RG316 ($\text{\O ext.} \leq 2.6\text{mm}$)
V23601-A302-E1 for straight cable attachment to RG178 ($\text{\O ext.} \leq 1.9\text{mm}$)
V23601-A502-E71 (18.7mm long) for 90° angle cable attachment to RG316 ($\text{\O ext.} \leq 2.6\text{mm}$)
V23601-A556-E71 (22.3mm long) for 90° angle cable attachment to RG316 ($\text{\O ext.} \leq 2.6\text{mm}$)
V23601-A502-E73 (18.7mm long) for 90° angle cable attachment to RD316 ($\text{\O ext.} \leq 3.0\text{mm}$)
V23601-A556-E73 (22.3mm long) for 90° angle cable attachment to RD316 ($\text{\O ext.} \leq 3.0\text{mm}$)

Cable type correspondence:

US manufacturers' designation	VDE designation	IEC designation
RG316	5YC5Ye 0,5/1,5	50-2-1
RD316	5YCC5Y 0,5/1,5	--
RG178	5YC5Ye 0,3/0,86	50-1-1

Siemens recommends to use connector crimping tool reference M1002-K1.

SCHEMATICS & BOARD LAYOUT

Schematics and board layouts of our instruments remain the exclusive property of Bergoz Instrumentation at all times. They are protected by the copyright laws.

Schematics and board layouts are not delivered with our instruments. They can be obtained at the specific request of the instrument's user.

A request should be sent by fax, worded in the following way:

To: Bergoz Instrumentation

From: *User's name*

Date:.....

I am a user of instrument type xxx-xxx serial nr. xxx,xxx,xxx,xxx, etc.

Please send me one copy of the corresponding schematics and board layout.

I will use it for the instrument's maintenance only.

I will make copies only for my own use.

I will inform others who need these schematics that they should request them from Bergoz Instrumentation.

Signed:

ACKNOWLEDGEMENT

Baseband BPM are based on the Log-ratio principle. The fundamental principles of Log-ratio BPM modules were developed by Robert E. Shafer while at Los Alamos National Laboratory. We sincerely thank him for his considerable contribution.

Our BB-BPM module was developed by Alexandre Kalinine. Earlier work was performed by Klaus Unser and Jim Hinkson, which contributed to Kalinine's design.

Saint Genis Pouilly,
Revised June 2003 (baseband, narrowband options)
Revised Sept., Oct. and Nov. 2007